

Pass your CDL!



Visit now!

# CALIFORNIA Commercial DRIVER HANDBOOK 2008



**Arnold Schwarzenegger**, *Governor*  
State of California

**Dale E. Bonner**, *Secretary*  
Business, Transportation and Housing Agency

**George Valverde**, *Director*  
Department of Motor Vehicles

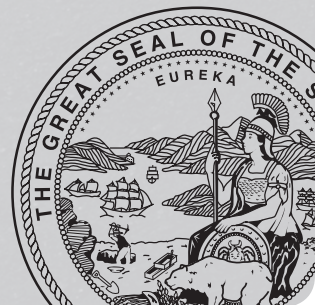

Pass your CDL!



**CDLPass.com**

Visit now!

**CALIFORNIA DRIVER LICENSE CLASSES—Valid As Of January 1, 2008**

YOU MAY DRIVE...	AND YOU MAY TOW...	EXAMPLES...
<p><b>WITH A COMMERCIAL CLASS A LICENSE:</b> Any legal combination of vehicles, including vehicles under Class B and Class C</p>	<ul style="list-style-type: none"> <li>any single vehicle with a Gross Vehicle Weight Rating (GVWR) of more than 10,000 lbs.</li> <li>any trailer bus, with endorsement <b>OR</b> more than one vehicle, with endorsement</li> <li>any vehicles under Classes B and C</li> </ul>	
<p><b>WITH A RESTRICTED CLASS A FIRE FIGHTER LICENSE:</b> Only Class A and Class B defined combination fire fighting vehicles and all vehicles listed under Class C.</p>	<ul style="list-style-type: none"> <li>a single fire fighting vehicle with a GVWR of more than 10,000 lbs.</li> <li>any fire fighting vehicle under Class B <b>or</b> any vehicle under Class C</li> <li>more than one fire fighting vehicle, with endorsement</li> </ul>	
<p><b>WITH A NONCOMMERCIAL CLASS A LICENSE:</b> Any vehicles under Class C.</p>	<ul style="list-style-type: none"> <li>travel trailers weighing over 10,000 lbs. GVWR, not used for hire.</li> <li>5th-wheel travel trailers weighing over 15,000 lbs., not used for hire.</li> </ul> <p><i>With a vehicle weighing 4,000 lbs. or more unladen, you may tow a:</i> livestock trailer exceeding 10,000 lbs. GVWR but not exceeding 15,000 lbs. GVWR if the vehicle is controlled and operated by a farmer, used to transport livestock to or from a farm, not used in commerce or contract carrier operations, and is used within 150 miles of the person's farm.</p>	
<p><b>WITH A COMMERCIAL CLASS B LICENSE:</b> • a single vehicle with a GVWR of more than 26,000 lbs. • a 3-axle vehicle weighing over 6,000 lbs. • a bus (except a trailer bus), with endorsement • any farm labor vehicle, with endorsement • all vehicles under Class C</p>	<ul style="list-style-type: none"> <li>a single vehicle with a GVWR of 10,000 lbs. or less</li> <li>any vehicle a Class C licensed driver may tow</li> </ul>	
<p><b>WITH A RESTRICTED CLASS B FIRE FIGHTER LICENSE:</b> Only a Class B defined single fire fighting vehicle and all the vehicles listed under Class C.</p>	<ul style="list-style-type: none"> <li>a single vehicle with a GVWR of 10,000 lbs. or less including a tow dolly, if used.</li> </ul> <p><i>With a vehicle weighing 4,000 lbs. or more unladen, you may tow a:</i></p> <ul style="list-style-type: none"> <li>trailer coach not exceeding 9,000 lbs. gross.</li> <li>trailer coach or 5th-wheel travel trailer under 10,000 lbs. GVWR when towing is not for compensation</li> <li>5th-wheel travel trailer exceeding 10,000 lbs. but not exceeding 15,000 lbs. GVWR, when towing is not for compensation and with endorsement.</li> </ul> <p><b>NOTE:</b> No passenger vehicle regardless of weight, may tow more than one vehicle. No motor vehicle under 4,000 lbs. unladen may tow any vehicle weighing 6,000 lbs. or more gross. (VC §21715)</p>	
<p><b>WITH A NONCOMMERCIAL CLASS B LICENSE:</b> • any vehicles under Class C • any housecar over 40' but not over 45', with endorsement</p>	<ul style="list-style-type: none"> <li>a single vehicle with a GVWR of 10,000 lbs. or less</li> <li>any vehicle a Class C licensed driver may tow</li> </ul>	
<p><b>WITH A BASIC CLASS C LICENSE:</b> • a 2-axle vehicle with a GVWR of 26,000 lbs. or less • a 3-axle vehicle weighing 6,000 lbs. gross or less • a motorized scooter • any housecar 40' or less <i>A farmer or employee of a farmer may also drive:</i></p> <ul style="list-style-type: none"> <li>any combination of vehicles with a Gross Combination Weight Rating (GCWR) of 26,000 lbs. or less if used exclusively in agricultural operations <b>and</b> it is not for hire or compensation.</li> </ul>	<ul style="list-style-type: none"> <li>a single vehicle with a GVWR of 10,000 lbs. or less</li> <li>any vehicle a Class C licensed driver may tow</li> </ul>	
<p><b>WITH A COMMERCIAL CLASS C LICENSE:</b> Any Class C vehicle carrying hazardous materials which requires placards. The hazardous materials (HAZMAT) endorsement must be on the license. Drivers who transport hazardous wastes, as defined by VC §§353 and 15278, are also required to have the HAZMAT endorsement.</p>	<ul style="list-style-type: none"> <li>a single vehicle with a GVWR of 10,000 lbs. or less</li> <li>any vehicle a Class C licensed driver may tow</li> </ul>	
<p><b>WITH A MOTORCYCLE CLASS M1 LICENSE:</b> Two-wheel motorcycle, motor-driven cycle, or motorized scooter.</p>	<ul style="list-style-type: none"> <li>a single vehicle with a GVWR of 10,000 lbs. or less</li> <li>any vehicle a Class C licensed driver may tow</li> </ul>	
<p><b>WITH A MOTORCYCLE CLASS M2 LICENSE:</b> Motorized bicycle, moped, any bicycle with an attached motor, or motorized scooter.</p>	<ul style="list-style-type: none"> <li>a single vehicle with a GVWR of 10,000 lbs. or less</li> <li>any vehicle a Class C licensed driver may tow</li> </ul>	

## New Cellular Phone Laws Go Into Effect July 1, 2008

<b>Minors (under 18 years of age)</b> VC §23124	<b>Drivers 18 years of age or older</b> VC §23123
<p><b>Are prohibited</b> from driving a motor vehicle while using a wireless telephone, including a hands-free device, and/or a mobile service device (pagers, texting devices, laptops, etc).</p>	<p><b>Are prohibited</b> from driving a motor vehicle while using a wireless telephone unless a hands-free device is used.</p>
<p><b>Exceptions:</b></p> <ul style="list-style-type: none"> <li>• Emergency situations, for example: calls to law enforcement, health care provider, fire department, etc.</li> <li>• While operating a vehicle on private property.</li> </ul>	<p><b>Exceptions:</b></p> <ul style="list-style-type: none"> <li>• Emergency situations, for example: calls to law enforcement, health care provider, fire department, etc.</li> <li>• Emergency service providers operating an authorized emergency vehicle during the course of employment.</li> <li>• While operating a vehicle on private property.</li> <li>• A person operating a commercial motor truck or truck tractor (excluding pickups), implements of husbandry, farm vehicle, school bus, transit vehicle, or tow truck, if using a two-way radio operated by a “push-to-talk” feature that does not require the device to be close to the ear.</li> </ul>
<p>The fines for both laws are:</p> <ul style="list-style-type: none"> <li>• \$20, first offense plus administrative fees.</li> <li>• \$50, second or subsequent offenses plus administrative fees.</li> </ul>	

# Table of Contents

<b>Section 1. Introduction .....1</b> <b>(For all commercial drivers)</b>	<b>Section 4. Transporting Passengers.....57</b> <b>(For a passenger transport endorsement)</b>
Who needs a CDL?..... 1	Vehicle Inspections.....57
CDL Exceptions .....2	Loading and Unloading .....59
How to Get a CDL.....3	Driving Techniques .....60
Additional Requirements.....7	Passenger Management .....61
State Laws and Rules.....8	Miscellaneous Requirements.....61
Other Rules..... 13	
<b>Section 2. Driving Safely .....19</b> <b>(For all commercial drivers)</b>	<b>Section 5. Air Brakes .....63</b> <b>(If you drive combination vehicles or tow vehicles with air brakes)</b>
Vehicle Inspections..... 19	The Air Brake System .....63
Basic Vehicle Control.....22	Dual Air Brake Systems .....67
Shifting Gears .....23	Combination Vehicle Air Brakes .....68
Seeing .....24	Inspecting the Air Brake System.....70
Communicating .....26	Using Air Brakes .....73
Controlling Speed .....28	
Managing Space .....31	<b>Section 6. Combination Vehicles .....75</b> <b>(For a Class A CDL)</b>
Driving at Night.....33	Driving Combination Vehicles
Driving in Fog .....35	Safely .....75
Driving in Winter.....35	Coupling and Uncoupling.....77
Driving in Very Hot Weather .....37	Inspecting a Combination Vehicle .....80
Mountain Driving .....38	
Railroad Crossings.....39	<b>Section 7. Doubles and Triples .....81</b> <b>(For double or triple trailers)</b>
Seeing Hazards .....40	Towing Double/Triple Trailers.....81
Emergencies.....42	Coupling and Uncoupling.....81
Skid Control and Recovery.....45	Inspecting Doubles and Triples .....83
Accident Procedures .....46	Doubles/Triples Air Brake Check .....84
Fires .....47	
Staying Alert and Fit to Drive .....48	<b>Section 8. Tank Vehicles .....85</b> <b>(For tank vehicles)</b>
HazMat Rules for all Commercial Drivers .....51	Tank Vehicle Defined.....85
<b>Section 3. Transporting Cargo Safely .....53</b> <b>(For all commercial drivers)</b>	Inspecting Tank Vehicles .....85
Inspecting Cargo..... 53	Driving Tank Vehicles.....86
Cargo Weight and Balance .....53	Safe Driving Rules.....87
Securing Cargo .....54	
Handling Other Cargo .....55	

<b>Section 9. Hazardous Materials/Wastes .....89</b> (For hazardous materials/wastes requiring placards)	<b>Section 11. Skills Tests .....127</b> (Assists drivers taking the skills test)
Intent of the Regulations.....90	Scoring..... 127
Transporting Hazardous	Exercises..... 127
Materials .....90	
Communication Rules .....91	<b>Section 12. Driving Test .....129</b> (Assists drivers taking the driving test)
Loading and Unloading .....98	How You Will Be Tested ..... 129
Bulk Tanks..... 101	
Federal Driving and Parking	
Rules .....103	<b>Glossary .....133</b>
Dealing with Emergencies.....106	<b>Disclaimer .....135</b>
Appendix A—Table of Hazard Class	<b>Where To Write .....135</b>
Definitions ..... 110	
Hazardous Materials Warning Labels	
and Placards..... 112	
<b>Section 10. Pre-Trip Test .....115</b> (Assists drivers taking the pre-trip test)	
All Vehicles ..... 115	
External Inspection	
(School Bus/Truck/Tractor)..... 117	
School Bus Only .....121	
Trailer .....122	
Coach/Transit Bus .....122	
Truck or Combination Vehicle	
Inspection Guide..... 125	
Passenger Transport Vehicle	
Inspection Guide..... 126	

---

© Copyright, Department of Motor Vehicles 2008.

All rights reserved.

This work is protected by U.S. copyright Law. DMV owns the copyright of this work. Copyright law prohibits the following: (1) reproduction of the copyrighted work; (2) distribution of copies of the copyrighted work; (3) preparation of derivative works based upon the copyrighted work; (4) displaying the copyrighted work publicly; or (5) performing the copyrighted work publicly. All requests for permission to make copies of all or any part of this publication should be addressed to:

Department of Motor Vehicles  
 Legal Office  
 PO Box 932382  
 Sacramento, CA 94232-3820

# Section 1: Introduction

This section is for all commercial drivers

The California Commercial Motor Vehicle Safety Program was enacted to improve traffic safety on our roadways. As a result, California has developed licensing and testing requirements for drivers of commercial vehicles which equals or exceeds federal standards.

It takes special skills and a professional attitude to safely operate large trucks and buses. Only professional drivers will receive and keep a Commercial Driver License (CDL). A CDL is proof of your professional skills and aptitude.

## Who Needs A CDL?

To operate commercial vehicles, you must apply for a CDL. Only California residents may obtain a California CDL. Residency is established by any of the following: registering to vote here, paying resident tuition at a public institution of higher education, filing for a California homeowner's property tax exemption, obtaining a license (such as a fishing license), or any other privilege or benefit not ordinarily extended to nonresidents. You need a CDL if you operate a vehicle or combination of vehicles which requires a Class A or Class B license or Class C license with endorsements.

A commercial motor vehicle is a motor vehicle or combination of vehicles designed or used for either the transportation of persons for compensation or property and:

- Has a gross vehicle weight rating (GVWR) of 26,001 pounds or more.
- Tows any vehicle with a GVWR of 10,001 pounds or more.
- Tows more than one vehicle or a trailer bus.
- Has three or more axles (excludes three axle vehicles weighing 6,000 pounds or less gross).

- Is any vehicle (bus, farm labor vehicle, general public paratransit vehicle, etc.) designed, used, or maintained to carry more than 10 passengers including the driver, for hire or profit, or is used by any nonprofit organization or group.
- Transports hazardous materials requiring placarding.\*
- Transports hazardous wastes (Health and Safety Code §§25115 and 25117).\*

**NOTE:** Employees of school districts, private schools, community colleges, and California state universities who operate 15-passenger vans must have a CDL with a passenger transport vehicle (PV) endorsement. A 15-passenger van is a van manufactured to accommodate 15 passengers, including the driver, **or** a van “designed” to carry 15 passengers, including the driver, even if seats have been removed to accommodate fewer than 15 passengers.

## Endorsements

A special endorsement is also required to drive the following types of vehicles. The endorsement shows as a single letter on the driver license.

- Placarded or marked vehicles transporting hazardous materials or wastes—H.
- Tank vehicles (including a cement truck)—N.
- Passenger transport vehicles—P.
- School bus—S.
- Double trailer combination—T.
- Tank vehicles transporting hazardous materials or wastes—X. (Hazardous waste must meet the definition of VC §§353 and 15278.)

\* Drivers subject to the commercial driver sanctions.

## CDL Exceptions

Exceptions to the CDL requirements are:

- Persons exempted under Health and Safety Code §25163.
- Persons operating a vehicle in an emergency situation at the direction of a peace officer.
- Drivers who tow a fifth-wheel travel trailer over 15,000 pounds GVWR or a trailer coach over 10,000 pounds GVWR, when the towing is not for compensation. Drivers must have a noncommercial Class A license.
- Drivers of housecars over 40 feet but not over 45 feet, with endorsement.
- Drivers of only fire fighting vehicles or buses used to travel to and from the scene of any emergency situation. Drivers need either a Class A or B license with a fire fighter restriction. A fire fighter may add a “P” endorsement if the bus is owned by a federal or state agency, a city or county fire department, or a volunteer fire department and when the driving is restricted to operating buses as defined in VC §15250.6(g). All fire fighters, whether they have a CDL or a Class A or B fire fighter-restricted driver license, are subject to commercial driver sanctions.
- A fire fighter with a restricted license who transports compressed air tanks for breathing apparatuses that do not exceed 2,500 pounds.
- Noncivilian military personnel operating military vehicles.
- Implement of husbandry operators who are not required to have a driver license.

### Special Certificates

Special certificates may sometimes be required in addition to a CDL, depending on the type of vehicle or load you carry.

**NOTE:** It is unlawful to drive a school bus or transit vehicle while using a wireless (cell) telephone for non-work purposes. Emergency calls to law enforcement, a health care provider,

a fire department, or other emergency services are permitted.

### Apply at DMV field offices for the following certificates:

**Ambulance Driver Certificate**—required for driving an ambulance used commercially in emergency service (VC §2512). Persons who have an ambulance driver certificate must submit a copy of the medical report to DMV every two years. (See page 3.)

**Hazardous Agricultural Materials (HAM)\***—**exempts** persons who transport hazardous waste or placarded loads from CDL requirements if the:

- Person is at least 21 years of age.
- Person is employed in an agricultural operation.
- Load is not being transported for compensation.
- Vehicle is owned or leased by a farmer.
- Person has completed a HAM program approved by the California Highway Patrol (CHP). Although the person who qualifies for a HAM is not required to have a CDL, commercial motor vehicle penalties and sanctions will apply.
- Person submits to DMV every two years a copy of the medical report or health questionnaire.
- Person operates a vehicle which is an implement of husbandry **OR** requires a Class C license and does not exceed 50 miles from one point to another.

**Verification of Transit Training Document (VTT)**—requires drivers of transit bus vehicles to comply with specified training requirements. Transit bus vehicles provide the public with regularly scheduled transportation for which a fare is charged. (Does not include general public paratransit vehicle). Drivers who have a *school bus certificate* or *school pupil activity bus certificate* do not need a VTT.

\* Drivers subject to the commercial driver sanctions.



**Apply at CHP offices for the following certificates:**

**General Public Paratransit Vehicle Certificate (GPPV)\***—required for any person who drives:

- A vehicle which carries not more than 24 persons including the driver and provides local transportation to the general public (e.g., Dial-A-Ride). (VC §§336 and 12523.5)
- Pupils at or below the 12th grade level to or from a public or private school or school activity.

**School Bus Driver Certificate\***—required of any person who drives a bus for any school district or any other party carrying public or private pupils (VC §§545, 12517, 12522, 34500, 34501.5). A school bus driver must also have a school bus (S) endorsement on his/her CDL. School bus drivers 65 years of age and older must submit an annual medical report to DMV. (VC §12517.2)

**School Pupil Activity Bus Certificate (SPAB)\***—required of any person who drives a bus for any school district or any other party carrying public or private pupils for school related activities. (VC §§546 and 12517)

**Farm Labor Vehicle Certificate\***—required to drive farm labor trucks and buses (VC §§322 and 12519). **NOTE:** The driver and all passengers in a farm labor vehicle are required to use seat belts.

**Youth Bus Certificate\***—required to operate any bus other than a school bus which carries not more than 16 children and the driver to or from a school, to an organized non-school related activity, or to and from home (after receiving additional CHP training). (VC §§680 and 12523)

**Tow Truck Driver Certificate\***—required for drivers in emergency road service organizations that provide freeway service patrol operations

pursuant to an agreement or who contract with a specified public transportation planning entity (traffic commission).

**Vehicle for Developmentally Disabled Persons (VDDP)\***—required to operate a vehicle for a business or nonprofit organization or agency whose primary job is to transport for hire persons with developmental disabilities. (Welfare and Institutions Code §4512[A] and VC §12523.6)

## How To Get A CDL

Apply at any DMV field office for a CDL. You:

- May drive for hire within California if you are 18 years of age or older and do not engage in interstate commerce activities.
- Must be at least 21 years old to drive a commercial vehicle engaged in interstate commerce or to transport hazardous materials or wastes (intrastate or interstate commerce). (VC §12515)

### Provide The Following Items:

- A completed Commercial Driver License Application (DL 44C) form. Signing this form means you agree to submit to a chemical test to determine the alcohol or drug content of your blood. If you refuse to sign this form, DMV will not issue or renew your driver license.
- Your true full name.
- An approved medical form (or copy) completed by a U.S. licensed doctor of medicine (M.D.), licensed doctor of osteopathy (D.O.), licensed physician's assistant (P.A.), nurse practitioner (N.P.), registered advanced practice nurse (APN), or licensed chiropractor when you apply for a driver license or instruction permit. Drivers who hold certificates to drive school buses, SPAB, youth buses, GPPV, or farm labor vehicles must have their medical examinations given by doctors of

\* Drivers subject to the commercial driver sanctions.

**Fees subject to legislative change each January 1st.**

If the class of license is...	and the application type is... the fee is...
Commercial Class A or B	an original—no prior California DL (with/without a driving test).....\$64 an original—prior California DL (with/without a driving test).....\$64 to remove a restriction(s) imposed due to vehicle size or equipment.....\$64 to add a passenger transport endorsement .....\$64 a driving or skill retest fee .....\$30 a renewal .....\$34 a renewal by mail .....\$39 add an endorsement other than PV .....\$34 add noncommercial Class A to a Class B .....\$34 add Class M1/M2.....\$34 a duplicate .....\$27 a name change.....\$22 a duplicate .....\$27
Fire fighters restricted Class A or B	an original—prior California DL .....\$34 a renewal .....\$34 a renewal by mail.....\$39 remove a restriction imposed due to vehicle size or equipment .....\$34 an endorsement requiring a driving test.....\$34 a name change.....\$22 an original—no prior California DL (with/without a driving test).....\$34
Commercial Class C	an original—prior California DL (with/without a driving test).....\$34 a renewal .....\$34 a renewal by mail.....\$39 add an endorsement not requiring a driving test.....\$34 remove an air brake restriction .....\$34 a duplicate .....\$27 a driving or skill retest fee .....\$30 a name change.....\$22

medicine, licensed physician’s assistant, or a registered advanced practice nurse. (VC §12517.2)

and then every two years after that. Mail the interim medical to:

**NOTE:** Do **not** mail your medical report to the CHP.  
 A medical report dated within the last two years is required for any CDL application

Department of Motor Vehicles  
 Commercial Problem Drivers Inquiry Unit  
 MS G204  
 PO Box 942890  
 Sacramento, CA 94290-0001

## CDL Offices

Call 1-800-777-0133 to schedule a CDL driving test in one of the following offices:

Arleta	Fremont	Salinas	Torrance
Bakersfield	Fresno	San Bernardino CDL Driving Test Center	Ukiah
Bishop	Fullerton	San Luis Obispo	Vallejo
Capitola	Hemet	Santa Barbara	Ventura
Compton	Lancaster	Santa Maria	Visalia
Culver City	Modesto	Santa Rosa	W Sacramento CDL Driving Test Center
El Centro	Montebello	Santa Teresa	Yuba City
Escondido CDL Driving Test Center	Oakland-Coliseum	Spring Valley	
Eureka	Redding	Stockton	

You will be given a Medical Certificate Card (DL51A) to carry when you drive commercially. You can be given a citation for driving out of class if your medical certificate expires or you drive without a valid medical certificate in your possession. You may also be removed from your vehicle by a law enforcement officer for driving out of class.

If you must have a CDL as part of your job, your employer shall pay the cost of the examination unless your examination was taken before you applied for the job (Labor Code §231).

**NOTE:** Customers who do not meet the minimum medical standards, will either be restricted or refused a CDL. The restrictions are:

- may not transport passengers commercially or transport materials which require placards. (VC §27903)
- may not drive in interstate commerce.
- An acceptable birth date/legal presence (BD/LP) document. All applicants for an original DL/ID card must submit proof of legal presence in the US as authorized under federal law. If the name on your BD/LP document is different from the name on your DL application form, you must

also bring in an acceptable true full name document. Your true full name, as shown on your BD/LP document, will appear on your DL/ID card. (Refer to the *California Driver Handbook*.)

An acceptable BD/LP or true full name document is one produced by an issuing authority (i.e., county, state, etc.). This document is a certified copy of the original (the original is always retained by the issuing authority) and will contain an impressed seal or an original stamped impression. The certified copy will be returned to you. If you make a copy of the certified copy, DMV will **not** accept it for BD/LP verification.

- Your Social Security Card (cannot be laminated), Medicare card, or U.S. Armed Forces active, retired, or reserve DD2 form for an original CDL. The document must contain your name and SSN. Your SSN will be verified with the Social Security Administration while you are in the office.
- A Certificate of Driving Skill (DL 170) or Firefighter Certificate of Skill (DL 170 F ETP) if your employer is authorized by DMV to issue such certificates. Both you and your employer sign this form.

- The applicable fee. This fee is good for 12 months from the application date. You are allowed three attempts to pass the written knowledge test and a total of three attempts to pass the entire road test (pre-trip inspection, skills, and driving test) on a single application. If you fail any portion of the road test (pre-trip inspection, skills, or driving test), it will count as one failure towards the maximum three attempts you are allowed. Example: Failing the pre-trip inspection, skills test, and driving test counts as a three-time failure (or any failure combination equaling three). However, if you are required to take a driving test for separate types of vehicles (Class A or passenger transport vehicle), you are allowed three *driving* tests for the Class A vehicle and three *driving* tests for the passenger transport vehicle.

## Required Testing

You must take and pass vision, knowledge (law), and performance (pre-trip and driving, if required) tests to get your original CDL and/or endorsements or to upgrade to a different class of license. Law and vision tests may be required for renewals. A driving test is required:

- For an original CDL.
- To remove a restriction placed on your license because of vehicle size or equipment.
- To add a “P” or “S” endorsement.
- To renew a CDL expired for more than two years.

The CDL law tests are:

- General Knowledge Test, for all Class A and B applicants.
- Air Brakes Test, if you operate vehicles with air brakes.
- Combination Vehicles Test, if you drive Class A combination vehicles.
- Passenger Transport Vehicle Test, if you transport passengers.
- Hazardous Materials Test, if you transport

hazardous materials or wastes requiring placards.

- Tank Vehicle Test, if you transport liquids in bulk (including cement mixers).
- Doubles/Triples Test, if you pull double or triple trailers. (Triple trailers are illegal in California.)

**NOTE:** Your law and/or endorsement test(s) will **not** be returned to you.

After passing the required knowledge test(s), you will take the CDL performance tests which include a pre-trip inspection/knowledge test, basic control skills tests, and the driving test. You must use the same (or similar) vehicle for all three performance tests. Under certain specified conditions, the driving test requirements may be waived by DMV or CHP.

**Pre-trip inspection.** You demonstrate your knowledge of how the specific features and equipment on the test vehicle should be checked. This handbook contains inspection guides on pages 125 and 126 for handy reference. **You may use only one of these guides when taking your pre-trip test.** If you do not pass the pre-trip inspection test, the other tests will be postponed. There is no additional fee for repeat pre-trip tests on the same application. *See Section 10 for pre trip information.*

**Skills tests.** You perform various skills that test your control and ability to maneuver the vehicle. The tests consist of exercises marked by traffic cones or markers. The examiner will explain how each exercise is to be done. You will be scored on your ability to properly perform each exercise. Failure of any skill test ends the test and a retest fee is due for each retest. *See Section 11 for skill test information.*

**Driving test.** You drive on a DMV-specified route. The test is about 45 to 60 minutes long and includes left and right turns, intersections, railroad crossings, curves, up and down grades, rural or semi-rural roads, city multilane streets,

and freeway driving. If you fail the driving test, a retest fee is charged for each additional driving test. *See Section 12 for driving test information.*

## CDL Restrictions

Your CDL will be restricted to the type of vehicle you use for the driving test. For example, if your test vehicle does not have air brakes you will be restricted to driving vehicles without air brakes. If your passenger transport vehicle carries 15 persons or less including the driver, you will be restricted to driving a small size bus.

You may take the law test at any DMV office. Office hours vary. Please go online at [www.dmv.ca.gov](http://www.dmv.ca.gov) or call 1-800-777-0133 to make an appointment.

The driving test is given by appointment only at one of the offices listed on page 5.

## Additional Requirements

All commercial vehicle drivers must:

- Be a California resident before applying for a California CDL.
- Disclose all states in which they were previously licensed during the past ten years and surrender all out-of-state driver licenses (current or expired), if any.
- Certify that they do not have a driver license from more than one state or country.
- Notify their home state Department of Motor Vehicles of any conviction which occurred in other states within 30 days of the conviction.
- Notify their employer of any conviction within 30 days of the conviction using form Report of Traffic Conviction (DL 535).
- Notify their employer of any revocation, suspension, cancellation, or disqualification before the end of the business day following the action.
- Give their employer a 10-year employment history of commercial driving, if applying for a job as a driver.

## Sanctions/Disqualifications

Please see the charts on pages 16 to 18 for required sanctions and disqualifications.

## Violation Point Counts

Convictions that occur while you are driving a commercial vehicle or as a holder of a commercial driver license are retained on your driving record as listed below:

- Major violations and disqualification actions, 55 years
- Out-of-service violations and disqualification actions, 15 years
- Accidents, serious violations and disqualification actions, 10 years
- Railroad grade crossings and disqualification actions, 4 years
- Minor convictions, 3 years

A traffic conviction for driving unsafely counts as one point. Any accident you contributed to or were responsible or at fault for, is normally counted as one point. If you are convicted of reckless driving, of driving under the influence of alcohol and/or drugs, or of hit-and-run driving, you are charged two points.

If you get too many points, you lose your privilege to drive. You are considered a **negligent operator** of a commercial motor vehicle when your driving record shows the following point counts:

- 4 points in 12 months
- 6 points in 24 months
- 8 points in 36 months

You may be entitled to a higher point count (6, 8, or 10 points) if you request and appear for a hearing and if 4, 6, or 8 points were not obtained in a Class C vehicle.

A violation received in a commercial vehicle carries one and one-half times the point count. A Class A or B driver *who does not have a special certificate or an endorsement* may be allowed two additional points before being considered a negligent operator.

Convictions reported by other states are added to your driving record and may result in license sanctions. If you have an out-of-state CDL, any conviction while operating in California, will be reported to your home state.

**NOTE:** Commercial drivers may not attend a traffic violator school to have an offense dismissed for any traffic violation. (VC §42005[c])

## State Laws And Rules

All commercial drivers must know the state laws limiting the size and weight of vehicles and loads. All commercial vehicles must stop at locations posted for CHP testing and inspection. (VC §§2802 – 2805, 2813)

Any officer, who has reason to believe that a commercial vehicle is not safely loaded or that the height, width, length, or weight of a vehicle and load is unlawful, is authorized to require the driver to stop and submit to an inspection, measurement, or weighing of the vehicle. The officer may have the driver stop in a suitable area and reload or remove any part of the load.

Any person driving a commercial vehicle over a highway or bridge illegally is liable for all damage caused to the highway or bridge. When the driver is not the owner of the vehicle but is operating it with the permission of the owner, the owner and driver may both have to pay for the damage.

### Vehicle Idling Restrictions

Commercial diesel-fueled vehicles with a GVWR greater than 10,000 pounds are subject to the following idling restrictions. You may **not**:

- idle the vehicle's primary diesel engine for greater than five minutes at any location. (For exceptions visit the California Air Resources Board website at: [www.arb.ca.gov/toxics/idling/idling.htm](http://www.arb.ca.gov/toxics/idling/idling.htm))

- operate a diesel-fueled auxiliary power system which powers a heater, air conditioner, or any additional equipment for sleeper-berth equipped vehicles during sleeping or resting periods for greater than five minutes at any location within 100 feet of a restricted area.(i.e., homes and schools).

When at a school or within 100 feet of a school, drivers of school buses and other diesel powered vehicles must turn off the engine upon arrival, and restart the engine no more than 30 seconds before leaving. Public transit buses may idle up to 10 minutes prior to passenger boarding or when passengers are aboard. Drivers are subject to both civil and criminal penalties for violation(s) of this law.

The California Air Resources Board conducts random inspections of heavy duty trucks and buses at CHP weigh stations. They inspect for emissions and tampering of emission systems. Penalties for failing the emissions inspection or for tampering with emission systems start at \$300. For further information visit [www.arb.ca.gov/msprog/hdvip/hdvip.htm](http://www.arb.ca.gov/msprog/hdvip/hdvip.htm) or call 1-800-END-SMOG.

### Length Of Vehicle/Loads–Single Vehicle

The maximum length for a **single vehicle** is 40 feet. This length may be exceeded by parts complying with fender and mudguard provisions of the California Vehicle Code.

**NOTE:** Some vehicles are conditionally exempted from the 40 foot maximum length (i.e., semitrailers, buses, housecars).

The front bumper of a vehicle must not extend more than two feet ahead of fenders, cab, or radiator, whichever is foremost.

On a bus, a front and/or rear safety bumper may extend an additional foot, and a wheel chair lift may extend up to 18 inches ahead of the bus. Additional extensions up to 36 inches in front or ten feet in the rear of some buses may be added to transport bicycles.

## Length Of Vehicle/Loads– Combination Vehicles

In a **combination of vehicles**, auxiliary parts or equipment which do not provide space for carrying a load or are not used to support or carry the vehicle may exceed the single vehicle length limit, but the combination may not exceed the length limit for combinations.

An articulated bus or trolley coach cannot exceed a length of 60 feet.

A semitrailer being towed by a motor truck or truck tractor may exceed 40 feet when certain conditions are met. (VC §35400b[4])

A combination of a truck tractor and a trailer coupled together shall not exceed a total length of 65 feet except as provided in VC §§35401 and 35401.5.

A combination of vehicles consisting of a truck tractor, a semitrailer, and a trailer cannot be longer than 75 feet, providing the length of either trailer does not exceed 28 feet 6 inches.

If posted, cities and counties may prohibit a combination of vehicles in excess of 60 feet in length on highways they control.

Other exceptions can be found in VC §35401.5. Extension devices are allowed with restrictions. See VC §35402.

The **load** length on any vehicle or combination of vehicles may not be more than 75 feet long measured from the front of vehicle or load to the back of vehicle or load.

## Length Exceptions

Some length exceptions are listed below:

- If the load consists only of poles, timbers, pipes, integral structural materials, or single unit component parts, including: missile components, aircraft assemblies, drilling equipment, and tanks not exceeding 80 feet in length; provided they are being transported on one of the following:

- pole or pipe dolly or other legal trailer used as a pole or pipe dolly pulled by a motor vehicle.
- semitrailer.
- semitrailer and a pole or pipe dolly pulled by a truck tractor to haul flexible integral structural material. (VC §35414)
- Public utilities. Refer to VC §35414(B) for load exceptions.
- The load on any vehicle or combination of vehicles must not extend more than three feet beyond the foremost part of the front bumper or tires. There are exceptions for booms or masts of shovels or cranes, or water well drilling and servicing equipment. (VC §35407) A load composed solely of vehicles may extend four feet ahead of the front tires or the front bumper.
- The load on any single vehicle may not extend to the rear, beyond the last point of support, more than two-thirds the length of the wheel base of the vehicle. On a semitrailer, the wheelbase extends from the center of the last axle of the towing vehicle to the center of the last axle on the semitrailer.

## Width Of Vehicles And Loads

The outside width of the body of the vehicle or load must not exceed 102 inches (8½ feet). The width of a vehicle with pneumatic (air filled) tires, measured from the outside of one wheel to the outside of the opposite wheel, must not exceed 108 inches (9 feet).

Permitted devices limited to door handles, hinges, cable cinchers, chain binders, and placard holders may extend three inches (six inches on one side for vehicles used for recreational purposes) on each side of the vehicle or load.

Required devices limited to lights, mirrors, or other devices may extend up to 10 inches on each side.

Cities and counties may post highways, which they control, to permit wider vehicles, but may also prohibit vehicles wider than 96 inches (8 feet).

Special mobile equipment and special construction and highway maintenance equipment may not be more than 120 inches (10 feet) wide.

Motor coaches or buses may be 102 inches wide. When operated by common carriers for hire in urban or suburban service, they may be 104 inches wide.

When a vehicle is carrying loosely piled agricultural products such as hay, straw, or leguminous plants in bulk rather than crated, baled, boxed, or stacked, the load and the racks that hold the load, may be no more than 120 inches wide.

A special trip permit may be obtained from the California Department of Transportation (Caltrans) to transport trusses and similar one-piece construction components up to 12 feet wide. (VC §35780.5)

**Variations for Farm Equipment.** (VC §§36000 and 36600) Implements of husbandry (farm equipment) are generally exempted from width and length limitations if they are being operated, transported, or towed over a highway incidental to normal farming operations. Owners and operators of such equipment should refer to the Vehicle Code provisions which apply. A Caltrans transportation permit may be necessary.

### Height Of Vehicles And Loads

The vehicle height limit and/or load limit, measured from the surface of the roadway on which the vehicle stands, is 14 feet.

\* Weight limitations by local ordinance do not prevent commercial vehicles from entering posted streets or highways by direct route to (a) make pickups or deliveries of goods, wares, and merchandise, (b) deliver materials for bona fide construction, repair, etc. of a structure for which a permit has been obtained, or (c) make public utility construction or repairs.

Exceptions:

- Double deck buses may not exceed 14 feet, 3 inches.
- Farming equipment moved incidentally over a highway.

### Weight Limits—General

Caltrans has authority to post signs at bridges and along state highways stating the maximum weight they will sustain. Such weight may be greater or lesser than the maximum weight limits for a vehicle specified in the Vehicle Code. (VC §35550-557)

Counties and cities may post higher or lower weight limits along highways and at bridges they control. Alternate routes may be given for vehicles which are too heavy for posted highways and bridges.\*

### Axle Weight Limits

The gross weight which can be carried by the wheels of any one axle must not exceed 20,000 pounds (20,500 pounds for buses). Additionally, the load limit stated by the tire manufacturer (molded on at least one sidewall) shall not be exceeded.

The weight carried by the wheel or wheels on one end of an axle must not exceed 10,500 pounds. This limitation does not apply to vehicles transporting livestock. (VC §35550)

Combinations of vehicles made up of a trailer or semitrailer, and each vehicle in the combination, must meet either the weight provisions of VC §35551 or the following:

- The gross weight placed on a highway by the wheels on any one axle of a vehicle must not exceed 18,000 pounds. The gross weight on any one wheel, or wheels, supporting one end of an axle and resting on a roadway must not exceed 9,500 pounds.
- Exceptions:
  - the gross weight placed on a highway by the wheels on any front steering axle of a motor vehicle must not exceed 12,500 pounds.



- vehicles carrying livestock are exempt from the gross weight limit which applies to a wheel at one end of an axle.

A complete listing of vehicles exempt from front axle weight limits can be found in VC §35551.5(b).

The total gross weight, with load, placed on a highway by any two or more consecutive axles of a combination of vehicles, or a vehicle in the combination, where the distance between the first and last axles of the two or more consecutive axles is 18 feet or less, must not exceed that given for the respective distance as shown in the table in VC §35551.5(c).

When the distance between the first and last axles is more than 18 feet, use the table shown in VC §35551.5(d).

### Weight Limit–Logs

Weight limits for vehicles transporting logs are contained in VC §§35552 and 35785. Such additional weight may not be transported on interstate highways.

### Weight To Axle Ratio (VC§35551)

Highways and bridges are designed to carry only a certain amount of weight per foot of distance between axles. Vehicles carrying heavy loads must not put too much weight on any point. The Vehicle Code shows limitations in the tables found in VC §§35551 and 35551.5.

The total gross weight in pounds placed on the highway by any group of two or more consecutive axles must not exceed that given for the respective distance in that table.

In addition to the weight specified in the previously mentioned table, two consecutive sets of tandem axles may carry a gross weight of 34,000 pounds each, if the distance between the first and last axles of the sets of axles is 36 feet or more. The gross weight on each set of tandem axles must not exceed 34,000 pounds and the gross weight on two consecutive sets of tandem axles must not exceed 68,000 pounds. (VC §35551[b])

### Loading/Unloading (VC §35553)

Load limits are not enforced when vehicles are loading or unloading in the immediate vicinity of a loading or unloading area.

A driver moving a load under a special permit may not change the route. **Exception:** to avoid violating a local city traffic regulation, the driver may detour the route on nonresidential streets only and return to the route as soon as possible.

### Penalties For Weight Restriction Violations

A driver who changes from the permitted route for an extralegal load, without a peace officer's authorization to do so, is guilty of a misdemeanor.

### CHP Uniform Weight Standard

A standard for enforcing weight laws has been established by the CHP. The standard states, "Vehicles weighing in excess of the legal limits by 100 pounds or more shall not be permitted to proceed until the overload has been adjusted or removed."

In practice, CHP will allow for a 200 pound *variation factor*. After applying the variation factor, any vehicle exceeding the axle weight, axle group weight, or gross weight limits by 100 pounds or more will be issued a citation and required either to adjust the load to make it legal or obtain an overweight permit before proceeding.

Hazardous materials cargoes may be allowed to proceed unless unloading or load adjustment can be handled with reasonable safety to the driver and the public.

Livestock and field-loaded bulk perishable agricultural products destined for human consumption being transported from the field to the first point of processing have a special exemption. The vehicles transporting livestock and perishable agricultural products

will be cited and allowed to proceed as long as the weight does not exceed legal limits by 1,000 pounds on any axle or axle group of a single truck or 2,000 pounds gross weight on a combination of vehicles.

## Permits

Transporting an oversize extralegal load without a permit is punishable by a \$500 fine or six months in jail or both. Also, excess load penalties may be imposed.

It is against the law in California to drive or move, on any street or highway, any vehicle which is wider, higher, or heavier than the limits described here. Permits for oversized vehicles may be obtained from:

- Caltrans—for state highways
- The city or county—for city or county highways.

## Motor Carrier Permits

Any person who operates any commercial motor vehicle either for hire or privately (not for hire) must obtain a motor carrier permit (MCP). (VC §34620)

The MCP definition for a commercial motor vehicle is any:

- Self-propelled vehicle listed in VC §34500(a), (b), (f), (g), and (k).
- Motor truck with two or more axles weighing more than 10,000 lbs. GVWR.
- Other motor vehicle used to transport property for hire.

**NOTE:** An MCP commercial motor vehicle does not include vehicles operated by household goods carriers (PUC §5109), pickup trucks (VC §471), or two-axle daily rental trucks (noncommercial use) weighing less than 26,001 lbs. gross.

To obtain MCP forms and information, contact [www.dmv.ca.gov](http://www.dmv.ca.gov) or write or call:

DMV MCP MS G875  
PO Box 932370  
Sacramento, CA 94232-3700  
(916) 657-8153

## Speed Limits

The maximum speed limit in California is 55 miles per hour (mph) for the following listed vehicles (VC §22406):



- Any truck or truck tractor having three or more axles.
- Any vehicle pulling any other vehicle.
- A school bus transporting any pupil.
- A farm labor vehicle transporting passengers.
- Any vehicle transporting explosives.
- A trailer bus.

For all other vehicles, the maximum speed limit on most California highways is 65 mph. However, for two-lane undivided highways, the maximum speed limit is 55 mph, unless posted for a higher speed. On some highways the maximum speed limit is 70 mph, but only if there are signs posted showing 70 mph.

No person shall drive at such a slow speed as to impede or block normal and reasonable movement of traffic, except when reduced speed is necessary for safe operation or for compliance with the law or when the size and weight of the vehicle or combination makes reduced speed unavoidable.

## Right Lane Rule

Vehicles listed in VC §22406 must be driven in the designated lane or lanes when signs are posted.

When no signs are posted, these vehicles must be driven in the right-hand traffic lane or as close as possible to the right edge or curb. On a divided highway with four or more traffic lanes in one direction, these vehicles may also be driven in the lane just to the left of the

right-hand lane. When overtaking or passing another vehicle going in the same direction, drivers of such vehicles must use either: (1) the designated lane, (2) the lane just to the left of the right-hand lane, or (3) the right-hand traffic lane when such use is permitted.

### Designated System Access

This does not apply to a driver who is: (1) preparing for a left- or right-hand turn, (2) in the process of entering or exiting a highway, or (3) driving in a lane other than the right-hand lane “to continue on the intended route.”

Buses, except school buses or trailer buses, may drive in any lane as long as they are not towing any other vehicle.

Movement off or onto the designated (freeways/highways) system by larger trucks is allowed only at interchanges or exits which have the following signs:

Movement is allowed along signed routes to reach terminals. Terminals are locations where:

- Freight is consolidated.
- Full loads are off-loaded.
- Vehicle combinations are regularly maintained, stored, or manufactured.



Movement is allowed up to one mile from the identified exits or entrances leading to or from specified highways to obtain:

- Food
- Fuel
- Lodging
- Repairs



### Slow Vehicle Rule

On a two-lane highway where passing is unsafe, a slow-moving vehicle with five or more vehicles behind it must turn off the roadway at the nearest place designated by signs as a turnout, or wherever sufficient area for a safe turnout exists, to let the following vehicles pass.

### Hours Of Service

You are required to comply with California’s driver hours of service regulations when you are involved in **INTR**Astate commerce. You are considered to be involved in intrastate commerce when you do not:

- Cross the state line.
- Transport cargo which originated from another state.
- Transport cargo destined outside of California.
- Transport any hazardous substance or waste. (49 CFR 171.8)

### Other Rules

You are required to comply with federal hours of service regulations when you are involved in **INTER**state commerce. You are considered to be involved in interstate commerce when the cargo you transport:

- Originates out of state.
- Is destined out of state.
- Consists of hazardous substances or wastes. (49 CFR 171.8)
- Any combination of the above.

### Driver’s Record Of Duty Status

The California Highway Patrol is authorized to develop additional safety and driving regulations. (VC §§34501 and 34501.2)

A driver’s record of duty status must be used to record all of the driver’s hours. Drivers of commercial vehicles must be in compliance with the hours of service requirements of the *Code of Federal Regulations* (CFR), Title 49, §395.8 and the *California Code of Regulations* (CCR), Title 13, §§1201–1213.

A driver’s record of duty status, in duplicate, must be kept by each driver and each co-driver while driving, on duty but not driving, or resting in a sleeper berth. The record of duty status **must be presented for inspection immediately** upon request by any authorized CHP employee, any regularly employed and

salaried police officer, or deputy sheriff. There may be instances when you do not need to maintain a record of duty status.

### Accident Reporting

Every driver involved in an accident which results in death, injury, or property damage over \$750 must report the accident on a Report of Traffic Accident Occurring in California (SR 1) to DMV. The report forms are available at DMV and CHP offices.

You (or your authorized representative) must submit the report within 10 days of the accident whether you caused the accident or not and even if the accident occurred on private property. This form is required in addition to any other report made to or by the police, CHP, or your insurance company if the accident resulted in any damage over \$750 and/or an injury or death. If you do not report the accident to DMV, your driving privilege will be suspended.

**NOTE:** CDL holders may downgrade to a noncommercial license during any mandatory

### Hours of Service

Condition	FEDERAL (Interstate commerce)	CALIFORNIA (Intrastate commerce)
Driving time	You may not drive for more than 11 hours following 10 consecutive hours off duty.	You may not drive for more than 12 hours following 10 consecutive hours off duty.
On duty time	You may not drive beyond the 14th hour after coming on duty following 10 hours off duty. You may perform work, except for driving, after being on duty for 14 hours.	You may not drive after having been on duty for 16 hours. You may perform work, except for driving, after being on duty for 16 hours.
Multiple day on duty time limitations	You are not eligible to drive after having been on duty for 60 hours in a 7-day period. However, if a motor carrier has commercial motor vehicles operating 7 days a week, the driver is not eligible to drive after having been on duty for 70 hours in an 8-day period. A driver may restart a 7/8 consecutive day period after taking 34 or more consecutive hours off duty.	You are not eligible to drive after having been on duty for 80 hours in any 8 consecutive day period or if transporting farm products after having been on duty 112 hours in any consecutive 8-day period.  For truck drivers, any period of 8 consecutive days may end with the beginning of any off-duty period of 34 or more consecutive hours.
Off duty time	After driving for 11 hours or being on duty for 14 hours, you may not drive again until you have had 10 consecutive hours off duty.  <b>Exception:</b> If the truck is equipped with a sleeper berth, these 10 hours may be broken up into 2 periods provided one is not less than 8 hours.	After driving for 12 hours or being on duty for 16 hours, you may not drive again until you have had 10 consecutive hours off duty.  <b>Exception:</b> If the truck is equipped with a sleeper berth, these 10 hours may be broken up into 2 periods, provided one period is not less than 8 hours.
Adverse driving condition	You may drive an additional 2 hours if you encounter adverse weather conditions which were not apparent at the start of the trip.	You may drive an additional 2 hours if you encounter adverse weather conditions which were not apparent at the start of the trip.  Regardless of the adverse conditions, you are not allowed to drive for more than 14 hours or after having been on duty more than 16 hours.

**NOTE:** The changes to hours of service (HOS) rules do not affect bus drivers, at this time. For up-to-date HOS rules, visit [www.fmcsa.dot.gov](http://www.fmcsa.dot.gov) or [www.chp.ca.gov](http://www.chp.ca.gov).

suspension period to be eligible to obtain a restricted license. All tests and fees will be required to upgrade when eligible.

California law states that you must notify your employer within five days if you have an accident while driving your employer's vehicle. (VC §16002) However, your employer may require you to notify him or her immediately.

## Financial Responsibility Requirements

**Motor Carriers of Property.** Most commercial vehicles transporting property are under the regulation of the Department of Motor Vehicles, whose liability and property damage requirements are listed below. The following limits do not apply to pickup trucks as defined in VC §471 and two-axle daily rental trucks with a GVWR less than 26,001 pounds when operated in noncommercial use.

- Transporting general freight exclusively in vehicles under 10,000 pounds GVWR: \$300,000 combined single limit.
- Transporting general freight in vehicles having a GVWR of 10,000 pounds or more: \$750,000 combined single limit.
- Transporting petroleum products in bulk on the highways: \$500,000 for injury or death of one person, \$1,000,000 for injury or death to two or more persons, \$200,000 for damage to property, or \$1,200,000 combined single limit.
- Transporting oil, hazardous materials or waste: combined single limit of \$1,000,000.
- Transporting hazardous substances, compressed gas, liquefied compressed gas in cargo tanks, portable tanks, or hopper-type vehicles with capacities in excess of 3,500 water gallons; or transporting Class A or B explosives, poison gas, or highway route controlled quantities of radioactive materials: combined single limit of \$5,000,000.

Information on transporting hazardous materials or wastes may be obtained from the Department of Toxic Substances Control (DTSC) and the CHP.

**NOTE:** Not all coverage requirements are listed in this section. For questions related to motor carriers, call the DMV Motor Carrier Permit Branch at (916) 657-8153.

Financial responsibility may be maintained by one of the following:

- An MCP Certificate of Insurance (DMV 65).
- A surety bond.
- Qualifying as a self-insurer.

Whenever DMV determines or is notified that a motor carrier's certificate of insurance or surety bond will lapse or end, DMV will suspend the permit. (VC §34630[c]) To avoid permit suspension, ask your insurance provider to submit evidence of valid liability coverage.

## Proof Of FR Before A Driving Test

Drivers must show evidence of financial responsibility prior to taking the driving test. In addition to the list above, evidence is also met if the vehicle(s):

- Displays a CAL-T number issued to highway carriers by the PUC.
- Displays the CA number issued by CHP and DMV for the Motor Carrier Permit.
- Is owned, or leased by, or under the direction of, the United States or any public entity (displays "E" plates).

**A driver is disqualified from operating a Commercial Motor Vehicle (CMV) if convicted of any of the following offenses while operating either a COMMERCIAL or NONCOMMERCIAL motor vehicle (non-CMV):**

<i>Offense</i>	<i>1<sup>st</sup> conviction or DUI test refusal in CMV</i>	<i>1<sup>st</sup> conviction or DUI test refusal in non-CMV</i>	<i>1<sup>st</sup> conviction or DUI test refusal in CMV transporting Hazmat</i>	<i>2<sup>nd</sup> conviction or DUI test refusal in separate incident of any of these offenses in CMV</i>	<i>2<sup>nd</sup> conviction or DUI test refusal in separate incident of any of these offenses in non-CMV</i>
Under the influence of alcohol	1 year	1 year	3 years	Life	Life
Under the influence of controlled substance	1 year	1 year	3 years	Life	Life
BAC of 0.04% or higher while operating CMV	1 year	Not applicable	3 years	Life	Not applicable
Refusing to take DUI test required by implied consent laws	1 year	1 year	3 years	Life	Life
Leaving the scene of an accident	1 year	1 year	3 years	Life	Life
Using vehicle in felony <b>not</b> involving a controlled substance	1 year	1 year	3 years	Life	Life
Driving CMV while DL is revoked, suspended, or canceled <b>or</b> when disqualified from operating a CMV	1 year	Not applicable	3 years	Life	Not applicable
Negligent operation of CMV causing a fatality	1 year	Not applicable	3 years	Life	Not applicable
Using vehicle in felony involving a controlled substance	Life	Life	Life	Life	Life

Synopsis of Table 1 Section 383.51 Federal Motor Carrier Safety Administrat

**A driver is disqualified from operating a Commercial Motor Vehicle (CMV) if convicted of any of the following SERIOUS offenses**

<i>Offense</i>	<i>2<sup>nd</sup> conviction in separate incident within 3 years of any of these offenses in a CMV</i>	<i>2<sup>nd</sup> conviction in separate incident within 3 years of any of these offenses in a non-CMV, if conviction results in revocation, cancellation, or suspension of all driving privileges</i>	<i>3<sup>rd</sup> or subsequent conviction in separate incident within 3 years of any of these offenses in a CMV</i>	<i>3<sup>rd</sup> or subsequent conviction in separate incident within 3 years of any of these offenses in a non-CMV, if conviction results in revocation, cancellation, or suspension of all driving privileges</i>
Speeding 15 mph or more above the posted speed limit	60 days	60 days	120 days	120 days
Reckless driving	60 days	60 days	120 days	120 days
Making improper or erratic lane changes	60 days	60 days	120 days	120 days
Following too closely	60 days	60 days	120 days	120 days
Violating a traffic law which causes a fatal accident	60 days	60 days	120 days	120 days
Driving CMV without obtaining a CDL	60 days	Not applicable	120 days	Not applicable
Driving CMV without CDL in possession	60 days	Not applicable	120 days	Not applicable
Driving CMV without proper class CDL and/or endorsements	60 days	Not applicable	120 days	Not applicable

Synopsis Table 2 Section 383.51 Federal Motor Carrier Safety Administration

**A driver is disqualified from operating a Commercial Motor Vehicle (CMV) if convicted of any of the following RAILROAD-HIGHWAY GRADE CROSSING offenses (either federal, state, or local):**

<i>Offense</i>	<i>1<sup>st</sup> conviction</i>	<i>2<sup>nd</sup> conviction in separate incident within 3 years of any of these offenses</i>	<i>3<sup>rd</sup> or subsequent conviction in separate incident within 3 years of any of these offenses</i>
Fails to slow down to check for approaching train. <b>NOTE:</b> Regulations may not require the driver to stop.	No less than 60 days	No less than 120 days	No less than 1 year
Fails to stop before reaching the crossing if tracks are not clear. <b>NOTE:</b> Regulations may not require the driver to stop.	No less than 60 days	No less than 120 days	No less than 1 year
Fails to stop before crossing the tracks. <b>NOTE:</b> Regulations require the driver to stop.	No less than 60 days	No less than 120 days	No less than 1 year
Fails to allow enough space to completely cross the tracks without stopping.	No less than 60 days	No less than 120 days	No less than 1 year
Fails to obey traffic device or directions from a railroad crossing guard	No less than 60 days	No less than 120 days	No less than 1 year
Cannot cross tracks because of insufficient undercarriage clearance	No less than 60 days	No less than 120 days	No less than 1 year

Synopsis of Table 3 Section 383.51 Federal Motor Carrier Safety Administration

**A driver is disqualified from operating a Commercial Motor Vehicle (CMV) if convicted of any of the following OUT-OF-SERVICE orders:**

<i>Offense</i>	<i>1<sup>st</sup> conviction</i>	<i>2<sup>nd</sup> conviction in separate incident within 10 years of any of these offenses</i>	<i>3<sup>rd</sup> or subsequent conviction in separate incident within 10 years of any of these offenses</i>
Violates a driver or vehicle out-of-service order while transporting non-HazMat	No less than 90 days or more than 1 year	No less than 1 year or more than 5 years	No less than 3 years or more than 5 years
Violates a driver or vehicle out-of-service order while transporting HazMat or 16 or more passengers, including the driver.	No less than 180 days or more than 2 years	No less than 3 years or more than 5 years	No less than 3 years or more than 5 years

Synopsis of Table 4 Section 383.51 Federal Motor Carrier Safety Administration



## Section 2: Driving Safely

This section is for all commercial drivers

This section contains general knowledge and safe driving practices which all commercial drivers should know. You must take a test on this information to get a CDL.

This section does not contain information on air brakes, combination vehicles (tractor semitrailer, doubles/triples, or towing trailers), or buses. You must read other sections to get this information if it applies to the type of vehicle(s) you wish to drive.

We have included some basic information on hazardous materials and wastes. Section 9 has more detailed information on hazardous materials/wastes.

### Vehicle Inspections

**Safety.** Safety is the most important and obvious reason to inspect your vehicle. A vehicle defect found during an inspection could save you problems later. You could have a breakdown on the road that will cost time and dollars, or even worse, a crash. Federal and state laws require inspection by the driver. Federal and state inspectors also inspect commercial vehicles. An unsafe vehicle can be put “out of service” until the driver or owner has it repaired. Do **not** risk your life or the life of another in an unsafe vehicle.

#### Pre-Trip Inspections

**Pre-trip Inspection.** Do a pre-trip inspection before each trip to find problems that could cause a crash or a breakdown. A pre-trip inspection should be done routinely before operating the vehicle. Drivers must complete a vehicle inspection report in writing each day. Review the last vehicle inspection report. Make

sure the vehicle has been released for service by the maintenance mechanics, if applicable. The motor carrier must repair any items in the report that affects safety and certify on the report that repairs were made or were unnecessary. Remember, when you get behind the wheel, you (not the mechanic) are responsible for the safe operation of the vehicle. If the defects have been repaired, sign the previous driver’s report. There is detailed information on pre-trips in Section 10 of this handbook.

#### En Route Inspection

**During a trip** you should:

- Watch gauges for signs of trouble.
- Use your senses to check for problems (look, listen, smell, and feel).
- Check critical items when you stop.
  - tires, wheels, and rims
  - brakes
  - lights and reflectors
  - brake and electrical connections to the trailer
  - trailer coupling devices
  - cargo securement devices

#### After Trip Inspections

**After-Trip Inspection and Report.** Inspect the vehicle at the end of the trip, day, or tour of duty for each vehicle you operated. It may include filling out a *vehicle condition report* listing any problems you find. The inspection report helps the motor carrier know when the vehicle needs repairs.

## Inspections—What To Look For

As you approach the vehicle, notice its general condition. Look for damage. Is the vehicle leaning to one side? Look under the vehicle for fresh oil, coolant, grease, or fuel leaks. Check the area around the vehicle for hazards to vehicle movement such as people, other vehicles, objects, low hanging wires, or tree limbs, etc.

Check that the parking brakes are on and/or the wheels are chocked. You may have to raise the hood, tilt the cab (secure loose objects first), or open the engine compartment door. Check the following:

- **Tire Problems.** It is dangerous to drive with bad tires.  
**Remember:** After a tire has been changed, stop a short while later and recheck the tightness of the wheel fasteners.
- **Wheel and Rim Problems.** A damaged rim can cause a tire to lose pressure or come off.
- **Bad Brake Drum or Shoe Lining Problems.** It is dangerous to drive with brake problems.

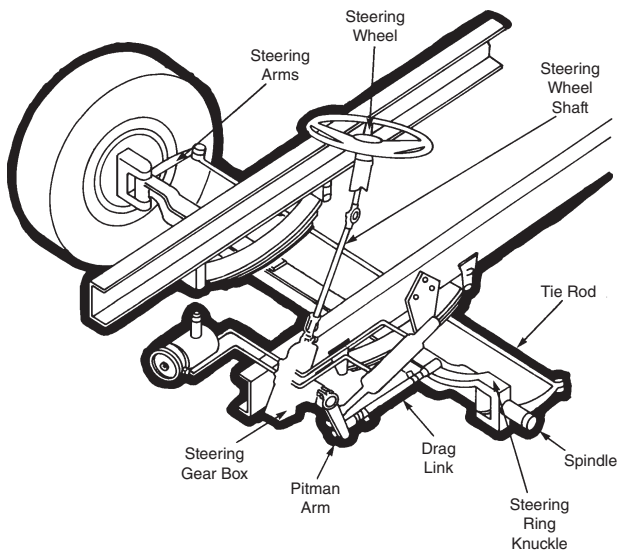
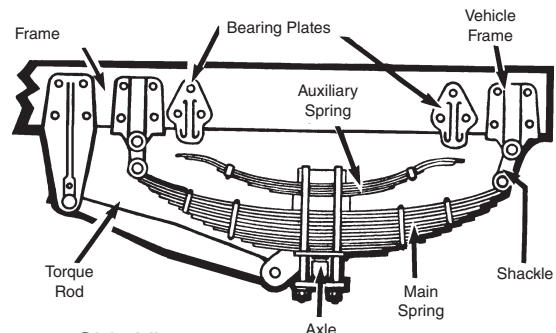
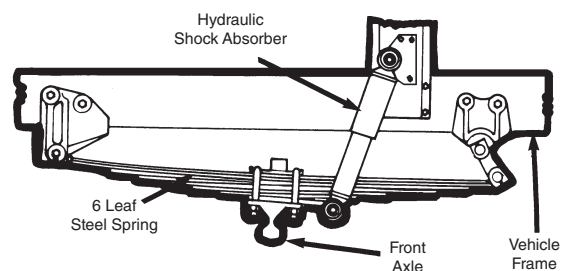

Figure 2-1

- **Steering System Defects**—(Figure 2-1) A poorly maintained steering system can cause steering problems.
- **Suspension System Defects**—(Figures 2-2 through 2-4) The suspension system supports the vehicle and its load and keeps the axles in place. Broken suspension parts can be extremely dangerous.
- **Exhaust System Defects.** A broken exhaust system can let poisonous fumes into the cab or sleeper berth.
- **Emergency Equipment.** Vehicles should be equipped with:
  - fire extinguisher(s) (when required)
  - spare electrical fuses (unless equipped with circuit breakers)
  - warning devices for parked vehicles (i.e., three reflective warning triangles)
- **Cargo (trucks).** Before each trip, inspect cargo for:
  - overloading
  - correct balance
  - securement
  - proper papers and placarding (if the cargo contains hazardous materials or wastes which require placarding)



Side View

Figure 2-2

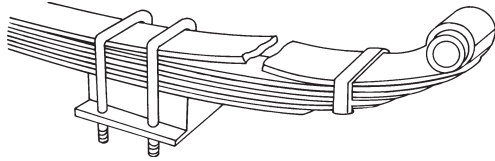
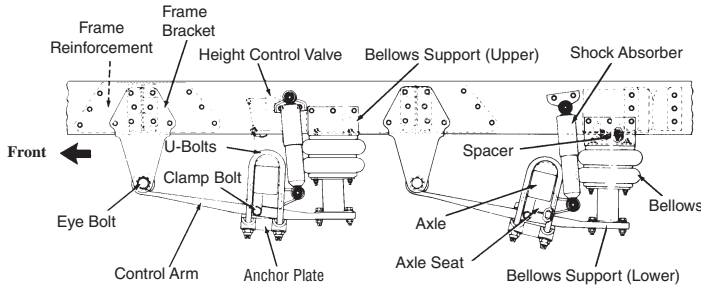

Figure 2-3



**Air Suspension Diagram**  
Figure 2-4

- **Lights and Reflectors.** Reflectors should be clean and the proper color (red at rear). Verify that the following lights are clean, operating, and the proper color:
  - headlights (high and low beams)
  - turn signals
  - brake lights
  - running lights
  - emergency flashers

**NOTE:** All corresponding dash display lights should be checked also.

### Get In Vehicle

- Turn off lights not needed for driving.
- Check for all required papers, trip manifests, permits, etc.
- Secure all loose articles in cab that might interfere with operation of the controls or hit you in a crash.
- Start the engine.

### Check The Brake System

**Test Hydraulic Brakes.** If the vehicle has hydraulic brakes, pump the brake pedal three times. Then apply firm pressure to the pedal and hold for five seconds. The pedal should not move. If it does, there may be a leak or other problem which must be repaired before driving.

If the vehicle has air brakes, follow the checklist marked with an asterisk (\*) described in Section 5 of this handbook.

**Test Parking Brake.** First fasten your seat belt. Then allow the vehicle to move forward slowly and apply the parking brake. If the vehicle does not stop, get the brake repaired before you drive the vehicle.

**Test Service Brake.** First fasten your seat belt. Then allow the vehicle to move forward about five miles per hour and push the brake pedal firmly. If the vehicle “pulls” to one side or the other, or if there is any unusual brake pedal “feel” or delayed stopping action, the service brake may need repair before you drive the vehicle.

Buses must also be inspected for:

- Fire extinguisher.
- Passenger entry doors and emergency exits.
- Seats and bus interior.
- Baggage compartment.

If you see, hear, smell, or feel anything that might mean trouble—check it out. Do not drive an unsafe vehicle.

**Safety Inspection.** Truck and truck tractor drivers should inspect their vehicle within the first 25 miles of a trip and every 150 miles or every 3 hours (whichever comes first) after that.

In order to obtain a CDL, you will be required to pass a pre-trip vehicle inspection test. You will be tested to see if you know whether your vehicle is safe to drive. You will be asked to do a pre-trip inspection of your vehicle and explain to the examiner what you would inspect and why.

A pre-trip inspection should be done the same way each time so you will learn all the steps and be less likely to forget something. Section 10 of this handbook tells you what to inspect and how to inspect it.

## After-Trip Inspection And Report

You must make a written report each day on the condition of the vehicle(s) you drive. Report anything affecting safety which could lead to a mechanical breakdown.

The vehicle inspection report tells the vehicle owner about problems that may need repair. Keep a copy of your report in the vehicle for one day. That way, the next driver can learn about any problems you have found.

## Basic Vehicle Control

To drive a vehicle safely, you must be able to control its speed and direction. Safely operating a commercial vehicle requires skill in:

- Accelerating
- Steering
- Backing safely
- Shifting gears
- Braking/controlling speed

Fasten your seat belt when on the road. Apply the parking brake when you leave your vehicle.

### Accelerating

Don't roll back when you start. You may hit someone behind you. Partly engage the clutch before you take your right foot off the brake. Set the parking brake whenever necessary to keep from rolling backward. Release it only when you have applied enough engine power to keep from rolling backward. On a tractor-trailer equipped with a trailer brake hand valve, the hand valve can be applied to keep from rolling backward.

Speed up smoothly and gradually so the vehicle does not jerk. Rough acceleration can cause damage to the coupling when pulling a trailer. It is also a common cause of passenger injuries on buses.

Speed up very gradually when traction is poor, as in rain or snow. If you give the vehicle too much power, the drive wheels may spin and you could lose control. If the drive wheels begin to spin, take your foot off the accelerator.

### Steering

Hold the wheel firmly with both hands. Your hands should be on opposite sides of the wheel. If you hit a curb or a pothole, the wheel could pull away from your hands unless you have a firm hold.

### Backing Safely

Because you cannot see everything behind your vehicle, backing is always dangerous. Avoid backing whenever you can. When you park, try to park so you will be able to pull forward when you leave. When you have to back, here are a few simple safety rules:

- Look at your path.
- Back slowly, using your mirrors.
- Back and turn toward the driver's side whenever possible.
- Use a helper whenever possible.

**Look at Your Path.** Look at your line of travel before you begin. Get out and walk around the vehicle. Check your clearance to the sides and overhead in and near the path your vehicle will take.

**Back Slowly.** Always back as slowly as possible. Use the lowest reverse gear so that you can easily correct any steering errors before you get too far off course. You can also stop quickly if necessary.

**Back and Turn Toward the Driver's Side.** Back to the driver's side so you can see better. Backing toward the right side is very dangerous because you cannot see as well.

Remember to always back in the direction that gives you the best vision.

## Backing With A Trailer

**Backing with a Trailer.** When backing a car, straight truck, or bus, turn the steering wheel toward the direction you want to go. When backing a trailer, turn the steering wheel in the opposite direction. Once the trailer starts to turn, you must turn the wheel the other way to follow the trailer.

Whenever you back with a trailer, try to position your vehicle so you can back in a straight line. If you must back on a curved path, back to the driver's side so you can see. Back slowly so you can make corrections before you get too far off course.

**Use the Mirrors.** The mirrors will help you see whether the trailer is drifting to one side or the other.

**Correct Drift Immediately.** As soon as you see the trailer getting off the proper path, correct it by turning the steering wheel in the direction of the drift.

**Pull Forward.** When backing, make pull-ups to reposition your vehicle when needed.

**Use a Helper.** Use a helper when you can. He or she can see blind spots that you can't. The helper should stand near the back of the vehicle where you can see him or her. Before you begin backing, work out a set of hand signals that you both understand. Agree on a signal for STOP.

## Shifting Gears

Shifting gears correctly is important. If you can't get your vehicle into the correct gear while driving, you will have less control.

### Manual Transmissions

**Basic Method for Shifting Up.** Most heavy vehicles with manual transmissions require double clutching to change gears. This is the basic method:

- Release accelerator, push in clutch, and shift to neutral at the same time.

- Release clutch.
- Let engine and gears slow down to the revolutions per minute (rpm) required for the next gear (this takes practice).
- Push in clutch and shift to the higher gear at the same time.
- Release clutch and press accelerator at the same time.

There are two ways of knowing when to shift:

- Engine speed or rpm. Study the owner's manual for your vehicle and learn the operating rpm range. Watch your tachometer, and shift up when your engine reaches the top of the range. (Some newer vehicles use "progressive" shifting: the rpm at which you shift becomes higher as you move up in the gears. Find out what is right for your vehicle.)
- Road speed or miles per hour (mph). Learn the correct speed for each gear. Then, by using the speedometer, you will know when to shift up.

With either method, you may learn to use engine sounds to know when to shift.

### Basic Procedures for Shifting Down

- Release accelerator, push in clutch, and shift to neutral at the same time.
- Release clutch.
- Press accelerator. Increase engine and gear speed to the rpm required in the lower gear.
- Push in clutch and shift to lower gear at the same time.
- Release clutch and press accelerator at the same time.

Downshifting, like upshifting, requires knowing when to shift. Use either the tachometer or the speedometer and downshift at the right rpm or road speed. Some special conditions where you should downshift are:

- Before starting down a hill. Slow down and shift down to a speed that you can control without using the brakes hard.

Otherwise the brakes can overheat and lose their braking power. Downshift before starting down the hill. Make sure you are in a low enough gear, usually lower than the gear required to climb the same hill. The braking effect of the engine is greatest when it is near the governed rpms and the transmission is in the lower gears. Save your brakes so you will be able to stop or slow as required by road and traffic conditions.

- Before entering a curve. Slow down to a safe speed, and downshift before entering the curve. This lets you use some power through the curve to help the vehicle be more stable while turning. It also lets you speed up as soon as you are out of the curve.

### **Multispeed Rear Axles And Auxiliary Transmissions**

Multispeed rear axles and auxiliary transmissions are used on many vehicles to provide extra gears. You usually control them by a selector knob or switch on the gearshift lever of the main transmission. There are many different shift patterns. Learn the right way to shift gears in the vehicle(s) you drive.

### **Automatic Transmissions**

Some vehicles have automatic transmissions which let you select a low range for greater engine braking when going down grades. The lower ranges prevent the transmission from shifting up beyond the selected gear (unless the governor rpm is exceeded). It is very important to use this braking effect when going down grades.

### **Automated Transmissions**

Automated transmissions combine the convenience of an automatic transmission with the control of a manual transmission. An automated transmission has a clutch and gear selection lever. However, the only time the clutch is used is to start and stop the

vehicle. Once the vehicle is started, sensors constantly monitor the vehicle's speed and rpms. Gear shifting is automatic. DMV imposes a restriction when a vehicle equipped with an automated transmission is used for a driving test (because the clutch is only used to start or stop the vehicle).

### **Retarders**

Some vehicles have "retarders." Retarders help slow a vehicle, reducing the need for using your brakes. They reduce brake wear and give you another way to slow down. There are many types of retarders (exhaust, engine, hydraulic, electric). All retarders can be turned on or off by the driver. On some vehicles the retarding power can be adjusted. When turned "on," retarders apply braking power to the drive wheels only whenever you let up on the accelerator pedal all the way.

**Caution.** When the drive wheels have poor traction, the retarder may cause them to skid. You should turn the retarder off whenever the road is wet, icy, or snowy.

### **Seeing**

To be a safe driver and to help avoid accidents, you need to know what is going on all around your vehicle. Not looking properly is a major cause of accidents. All drivers look ahead; but many do not look far enough ahead.

### **Seeing Ahead**

**Importance of Looking Far Enough Ahead.** Because stopping or changing lanes can take a lot of distance, knowing what traffic is doing on all sides of you is very important. You need to look well ahead to make sure you have room to make these moves safely.

**How Far Ahead to Look.** Most good drivers look 12 to 15 seconds ahead. That means looking ahead the distance you will travel in 12 to 15 seconds. At lower speeds, that is about one block. At highway speeds, it is about a quarter of a mile. If you are not looking that

far ahead, you may have to stop too quickly or make quick lane changes. Looking 12 to 15 seconds ahead does not mean that you should not pay attention to things that are closer. Good drivers shift their attention back and forth, near and far.

**What to Look For in Traffic.** Be especially alert when nearing freeway on ramps. Look for vehicles entering the highway or moving into your lane or turning. Watch for brake lights of vehicles ahead. By looking far enough ahead you can change your speed or change lanes if necessary to avoid a problem.

**Road Conditions.** Look for hills and curves—anything for which you will have to slow or change lanes. Pay attention to traffic signals and signs. If a light has been green for a long time, it will probably change before you get there. Start slowing down and be ready to stop. Traffic signs may alert you to road conditions where you may have to change speed.

### Seeing Behind And To The Sides

It is important to know what is going on behind and to the sides. Check your mirrors regularly. Check more often in special situations.

Every California registered motor vehicle must have at least two mirrors, including one attached to the left-hand side, and located to give a clear view of the roadway to the rear for a distance of at least 200 feet. Both left- and right-hand rear view mirrors are required on a motor vehicle which is constructed or loaded to obscure the driver's view to the rear, or which is towing a vehicle or load which blocks the view. (VC §26709)

**Mirror Adjustment.** Mirror adjustment should be checked prior to the start of any trip and can only be checked accurately when the trailer(s) are straight. You should check and adjust each mirror as needed.

**How to Use Mirrors.** Use mirrors correctly by quickly checking them often and understanding what you see. When you use your mirrors while

driving on the road, check quickly. Look back and forth between the mirrors and the road ahead. Do not focus on the mirrors for too long. Otherwise, you will travel quite a distance without knowing what is happening ahead.

Many large vehicles have curved (convex, “fisheye,” “spot,” “bugeye”) mirrors that show a wider area than flat mirrors. This is often helpful. But remember, everything appears smaller in a convex mirror than it would if you were looking at it directly. Also, things seem farther away than they really are. It is important to realize this and to allow for it.

**Regular Checks.** You need to make regular checks of your mirrors to be aware of traffic and to check your vehicle.

**Traffic.** Check the mirrors for vehicles on either side and in back of you. In an emergency, you will need to know whether you can make a quick lane change or stop. Use your mirrors to spot overtaking vehicles. Remember, there are blind spots that your mirrors cannot show you. Check your mirrors regularly to know where other vehicles are around you and to see if they move into your blind spots.

**Check your vehicle.** Use the mirrors to keep an eye on your tires, it is one way to spot a tire fire. Use the mirrors to check open cargo. Look for loose straps, ropes, or chains. Watch for a flapping or ballooning tarp.

**Special Situations.** Special situations require more than regular mirror checks. These are lane changes, turns, merges, and tight maneuvers.

**Lane changes.** Check your mirror to make sure no vehicle is alongside you or about to pass you. Check your mirrors:

- Before you change lanes to make sure there is enough room and signal at least 100 feet before turning. On the freeway, it is best to signal at least five seconds before changing lanes.
- After you have signaled, check to see that the lane is clear and no one has moved

into your blind spot.

- Right after you start the lane change to double check that your path is clear.
- After you complete the lane change to be sure you turned off your signal lights.

**Turns.** When turning, check your mirrors to make sure the rear of your vehicle will not hit anything.

**Merges.** When merging, use your mirrors to make sure the gap in traffic is large enough for you to enter safely.

**Tight Maneuvers.** Any time you are driving in close quarters, check your mirrors often. Make sure you have enough clearance for any maneuver you wish to make.

## Communicating

Other drivers will not know what you are going to do until you tell them.

### Signal Your Intentions

Signaling what you intend to do is important for everyone's safety. Here are some general rules for signaling.

**Turns.** There are three good rules for using turn signals:

1. **Signal early.** Signal several seconds before you turn. It is the best way to keep others from trying to pass you.
2. **Signal continuously.** You need both hands on the wheel to turn safely. Do not cancel the signal until you have completed the turn.
3. **Cancel your signal.** Turn the signal off after you have turned.

For information on vehicles which must be equipped with lamp turn signal systems and two stop lamps see VC §§24951 and 24600.

**Lane Changes.** Use your turn signal before changing lanes. Change lanes slowly and smoothly. That way a driver you did not see may have a chance to avoid your vehicle.

**Slowing Down.** Warn drivers behind you when you need to slow down. A few light taps on the brake pedal—enough to flash the brake lights—should warn following drivers. Use the 4-way flashers when you are stopped. Warn other drivers in any of the following situations:

- **Trouble ahead.** The size of your vehicle may make it hard for drivers behind you to see hazards ahead of you. If you see a hazard that will require slowing down, warn the drivers behind by flashing your brake lights.
- **Tight turns.** Most passenger vehicle drivers do not know how slow you must go to make a tight turn in a large vehicle. Give drivers behind you warning by braking early and slowing gradually.
- **Stopping on the road.** Truck and bus drivers sometimes stop in the road to unload cargo or passengers or to stop at a railroad crossing. Warn other drivers by flashing your brake lights. Do not stop suddenly.

**Don't Direct Traffic.** Some drivers try to help out others by signaling when it is safe to pass. You should not do this. You could cause an accident and be held liable for the costs.

### Communicating Your Presence

Other drivers may not notice your vehicle even when it is in plain sight. Let them know you are there to help prevent accidents.

**When Passing.** Whenever you are about to pass a vehicle, pedestrian, motorcyclist, or bicyclist, assume they do not see you. They could suddenly move in front of you. When it is legal, tap the horn lightly or, at night, quickly flash your lights from low to high beam and back. Drive carefully enough to avoid an accident even if they don't see or hear you.

**When it is Hard to See.** At dawn or dusk or in rain or snow, you need to make your vehicle easier to see. If you are having trouble seeing other vehicles, other drivers will have



trouble seeing you. Turn on your lights. Use the headlights, not just the identification or clearance lights. Use the low beams; high beams can bother people at dawn or dusk as well as at night.

**When Parked at the Side of the Road.** When you pull off the road and stop, be sure to turn on the 4-way flashers. This is very important at night. Do not trust the taillights to give warning. Drivers have crashed into the rear of a parked truck because they thought it was moving.

If you must stop on the road or the shoulder of a road, put out your reflective triangles within ten minutes. Place your warning devices at the following locations:

- On a two-lane road with traffic in both directions or on an undivided highway, place warning devices within ten feet of the front or rear corners to mark the location of the vehicle and 100 feet behind and ahead of the vehicle, on the shoulder or in the lane in which you stopped. (Figure 2-5)
- On the traffic side of the vehicle, within ten feet of the front or rear corners, to mark the location of the vehicle. (Figure 2-5)
- About 100 feet behind and ahead of the vehicle, on the shoulder or in the lane where you are in. (Figure 2-6)
- Back beyond any hill, curve, or other obstruction that prevents other drivers from seeing the vehicle within 500 feet. (Figure 2-6)
- If you must stop on or by a one-way or divided highway, place warning devices 10 feet, 100 feet, and 200 feet toward the approaching traffic. (Figure 2-7)

Carry the triangles with the reflective side toward the oncoming traffic when placing them, for your own safety. The other drivers will be able to see you.

## Emergency Warning Device Placement

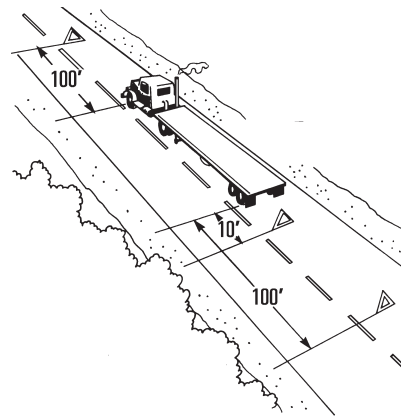

Figure 2-5 Two Lane or Undivided Highway

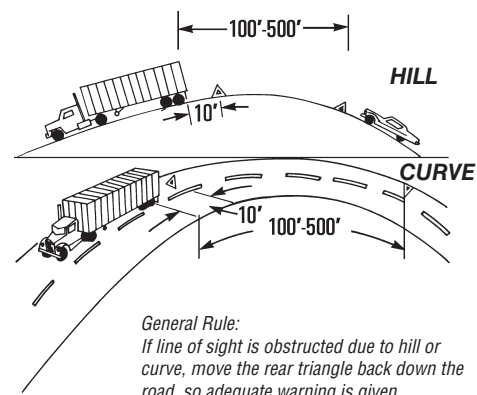

Figure 2-6 Obstructed View

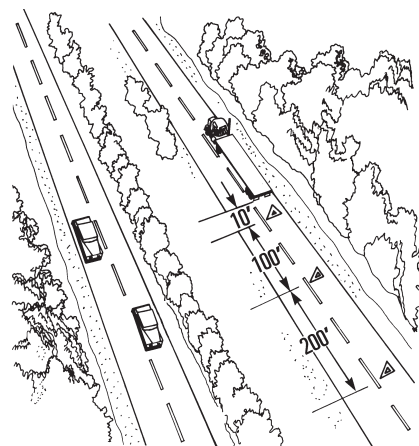

Figure 2-7 One way or Divided Highway

**Use Your Horn Only When Needed.** Your horn can let others know you are there and can help avoid an accident. However, it can also startle others and could be dangerous if used unnecessarily.

## Controlling Speed

Driving too fast is a major cause of fatal crashes. You must adjust your speed depending on several conditions which include: traction, curves, visibility, traffic, and hills.

### Speed And Stopping Distances

There are three things that add up to total stopping distance: Perception Distance + Reaction Distance + Braking Distance = Total Stopping Distance.

- Perception distance. This is the distance your vehicle moves from the time your eyes see a hazard until your brain knows it. The perception time for an alert driver is about 3/4 second. At 55 mph you travel 60 feet in 3/4 second.
- Reaction distance. The distance traveled from the time your brain tells your foot to move from the accelerator until your foot is actually pushing the brake pedal. The average driver has a reaction time of 3/4 second. This accounts for an additional 60 feet traveled at 55 mph.
- Braking distance. The distance it takes to stop once the brakes are put on. At 55 mph on dry pavement with good brakes, it can take a heavy vehicle about 170 feet to stop. (About 4 3/4 seconds.)
- Total stopping distance. At 55 mph it will take about 6 seconds to stop and your vehicle will travel about the distance of a football field ( $60 + 60 + 170 = 290$  feet).

*Refer to Page 73 for stopping distances with air brakes.*

**Control and Stopping Requirements. (VC §26454)** The service brake must hold the vehicle or combination of vehicles stationary on any grade on which it is operated under all conditions of loading or unloading.

The service brakes of every motor vehicle or combination of vehicles must be capable of stopping from an initial speed of 20 miles per hour as follows MSD (Maximum Stopping Distance in feet):

- Passenger vehicle—25 MSD
- Single motor vehicle with manufacturer's GVWR of less than 10,000 pounds—30 MSD
- Single motor vehicle with manufacturer's GVWR of 10,000 pounds or more, or any bus—40 MSD
- Combination of vehicles consisting of a passenger vehicle or any motor vehicle with a manufacturer's GVWR of less than 10,000 pounds in combination with any trailer, semitrailer, or trailer coach—40 MSD
- All other combinations of vehicles—50 MSD

**The effect of speed on stopping distance.** When you double your speed, it will take about four times the distance to stop and the vehicle will have four times the destructive power if it crashes. High speeds increase stopping distances greatly. By slowing down a little, you can gain a lot in reduced braking distance.

**The effect of vehicle weight on stopping distance.** If a vehicle is heavier, brakes have to work harder (and absorb more heat) to stop. The brakes, tires, springs, and shock absorbers on heavy vehicles are designed to work best when the vehicle is fully loaded. Generally, *empty* trucks require *greater* stopping distances because an empty vehicle has less traction. It can bounce and lock up its wheels, giving much poorer braking. (This is not usually the case with buses.)

## Matching Speed To The Road Surface

You cannot steer or brake a vehicle unless you have traction. Traction is friction between the tires and the road. These are some of the road conditions which reduce traction and call for lower speeds:

**Slippery Surfaces.** It will take longer to stop and it will be harder to turn without skidding when the road is slippery. You must drive slower to be able to stop in the same distance as on a dry road. Wet roads can double the stopping distance. Reduce speed by about one third (i.e., slow from 55 mph to about 35 mph) on a wet road. On packed snow, reduce speed by half, or more. If the surface is icy, reduce speed to a crawl and stop driving as soon as you can safely do so to install chains, if necessary.



Sometimes it is difficult to know if the road is slippery. Here are some examples of slippery roads:

- **Shaded areas.** Shady parts of the road will remain icy and slippery long after open areas have melted.
- **Bridges.** When the temperature drops, bridges will freeze before the road will. Be especially careful when the temperature is close to 32° F.
- **Melting ice.** Slight melting will make ice wet. Wet ice is much more slippery than ice that is not wet.
- **Black ice.** Black ice is a thin layer that is so clear you can see the road underneath it. It makes the road look wet. Any time the temperature is below freezing and the road looks wet, watch out for black ice.
- **Vehicle icing.** An easy way to check for ice is to open the window and feel the front of the mirror, mirror support, or antenna. If there is ice on the mirror, the road surface is probably starting to ice up.

- **Just after rain begins.** Right after it starts to rain, the water mixes with oil left on the road by vehicles. This makes the road very slippery. If it continues, it will wash the oil away.

**Hydroplaning.** In some weather, water or slush collects on the road. When this happens, your vehicle can hydroplane. It is like water skiing; the tires lose their contact with the road and have little or no traction. You may not be able to steer or brake. You can regain control by releasing the accelerator and pushing in the clutch. This will slow your vehicle and let the wheels turn freely. If the vehicle is hydroplaning, do not use the brakes to slow down. If the drive wheels start to skid, push in the clutch to let them turn freely.

It does not take a lot of water to cause hydroplaning. Hydroplaning can occur at speeds as low as 30 mph if there is a lot of water. It is more likely to occur if tire pressure is low or the tread is worn. (The grooves in a tire carry away the water; if they aren't deep, they don't work well.) Be especially careful driving through puddles. Puddles are often deep enough to cause hydroplaning.

## Speed And Curves

Drivers must adjust their speed for curves in the road. If you take a curve too fast, two things can happen. The tires can lose their traction and continue straight ahead, so you skid off the road. Or, the tires may keep their traction and the vehicle will roll over. Tests have shown that trucks with a high center of gravity can roll over traveling at the posted speed limit for the curve.

Slow to a safe speed before you enter a curve. Braking in a curve is dangerous because it is easier to lock the wheels and cause a skid. Slow down as needed—never exceed the posted speed limit for the curve. (The speed zone signs posted at curves are for smaller vehicles.) Drive in a gear that will let you accelerate slightly in the curve. This will help you keep control.

## Speed And Distance Ahead

You should always be able to stop within the distance you can see ahead. At night, low beams let you see about 250 feet ahead. During the day, fog, rain, or other conditions may require that you slow down to be able to stop in the distance you can see.

## Speed And Traffic Flow

When you are driving in heavy traffic, the safest speed is that of other vehicles. Vehicles going the same direction at the same speed are not likely to run into one another. Drive at the speed of the traffic, if you can do so without traveling at an illegal or unsafe speed. Keep a safe following distance.

The main reason drivers exceed speed limits is to save time. But anyone trying to drive faster than the speed of traffic will not be able to save much time. The risks involved are not worth it. Go with the flow of traffic—it is safer and easier. If you go faster than the speed of other traffic:

- You will have to keep passing other vehicles. This increases the chance of an accident.
- It is more tiring. Fatigue increases the chance of an accident.

## Overtaking or Following Another Vehicle.

You may not overtake and pass another vehicle which is moving at less than 20 mph on a grade (outside a business or residential district) unless you can pass that vehicle at least 10 mph faster than it is travelling and the pass can be completed within one quarter mile. (VC §21758)

You must not follow the vehicles listed below any closer than 300 feet. The rule does not apply during overtaking and passing, when there are two or more lanes for traffic in each direction, or in a business or residential district. (VC §21704)

- A motor truck or truck tractor having three or more axles or any motor truck or truck tractor towing any other vehicle.
- A passenger vehicle or bus towing any other vehicle.
- A school bus transporting any school pupil.
- A farm labor vehicle when transporting passengers.
- A vehicle transporting explosives.
- A trailer bus.

When large vehicles are being driven in caravan on the open highway, at least 100 feet must be left between them to allow other vehicles to overtake and pass them. (VC §21705)

## Speed On Downgrades

Your vehicle's speed will increase on downgrades because of gravity. Your most important objective is to select and maintain a speed that is not too fast for the:

- Total weight of the vehicle and cargo.
- Length and steepness of the grade.
- Road conditions and weather.

If a speed limit is posted, or there is a sign indicating a maximum safe speed, never exceed the posted speed. Also look for and heed warning signs indicating the length and steepness of the grade. You must use the braking effect of the engine as the principal way of controlling your speed on downgrades. The braking effect of the engine is greatest when it is near the governed rpms and the transmission is in the lower gears. Save your brakes so you will be able to slow or stop as required by road and traffic conditions.

Slow the vehicle and shift your transmission to a low gear *before* starting down the grade and use the proper braking techniques.

More information on going down steep hills safely is on page 38 in the section on "Mountain Driving."

## Managing Space

A safe driver keeps space all around the vehicle. When things go wrong, space gives you time to think and to take action.

To have space available when something goes wrong, you need to manage space. While this is true for all drivers, it is very important for large vehicles. They take up more space and they require more space for stopping and turning.

### Space Ahead

Of all the space around your vehicle, it is the area ahead of the vehicle—the space you are driving into—that is the most important.

**The Need for Space Ahead.** You need space ahead in case you must suddenly stop. According to accident reports, the vehicle that trucks and buses most often run into is the one in front of them. The most frequent cause of accidents is following too closely. Remember, if the vehicle ahead of you is smaller than yours, it can probably stop faster than you can. You may crash into it if you are following too closely.

**How Much Space?** How much space should you keep in front of you? One good rule says you need at least one second for each 10 feet of vehicle length at speeds below 40 mph. At higher speeds, you must add one second for safety. For example, if you are driving a 40-foot vehicle, you should leave 4 seconds between you and the vehicle ahead. In a 60-foot rig, you will need 6 seconds. Over 40 mph, you would need 5 seconds for a 40-foot vehicle and 7 seconds for a 60-foot vehicle.

To know how much space you have, wait until the vehicle ahead passes a shadow on the road, a pavement marking, or some other obvious landmark. Then count off the seconds like this: “one thousand-and-one, one thousand-and-two” and so on, until you reach the same spot. Compare your count with the rule of one second for every 10 feet of length. If you are

driving a 40-foot truck and only counted up to 2 seconds, you are too close. Drop back a little and count again until you have 4 seconds of following distance (or 5 seconds, if you are going over 40 mph). After a little practice, you will know how far back you should be. Remember to add one second for speeds above 40 mph. Also remember that when the road is slippery, you need much more space to stop.

### Space Behind

You cannot stop others from following you too closely. But there are things you can do to make it safer.

**Stay to the Right.** Heavy vehicles are often tailgated when they cannot keep up with the speed of traffic such as when you are going uphill. If a heavy load is slowing you down, stay in the right lane if you can. Going uphill, you should not pass another slow vehicle unless you can get around it quickly and safely.

**Handle Tailgaters Safely.** In a large vehicle, it is often hard to see whether a vehicle is close behind you. You may be tailgated:

- When you are traveling slowly. Drivers trapped behind slow vehicles often follow too closely.
- In bad weather many passenger vehicle drivers follow large vehicles closely, especially when it is hard to see the road ahead.

If you find yourself being tailgated, here are some things you can do to reduce the chances of an accident:

- Avoid quick changes. If you have to slow down or turn, signal early and reduce speed very gradually.
- Increase your following distance. Opening up room in front of you will help you to avoid having to make sudden speed or direction changes. It also makes it easier for the tailgater to get around you.
- Do not speed up. It is safer to be tailgated at a low speed than a high speed.

- Avoid tricks. Do not turn on your taillights or flash your brake lights. Follow the suggestions above to avoid accidents.

When you follow too closely and another driver “cuts” in front of you, the normal reaction is to slam on your brakes and swerve out of the way. Swerving out of the way can often result in cutting someone else off, possibly driving off the roadway, or driving into another lane of traffic. It might also result in the vehicle behind you crashing into you or other vehicles around you.

If another driver “cuts” in front of you, it is better to *take your foot off the gas*. This creates space between your vehicle and the other driver without swerving into another lane. Do not overreact if you are cut off. Plan your emergency escape route before the emergency happens.

### Space To The Sides

Commercial vehicles are often wide and take up most of a lane. Safe drivers will manage what little space they have. You can do this by keeping your vehicle centered in your lane, and avoid driving alongside other vehicles.

**Staying Centered in a Lane.** Keep your vehicle centered in the lane to keep safe clearance on either side. If your vehicle is wide, you have little room to spare.

**Traveling Next to Others.** There are two dangers in traveling alongside other vehicles:

- Another driver may change lanes suddenly and turn into you.
- You may be trapped when you need to change lanes.

Find an open spot where you are not near other traffic. When traffic is heavy, it may be hard to find an open spot. If you must travel near other vehicles, try to keep as much space as possible between you and them. Also, drop back or pull forward so that you are sure the other driver can see you.

**Strong Winds.** Strong winds make it difficult to stay in your lane. The problem is usually worse for lighter vehicles. This problem can be especially bad coming out of tunnels. Do not drive alongside others if you can avoid it.

### Space Overhead

Hitting overhead objects is a danger. Know the overhead clearance of the vehicle you are driving.

- Do not assume that the heights posted at bridges and overpasses are correct. Repaving or packed snow may have reduced the clearances since the heights were posted.
- The weight of a cargo van changes its height. An empty van is higher than a loaded one. Because you cleared a bridge when you were loaded does not mean that you can do it when you are empty.
- If you doubt you have safe space to pass under an object, go slowly. If you are not sure you can make it, do not try it. Take another route. Warnings are often posted on low bridges or underpasses, but sometimes they are not.
- Some roads can cause a vehicle to tilt. There can be a problem clearing objects along the edge of the road, such as signs or trees. Where this is a problem, drive a little closer to the center of the road.
- Before you back into an area, get out and check for overhanging objects such as trees, branches, or electric wires. It is easy to miss seeing them while you are backing. (Also check for other hazards at the same time.)

### Space Below

Many drivers forget about the space under their vehicles. That space can be very small when a vehicle is heavily loaded. Railroad tracks can stick up several inches. This is often a problem on dirt roads and in unpaved yards where the surface around the tracks can wear away. Do not take a chance on getting hung up. Drainage

channels across roads can cause some vehicles to drag. Cross such depressions carefully.

## Space For Turns

The space around a truck or bus is important when turning. Because of wide turning and offtracking, large vehicles can hit other vehicles or objects during turns.

**Right turns.** Here are some rules to help prevent right turn accidents:

- Turn slowly to give yourself and others more time to avoid problems.
- If you are driving a truck or bus that cannot make a right turn without swinging into another lane, turn wide as you *complete* the turn as shown in Figure 2-8. Keep the rear of your vehicle close to the curb. This will stop other drivers from passing you on the right.
- Do not turn wide to the left as you start the turn. A following driver may think you are turning left and try to pass you on the right. You may hit the other vehicle as you complete your turn.
- If you must cross into the oncoming lane to make a turn, look for vehicles coming toward you. Give them room to go by or to stop. However, do not back up for them, because you might hit someone behind you.

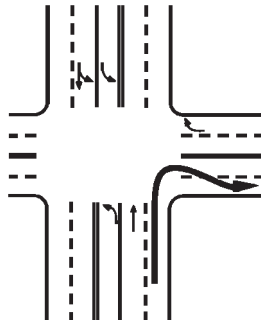

Figure 2-8

**Left turns.** Make sure you have reached the center of the intersection before you start a left turn. If you turn too soon, the left side of your vehicle may hit another vehicle because of offtracking. If you are turning into a multilane street, enter any lane that is safe and available to you.

If there are two turning lanes, you should use the right-hand turn lane as shown in Figure 2-9, because you may have to swing right to make the turn. Drivers on your right may be hard for you to see.

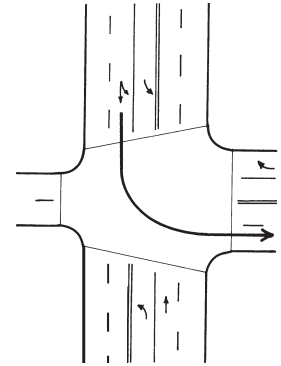

Figure 2-9

## Space To Cross Or Enter Traffic

Be aware of the size and weight of your vehicle when you cross or enter traffic. Here are some important things to keep in mind:

- Because of slow acceleration and the space large vehicles require, you need a much larger gap to enter traffic than you would in a smaller vehicle.
- Acceleration varies with the load. Allow more room if your vehicle is heavily loaded.
- Before you start across a road, make sure you can get all the way across before cross traffic reaches you. It is against the law to enter an intersection if you cannot get completely across *before* the light changes.

## Driving At Night

More than half of all traffic accidents happen at night. Drivers cannot see hazards as soon as in daylight, so they have less time to respond. Drivers caught by surprise are less able to avoid a crash. The problems of night driving involve the driver, the roadway, and the vehicle.

### Human Factors

**Vision.** People cannot see as well at night or in dim light. Also, the eyes need time to adjust to seeing in dim light.

**Glare.** Drivers can be blinded for a short time by bright light. It can take several seconds to recover from glare. Even two seconds of glare

blindness can be dangerous. A vehicle going 55 mph will travel more than half the distance of a football field during that time. Do not look directly at bright lights when driving. Look at the right-hand edge of the road or your traffic lane.

**Fatigue and Lack of Alertness.** Fatigue and lack of alertness are bigger problems at night. The body naturally wants to sleep. Most drivers are less alert at night, especially after midnight. This is particularly true if you have been driving for a long time. Drivers may not see hazards as soon or react as quickly, so the chance of an accident is greater. If you are sleepy, the only safe cure is to get off the road and get some sleep. If you don't, you risk your life and the lives of others.

## Roadway Factors

**Poor Lighting.** In the daytime there is usually enough light to see well. This is not true at night. Some areas may have bright street lights, but many areas will have poor lighting. On most roads you will probably have to depend entirely on your headlights.

Less light means you will not be able to see hazards as well as in daytime. Road users who do not have lights are hard to see. There are many accidents at night involving pedestrians, joggers, bicyclists, or animals that are hard to see.

Even when there are lights, the road scene can be confusing. Traffic signals and hazards can be hard to see against a background of signs, shop windows, and other lights.

When lighting is poor or confusing, drive slowly. Be sure you can stop within your sight distance.

**Drivers under the influence.** Drivers under the influence of alcohol and/or drugs are a hazard to themselves and to you. Be especially alert around the closing time of bars and taverns. Watch for drivers who have trouble staying in their lane or maintaining speed, stop without

reason, or show other signs of driving under the influence of alcohol and/or drugs.

## Vehicle Factors

**Headlights.** At night your headlights will usually be the main source of light for you and for others to see you. You cannot see as much with your headlights as you can see in the daytime. With low beams you can see ahead about 250 feet and with high beams about 350–500 feet. You must adjust your speed to keep your stopping distance within your sight distance. This means going slowly enough to be able to stop within the range of your headlights. Otherwise, by the time you see a hazard, you will not have time to stop.

Night driving can be more dangerous if you have problems with your headlights. Dirty headlights may give only half the light they should. This reduces your ability to see, and makes it harder for others to see you. Make sure your lights are clean and working and in adjustment. If out of adjustment, they do not give you a good view and they can blind other drivers.

You must turn on your headlights:

- from a half hour after sunset to a half hour before sunrise, or
- if snow, rain, fog, or other hazardous weather condition requires the use of windshield wipers, or
- when visibility is not sufficient to clearly see a person or a vehicle for a distance of 1,000 feet. (VC §§280 and 24400)

No vehicle may be driven with only parking lights on. However, they may be used as signals or when the headlamps are also lighted. (VC §24800)

**Other Lights. (VC §25100)** In order for you to be seen easily, the following must be clean and working properly:

- Reflectors.
- Marker and clearance lights.
- Taillights.
- Identification lights.



**Turn Signals and Brake Lights.** At night your turn signals and brake lights are even more important for telling other drivers what you intend to do. Make sure you have clean, working turn signals and stop lights.

**Windshields and Mirrors.** It is more important at night than in the daytime to have clean windshields and mirrors. Dirt on your windshield or mirrors can cause bright lights at night to create a glare of its own, blocking your view. Clean your windshield on the inside and outside for safe driving.

### Night Driving Procedures

Make sure you are rested and alert. If you are drowsy, sleep before you drive. Even a nap can save your life or the lives of others. If you wear eye glasses, make sure they are clean and unscratched. Don't wear sun glasses at night. Do a complete pre-trip inspection of your vehicle. Pay attention to checking all lights and reflectors and cleaning those you can reach.

**Avoid Blinding Others.** Glare from your headlights can cause problems for drivers coming toward you as well as drivers going in your direction. Dim your lights within 500 feet of an oncoming vehicle and when following another vehicle within 300 feet.

**Avoid Glare from Oncoming Vehicles.** Do not look directly at lights of oncoming vehicles. Look slightly to the right at a right lane or edge marking, if available. If other drivers don't put their low beams on, don't try to "get back at them" by putting your own high beams on. This increases glare for oncoming drivers and increases the chance of an accident.

**Use High Beams When You Can.** Many drivers make the mistake of always using low beams. This cuts down on your ability to see ahead. Use high beams when it is safe and legal to do so. Use them unless you are within 500 feet of an approaching vehicle or are following another vehicle within 300 feet. Also, don't let the inside of your cab get too bright. This makes it harder to see outside. Keep the interior light

off and adjust your instrument lights as low as you can and still be able to read the gauges.

**If You Get Sleepy, Stop Driving.** People often do not realize how close they are to falling asleep. If you look or feel sleepy, stop driving! You are in a very dangerous condition. The only safe cure is to sleep.

## Driving In Fog

The best advice for driving in fog is "Don't." It is better to pull off the road into a rest area or truck stop, if available, until visibility is better. If you must drive, be sure to consider the following:

- Obey all fog-related warning signs.
- Slow before you enter fog.
- Turn on all your lights. (Headlights should be on low beams.)
- Be prepared for emergency stops.

## Driving In Winter

Make sure your vehicle is ready for driving in winter weather. During the pre-trip inspection, pay extra attention to the following items.

### Vehicle Checks

**Coolant Level and Antifreeze.** Make sure the cooling system is full and there is enough antifreeze in the system to protect against freezing. This can be checked with a special coolant tester.

**Defrosting and Heating Equipment.** Check to see if the defrosters and heaters work. They are needed for safe driving. Make sure you know how to operate them. If you use other heaters and expect to need them (mirror heaters, battery box heaters, fuel tank heaters), check their operation.

**Wipers and Washers.** The windshield wiper blades must be in good condition. Make sure the wiper blades press against the window hard enough to wipe the windshield clean of snow. Make sure the windshield washer works and the washer reservoir is full. Use windshield

washer antifreeze to prevent freezing of the washer liquid. If you can't see well enough while driving (i.e., your wipers fail), stop safely and fix the problem.

**Tires.** Check the tread on your tires. The drive tires must provide traction to push the rig over wet pavement and through snow. The steering tires must have traction to steer the vehicle. Enough tread is especially important in winter conditions. You must have at least 4/32 inch tread depth in every major groove on the front tires and at least 2/32 inch on other tires. More would be better. Use a gauge to determine if you have enough tread for safe driving.

**Tire Chains.** You may find yourself in conditions where you can't drive without chains even to get to a place of safety. Carry the correct number of chains and extra cross links. Make sure they will fit your drive tires. Check the chains for broken hooks, worn or broken cross links, and bent or broken side chains. Learn how to put the chains on before you need to do it in snow or ice.

**Lights and Reflectors.** Make sure the lights and reflectors are clean. Lights and reflectors are especially important during bad weather. Check from time to time during bad weather to make sure they are clean and working.

**Windows and Mirrors.** Remove any ice, snow, etc. from the windshield, windows, and mirrors before starting. Use a windshield scraper, snow brush, and windshield defroster as necessary.

**Handholds, Steps, and Deck Plates.** Remove all ice and snow from hand holds, steps, and deck plates which you must use to enter the cab or to move about the vehicle. This will reduce the danger of slipping.

**Radiator Shutters and Winterfront.** Remove ice from the radiator shutters. Make sure the winterfront is not closed too tightly. If the shutters freeze shut or the winterfront is closed too much, the engine may overheat and stop.

**Exhaust System.** Exhaust system leaks are especially dangerous when cab ventilation is poor (windows rolled up, etc.). Loose connections can permit poisonous carbon monoxide to leak into your cab which will make you sleepy. In large amounts, it can kill you. Check the exhaust system for loose parts and for sounds and signs of leaks.

## Driving On Slippery Surfaces

**Slippery Surfaces.** Drive slowly and smoothly on slippery roads. If it is very slippery, you shouldn't drive at all. Stop at the first safe place. The following are some safety guidelines:

- **Start gently and slowly.** When first starting, get the feel of the road. Do not hurry.
- **Adjust turning and braking to conditions.** Make turns as carefully as possible. Do not brake any harder than necessary and do not use the engine brake or speed retarder. (They can cause the driving wheels to skid on slippery surfaces.)
- **Adjust speed to conditions.** Do not pass slower vehicles unless necessary. Go slowly and watch far enough ahead to keep a steady speed. Avoid having to slow down and speed up. Take curves at slower speeds and do not brake while in curves. Be aware that as the temperature rises to the point where ice begins to melt, the road becomes even more slippery and you must slow down even more.
- **Adjust space to conditions.** Do not drive alongside other vehicles. Keep a greater following distance. When you see a traffic jam ahead, slow down or stop and wait for it to clear. Try to anticipate stops early and slow down gradually.

**Wet Brakes.** When driving in heavy rain or deep standing water, your brakes will get wet. Water on the brakes can cause the brakes to be weak, to apply unevenly, or to grab. This can cause lack of braking power, wheel lockups, pulling to one side or the other, and a jackknife if you pull a trailer.

Avoid driving through deep puddles or flowing water if possible. If you cannot, you should:

- Slow down.
- Place transmission in a low gear.
- Gently put on the brakes. This presses linings against brake drums or discs and keeps mud, silt, and water from getting in.
- Increase engine rpm and cross the water while keeping light pressure on the brakes.
- When out of the water, maintain light pressure on the brakes for a short distance to heat them up and dry them out.  
**CAUTION:** Brake drums and linings can overheat if you do this for too long.
- Make a test stop when safe to do so. Check your mirrors to be sure no one is following, then apply the brakes to be sure they are working. If not, dry out further as described above.

## Driving In Very Hot Weather

During the pre-trip inspection, pay special attention to the following items:

### Vehicle Checks

**Tires.** Check the tire mounting and air pressure. Inspect the tires for overheating and tread separation every two hours or 100 miles when driving in very hot weather. Air pressure increases with temperature. Do not let air out or the pressure will be too low when the tires cool off. If a tire is too hot to touch, remain stopped until the tire cools off. Otherwise, the tire may blow out or catch fire. Pay special attention to recapped or retreaded tires. Under high temperatures, the tread may separate from the body of the tire.

**Engine Oil.** The engine oil helps keep the engine cool, as well as lubricating it. Make sure there is enough engine oil. If you have an oil temperature gauge, make sure the temperature is within the proper range while you are driving.

**Engine Coolant.** Before starting out, be sure the engine cooling system has enough water and antifreeze according to the engine manufacturer's directions. (Antifreeze helps the engine under hot conditions as well as cold conditions.) When driving in hot weather, check the water temperature or coolant temperature gauge more frequently. Make sure it remains in the normal range. If the gauge goes above the highest safe temperature, there may be something wrong that could lead to engine failure and possibly fire. Stop driving as soon as safely possible.

Some vehicles have sight glasses, see-through coolant overflow containers, or coolant recovery containers which permit checking coolant level while the engine is hot. If the container is not part of the pressurized system, the cap can be safely removed and coolant added even when the engine is at operating temperature. **Never remove the radiator cap or any part of the pressurized system until the system has cooled.** Steam and boiling water can spray under pressure and cause severe burns.

If coolant has to be added to a system without a recovery tank or overflow tank, follow these steps:

- Shut engine off.
- Wait until engine has cooled.
- Protect hands (use gloves or a thick cloth).
- Turn radiator cap slowly to the first stop, which releases the pressure seal.
- Step back while pressure is released from cooling system.
- When all pressure has been released, press down on the cap and turn it further to remove it.
- Visually check level of coolant.
- Replace cap and turn all the way to the closed position.

**Engine Belts.** Learn how to check V-belt tightness on your vehicle by pressing on the belts. Loose belts will not turn the water pump and/or fan properly. This will result in overheating. Also check belts for cracking or other signs of wear.

**Hoses.** Be sure the coolant hoses are in good condition because a broken hose can lead to engine failure and even fire.

**Watch for Bleeding Tar.** Tar in road surfacing frequently rises to the surface in very hot weather. Spots where tar “bleeds” to the surface are very slippery.

**Go Slow to Prevent Overheating.** High speeds create more heat for tires and the engine. In desert conditions, the heat may build up to the point where it is dangerous. The heat will increase chances of tire failure, tire fire, and engine failure.

## Mountain Driving

In mountain driving, the force of gravity plays a major role. The steeper the grade, the longer the grade and/or the heavier the load—the more you will have to use lower gears to climb hills or mountains. In going down steep hills, gravity will tend to speed you up. You must select an appropriate safe speed, then use a low gear, and use proper braking techniques. You should plan ahead and obtain information about any long steep grades along your planned route of travel. If possible, talk to other drivers who are familiar with the grades to find out what speeds are safe.

You must go slowly enough so your brakes can hold you back without getting too hot. If the brakes become too hot, they may start to “fade.” This means you have to apply them harder and harder to get the same stopping power. If you continue to use the brakes hard, they can keep fading (have less stopping power) until you cannot slow down or stop at all.

## Select A “Safe” Speed

Your most important consideration is to select a speed that is not too fast for the:

- Total weight of the vehicle and cargo
- Length and steepness of the grade
- Road conditions and weather

If a speed limit is posted, or there is a sign indicating maximum safe speed, never exceed the speed shown. Also, look for and heed warning signs indicating the length and steepness of the grade.

## Going Downhill In The Correct Gear

Use the braking effect of the engine as the principal way of controlling your speed. The braking effect of the engine is greatest when it is near the governed rpms and the transmission is in the lower gears. Save your brakes so you will be able to slow or stop as required by road and traffic conditions.

Slow the vehicle and shift the transmission to a low gear *before* starting down the grade. Do not try to downshift after your speed has already built up. You will not be able to shift into a lower gear. You may not even be able to get back into any gear and all engine braking effect will be lost. Forcing an automatic transmission into a lower gear at high speed could damage the transmission also and lead to loss of all engine braking effect.

With older trucks, a rule for choosing gears is to use the same gear going down a hill that you would need to climb the hill. However, new trucks have low friction parts and streamlined shapes for fuel economy. They may also have more powerful engines. This means they can go up hills in higher gears and have less friction and air drag to hold them back going down hills. For that reason, drivers of newer trucks may have to use lower gears going down a hill than needed to go up the hill. Find out what is right for your vehicle.

## Brake Fade Or Failure

When going downhill, brakes will always heat up. They are designed so brake shoes or pads rub against the brake drum or discs to slow the vehicle, which creates heat. Brakes are designed to take a lot of heat. However, brakes can fail from excessive heat if you try to slow down from a high speed too many times or too quickly. Brakes will fade when they get very hot and may not slow the vehicle.

Brakes also can fade because they are out of adjustment. To safely control a vehicle, every brake must do its share of the work. If some brakes are out of adjustment, they will not be doing their share. The other brakes can overheat and fade and there will not be enough braking available to control the vehicle(s). Brakes can get out of adjustment quickly, especially when they are used a lot; also, brake linings wear faster when they are hot. Check brake adjustment frequently.

## Proper Braking Technique

**Remember:** The use of brakes on a long and/or steep downgrade is only a supplement to the braking effect of the engine. Once the vehicle is in the proper low gear, the following is a proper braking technique:

- Apply the brakes just hard enough to feel a definite slowdown.
- When your speed has been reduced to approximately 5 mph below your “safe” speed, release the brakes. (This brake application should last for about three seconds.)
- When your speed has increased to your “safe” speed, repeat steps 1 and 2.

For example, if your “safe” speed is 40 mph, you would not apply the brakes until your speed reaches 40 mph. You now apply the brakes hard enough to gradually reduce your speed to 35 mph and then release the brakes. Repeat this as often as necessary until you have reached the end of the downgrade.

## Escape Ramps

Escape ramps have been built on many steep mountain grades, and are used to stop runaway vehicles safely without injuring drivers and passengers. Escape ramps use a long bed of loose, soft material (pea gravel or sand) to slow a runaway vehicle, sometimes in combination with an upgrade.

Know escape ramp locations on your route. Signs show drivers where ramps are located. Escape ramps save lives, equipment, and cargo. (Also see page 44.)

## Railroad Crossings

Railroad crossings are always dangerous. You must approach every railroad crossing expecting to see a train coming.

Never attempt to race a train to a crossing. It is extremely difficult to judge the speed of an approaching train.

Your speed should be based on your ability to see whether a train is approaching from any direction. You should be driving slowly enough so you can stop short of the tracks in case of an emergency.

Because of noise in the cab, you cannot expect to hear the train horn until the train is dangerously close to the crossing.

Do not rely solely upon the presence of warning signals, gates, or flagmen to warn of approaching trains.

Double tracks require a double check. Remember that a train on one track may hide a train on the other track. Look both ways before crossing. After one train has cleared a crossing, be sure no other trains are near before starting across the tracks.

Train yard areas and grade crossings in cities and towns are just as dangerous as rural grade crossings. Approach them with care.

A full stop is required at grade crossings whenever:

- The nature of the cargo makes a stop mandatory under state or federal regulations.
- Such a stop is otherwise required by law.

Railroad crossings with steep approaches can cause your unit to hang up on the tracks. Never permit traffic conditions to trap you in a position where you have to stop on the tracks. Be sure you can get all the way across the tracks before you start across.

Do not shift gears while crossing railroad tracks.

## Seeing Hazards

**What is a Hazard?** A hazard is any road condition, road obstacle, or other road user (driver, motorcyclist, bicyclist, or pedestrian) that is a possible danger. For example, a vehicle in front of you is headed toward the freeway exit, but the brake lights come on and the driver begins braking hard. This could mean that the driver is uncertain about taking the offramp and might suddenly return to the highway. This vehicle is a hazard. If the driver of the vehicle cuts in front of you, it is no longer just a hazard, it is an emergency.

**Seeing Hazards Lets You Be Prepared.** You will have more time to react if you see hazards before they become emergencies. In the example above, you might make a lane change or slow down if the vehicle suddenly cuts in front of you. Seeing this hazard gives you time to check your mirrors and signal for a lane change. Being prepared reduces the danger. Sudden braking or a quick lane change is much more likely to lead to an accident.

**Learning to See Hazards.** There are often clues that will help you see hazards. The more you drive, the better you can get at seeing hazards.

Slow down and be very careful if you see any of the following road hazards:

- **Work Zones.** Road work can create hazardous conditions with narrower lanes, sharp turns, or uneven surfaces. Other drivers are often distracted and drive unsafely. Workers and construction vehicles may get in the way. Drive slowly and carefully near work zones. Use your 4-way flashers or brake lights to warn drivers behind you.
- **Drop-Offs.** Sometimes the pavement drops off sharply near the edge of the road. Driving too near the edge can tilt your vehicle toward the side of the road. This can cause the top of your vehicle to hit roadside objects (signs, tree limbs). Also, it can be hard to steer as you cross the drop-off, either going off the road or coming back on.
- **Foreign Objects.** Things that have fallen on the road can be a danger to your tires and wheel rims and can damage electrical and brake lines. They can be caught between dual tires and cause severe damage. Some obstacles such as boxes and sacks, may appear harmless but can cause major damage if hit by the vehicle. It is important to remain alert so you can avoid these objects without any sudden moves or stops.
- **Offramps/Onramps.** Freeway and turnpike exits can be particularly dangerous for commercial vehicles. Offramps and onramps often have speed limit signs posted. Remember, these speeds may be safe for smaller vehicles, **but may not be safe for larger vehicles or heavily loaded vehicles.** Exits which go downhill and turn at the same time can be especially dangerous. The downgrade makes it difficult to reduce speed. Braking and turning at the same time can be a dangerous practice. Be sure to slow down **before** you enter the curved part of an offramp or onramp.

## Hazardous Situations

In order to protect yourself and others, you must recognize other drivers who may do something hazardous. Here are some clues:

**Blocked Vision.** People who cannot see others are dangerous. Be alert for drivers whose vision is blocked. Vans, loaded station wagons, and cars with the rear windows blocked are examples. Rental trucks should be watched carefully. Their drivers are often not used to the limited vision they have to the sides and rear of the truck. In winter, vehicles with frosted, ice-covered, or snow-covered windows are hazards.

Vehicles may be partly hidden by blind intersections or alleys. If you can see only the rear or front end of a vehicle but not the driver, then he or she cannot see you. Be alert because the driver may back out or enter into your lane. Always be prepared to stop.

Delivery truck drivers' vision is often blocked by packages or vehicle doors. Drivers of step vans, postal vehicles, and local delivery vehicles often are in a hurry and may suddenly step out of, or drive their vehicle into, the traffic lane.

Watch for movement inside parked vehicles or movement of the vehicle itself that shows people are inside. They may get out, or the vehicle may pull out into the traffic. Watch for brake lights, backup lights, exhaust, and other clues that a vehicle is about to move.

Be careful when approaching a stopped bus. Passengers may cross in front of or behind the bus and they often cannot see you.

Walkers, joggers, and bicyclists may be on the road with their back to the traffic, so they cannot see or hear you. This can be dangerous. On rainy days, pedestrians may not see you because of hats or umbrellas.

**Distractions.** Watch where drivers are looking. If they are looking elsewhere, they can't see you. Be alert even when they are looking

at you since they may believe they have the right-of-way.

**Children.** Children tend to move quickly without checking traffic. When playing with one another, they may not look for traffic.

**Talkers.** Drivers or pedestrians talking to one another may not be paying close attention to the traffic.

**Workers.** People working on or near the roadway are a hazard clue. The work creates a distraction for other drivers and the workers themselves may not see you.

**Ice cream truck.** Someone selling ice cream is a hazard clue. Children may be nearby and may not see you.

**Disabled Vehicle.** Drivers changing a tire or fixing an engine often do not pay attention to the dangers of roadway traffic. Jacked up wheels or raised hoods are hazard clues.

**Accidents.** People involved in the accident may not look for traffic. Passing drivers tend to look at the accident. People often run across the road without looking. Vehicles may slow or stop suddenly.

**Shoppers.** People in and around shopping areas are often not watching traffic because they are looking for stores or window shopping.

**Confused Drivers.** Confused drivers may change direction suddenly or stop without warning, often near freeway or turnpike interchanges and major intersections. Unexpected actions (stopping in the middle of a block, changing lanes for no apparent reason, backup lights suddenly go on) are clues to confusion. Hesitation is another clue, including driving very slowly, using brakes often, or stopping in the middle of an intersection. You may also see drivers who are looking at street signs, maps, and house numbers. These drivers may not be paying attention to you.

**Slow Drivers.** Motorists who fail to maintain normal speed are hazards. Seeing slow moving

vehicles early can prevent an accident. Some vehicles by their nature are slow and seeing them is a hazard clue (mopeds, farm machinery, construction machinery, tractors, etc.). Some of these will have the “slow moving vehicle” symbol to warn you. This is a red triangle with an orange center. A vehicle displaying this sign may not be operated faster than 25 mph.



Drivers signaling a turn may slow more than expected or even stop. If making a tight turn into an alley or driveway, the driver may go very slowly. If blocked by pedestrians or other vehicles, the driver may have to stop on the roadway. Vehicles turning left may have to stop for oncoming vehicles.

**Drivers in a Hurry.** Drivers may feel your commercial vehicle is preventing them from getting where they want to go on time. Such drivers may pass you without a safe gap in the oncoming traffic, cutting too close in front of you. Drivers entering the road may pull in front of you in order to avoid being stuck behind you, causing you to brake.

**Impaired Drivers.** Drivers who are sleepy, have had too much to drink, are on drugs, or who are ill are hazards. Some clues to these drivers are:

- Weaving across the road or drifting from one side to another.
- Leaving the road (dropping right wheels onto the shoulder or bumping across a curb in a turn).
- Stopping at the wrong time (stopping at a green light or waiting too long at a stop).
- An open window in cold weather.
- Speeding up or slowing down suddenly.

Be alert for impaired drivers late at night.

**Driver Body Movement as a Clue.** Drivers look in the direction they are going to turn. You may sometimes get a clue from a driver’s head and body movements that a driver may be going to make a turn even though the turn signals

are not on. Drivers making over-the-shoulder checks may be going to change lanes. These clues are most easily seen in motorcyclists and bicyclists.

**Conflicts.** You are in conflict when you have to change speed and/or direction to avoid hitting someone. Conflicts occur at intersections where vehicles meet, at merges (such as freeway onramps), and where lane changes are needed. Other situations include slow moving or stalled traffic and accident scenes. Watch for other drivers who are in conflict because they are a hazard to you. When they react to this conflict, they may do something that will put them in conflict with you.

## Be Prepared For Hazards

You should always be looking for hazards—they may turn into emergencies. Look for hazards and plan a way out of any emergency. When you see a hazard, think about the emergencies that could develop and figure out what you would do. Always be prepared to take action based on your plans. In this way, you will be a prepared, defensive driver who will improve not only your own safety but the safety of all road users.

## Emergencies

Traffic emergencies occur when two vehicles are about to crash. Vehicle emergencies occur when tires, brakes, or other critical parts fail. Following the safety practices in this handbook can help prevent emergencies. But if an emergency does happen, your chances of avoiding a crash depend upon what action you take. Actions you can take are discussed below.

### Steering To Avoid A Crash

Stopping is not always the safest thing to do in an emergency. When you do not have enough room to stop, you may have to steer away from what is ahead. Remember, you can almost always turn to miss an obstacle more quickly than you can stop. However, top-heavy



vehicles and tractors with multiple trailers may flip over.

### **Keep Both Hands on the Steering Wheel.**

In order to turn quickly, you must grip the steering wheel firmly with both hands. Make a habit of having both hands on the wheel at all times. Then if there is an emergency, you will be prepared.

**How to Turn Quickly and Safely.** A quick turn can be made safely, if it is done the right way. Here are some points that safe drivers use:

- **Do not** apply the brakes while you are turning. It is very easy to lock your wheels while turning. If that happens, you will be skidding out of control before you know it.
- **Do not** turn any more than needed to clear whatever is in your way. The more sharply you turn, the greater the chances of a skid or rollover.
- Be prepared to “**countersteer**” (turn the wheel back in the other direction), once you have passed whatever was in your path. Unless you are prepared to countersteer, you will not be able to do it quickly enough. You should think of emergency steering and countersteering as two parts of one driving action.

**Where to Steer.** If an oncoming driver has drifted into your lane, a move to your right is best. If that driver realizes what has happened, the natural response will be to return to his or her own lane.

If something is blocking your path, the best thing to do will depend on the situation:

- If you have been using your mirrors, you will know which lane is empty and can be safely used.
- If the shoulder is clear, steering to the right may be best. No one is likely to be driving on the shoulder but someone may be passing you on the left. You will know if you have been using your mirrors.

- If you are blocked on both sides, a move to the right may be best. At least you will not force anyone into an opposing traffic lane and a possible head-on accident. If a stopped vehicle is in front of you, a lane change may be better than running directly into it.

**Leaving the Road.** In some emergencies, you may have to drive off the road. It may be less risky than facing an accident with another vehicle.

Most shoulders are strong enough to support the weight of a large vehicle and, therefore, offer an available escape route. Here are some guidelines if you do leave the road:

- **Avoid braking.** If possible, avoid using the brakes until your speed has dropped to about 20 mph. Then brake very gently to avoid skidding on a loose surface.
- **Keep one set of wheels on the pavement** if possible. This helps to maintain control.
- **Stay on the shoulder.** If the shoulder is clear, stay on it until your vehicle has come to a stop. Signal and check your mirrors before pulling back onto the road.

**Returning to the Road.** If you are forced to return to the road before you can stop, use the following procedure:

- Hold the wheel tightly and turn sharply enough to get right back on the road safely. Don't try to edge gradually back onto the road. If you do, your tires might grab unexpectedly and you could lose control.
- When both front tires are on the paved surface, countersteer immediately. The two turns should be made as a single “steer-countersteer” move.

### **Stopping Quickly And Safely**

If somebody suddenly pulls out in front of you, your natural response is to hit the brakes. This is a good response if you have enough distance to stop and you use the brakes correctly.

You should brake in a way that will keep your vehicle in a straight line and allow you to turn if it becomes necessary. You can use the “controlled braking” method or the “stab braking” method.

**Controlled braking.** With this method, apply the brakes as hard as you can *without* locking the wheels and keep steering wheel movements very small. If you need to make a larger steering adjustment or if the wheels lock, release the brakes. Reapply the brakes as soon as you can.

**Stab braking.** (Only on vehicles without antilock brake systems.) With this method, you should apply your brakes all the way and release the brakes when the wheels lock up. Then, as soon as the wheels start rolling, apply the brakes fully again. (It can take up to one second for the wheels to start rolling after you release the brakes. If you reapply the brakes before the wheels start rolling, the vehicle will not straighten out.)

**Do Not Slam on the Brakes.** Emergency braking does not mean pushing down on the brake pedal as hard as you can. That will only keep the wheels locked up and cause a skid. If the wheels are skidding, you cannot control the vehicle.

**NOTE:** If you drive a vehicle with antilock brakes, you should read and follow the directions found in the owner’s manual for stopping quickly.

## Brake Failure

Brakes kept in good condition rarely fail. Most hydraulic brake failures occur for one of two reasons: (Air brakes are discussed in Section 5.)

- Loss of hydraulic pressure.
- Brake fade on long hills.

**Loss of Hydraulic Pressure.** When the system will not build up pressure, the brake pedal will feel spongy or go to the floor. Here are some things you can do:

- **Downshift.** Put the vehicle into a lower gear to help to slow the vehicle.
- **Pump the brakes.** Sometimes pumping brakes will generate enough hydraulic pressure to stop the vehicle.
- **Use the parking brake.** The parking or emergency brake is separate from the hydraulic brake system and can be used to slow the vehicle. However, be sure to press the release button or pull the release lever *at the same time* you use the emergency brake so you can adjust the brake pressure and keep the wheels from locking up.
- **Find an escape route.** While slowing the vehicle, look for an escape route such as an open field, side street, or escape ramp. Turning uphill is a good way to slow and stop the vehicle. Keep the vehicle from rolling backward after you stop. Put it in low gear, apply the parking brake, and if necessary roll back into some obstacle that will stop the vehicle.

**Brake Failure on Downgrades.** Slow down and brake properly to prevent brake failure on long downgrades. Once the brakes have failed, however, you are going to have to look outside your vehicle for something to stop it.

Your best hope is an escape ramp. If there is one, there will be signs telling you about it. *Use it.* Ramps are usually located a few miles from the top of the downgrade. Some escape ramps use soft gravel that resists the motion of the vehicle and brings it to a stop. Others turn uphill, using the hill to stop the vehicle and soft gravel to hold it in place.

Any driver who loses brakes going downhill should use an escape ramp if it’s available. If you don’t use it, your chances of having a serious accident may be much greater.

If no escape ramp is available, take the least hazardous escape route you can such as an open field,

<p style="text-align: center;">RUNAWAY TRUCK RAMP 1 MILE</p>
--

or a side road that flattens out or turns uphill. Make the move as soon as you know your brakes do not work. The longer you wait, the faster the vehicle will be going and the harder it will be to stop.

## Tire Failure

There are four important things that safe drivers do to safely handle a tire failure:

- Know that a tire has failed.
- Hold the steering wheel firmly.
- Stay off the brake.
- After stopping, check all the tires.

**Recognize Tire Failure.** Knowing quickly that you have a tire failure gives you more time to react. The major signs of tire failure are:

- **Sound.** The loud “bang” of a blowout is an easily recognized sign. Because it can take a few seconds for the vehicle to react, you might think it was some other vehicle. Any time you hear a tire blow, to be safe, assume it is yours.
- **Vibration.** If the vehicle thumps or vibrates heavily, it may be a sign that one of the tires has gone flat. With a rear tire, that may be the only sign you get.
- **Feel.** If the steering feels “heavy,” it is probably a sign that one of the front tires has failed. Sometimes, failure of a rear tire will cause the vehicle to slide back and forth or “fishtail.” However, dual rear tires usually prevent this feeling.

Any of these signs is a warning of possible tire failure. You should do the following things.

- **Hold the steering wheel firmly.** If a front tire fails, it can twist the steering wheel out of your hands. The only way to prevent this is to have a firm grip on the steering wheel with both hands at all times.
- **Stay off the brakes.** It is natural to want to brake in an emergency. However, do not slam on the brakes. Hard braking when a tire has failed could cause loss

of control. Once you have control of the vehicle, slow down and brake very gently. Then pull off the road and stop.

- **Check all the tires.** After you have come to a stop, check all the other tires. Do this even if the vehicle seems to be handling all right. If one of your dual tires goes, the only way you may know it is by looking at it.

## Skid Control/Recovery

A skid happens whenever the tires lose their grip on the road. This can be caused by:

- **Overbraking.** Braking too hard and locking up the wheels. Skids also can occur if you use the speed retarder when the road is slippery.
- **Oversteering.** Turning the wheels more sharply than the vehicle can turn.
- **Overacceleration.** Supplying too much power to the drive wheels, causing them to spin.
- **Driving too fast.** Most serious skids result from driving too fast for road conditions.

Drivers who adjust their driving to road conditions do not overaccelerate and do not have to overbrake or oversteer.

## Rear Or Drive Wheel Skids

By far the most common skid is one in which the rear wheels lose traction through excessive braking or acceleration. Skids caused by acceleration usually happen on ice or snow. They can be easily stopped by taking your foot off the accelerator. (If it is very slippery, push the clutch in. Otherwise, the engine can keep the wheels from rolling freely and regaining traction.)

Rear wheel braking skids occur when the rear drive wheels lock. Locked wheels have less traction than rolling wheels, so the rear wheels usually slide sideways in an attempt to “catch up” with the front wheels. In a bus or straight

truck, the vehicle will slide sideways in a “spin out.” With vehicles towing trailers, a drive wheel skid can let the trailer push the towing vehicle sideways, causing a sudden jackknife. (Figure 2-10)

## Drive Wheel Skids

**Stop Braking.** This will let the rear wheels roll again and keep them from sliding any further. If on ice, push in the clutch to let the wheels turn freely.

**Turn Quickly.** When a vehicle begins to slide sideways, quickly turn the wheel in the direction you want the vehicle to go.

**Countersteer.** As a vehicle turns back on course, it has a tendency to keep right on turning. Unless you turn the steering wheel quickly the other way, you may find yourself skidding in the opposite direction.

Learning to stay off the brake, turning the steering wheel quickly, pushing in the clutch, and countersteering in a skid takes a lot of practice. The only place to get this practice is on a large driving range or “skid pad.”

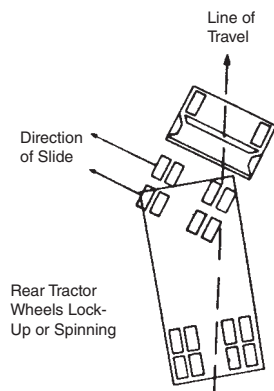

Figure 2-10

## Front Wheel Skids

Most front-wheel skids are caused by driving too fast for conditions. Other causes are: lack of tread on the front tires, and cargo loaded so that not enough weight is on the front axle. In a front-wheel skid, the front end tends to go in a straight line regardless of how much you turn the steering wheel. On a very slippery surface, you may not be able to steer around a curve or turn.

When a front-wheel skid occurs, the only way to stop the skid is to let the vehicle slow down. Stop turning and/or braking so hard. Stop the vehicle as quickly as possible.

## Accident Procedures

When you are in an accident and not seriously hurt, you need to act to prevent further damage or injury. The basic steps to be taken at any accident are:

- Protect the area.
- Notify the authorities.
- Care for the injured.
- Collect required information.
- Report the accident.

## Protect The Area

The first thing to do at an accident scene is to keep another one from happening at the same spot. To protect the accident area:

- Try to get your vehicle to the side of the road, if it is involved in the accident. This will help prevent another accident and allow traffic to move.
- Park away from the accident, if you are stopping to help. The area immediately around the accident scene will be needed for emergency vehicles.
- Turn on your 4-way flashers.
- Set out reflective triangles to warn other traffic. Make sure they can be seen by other drivers in time for them to avoid the accident.

## Notify Authorities

If you have a CB radio, put out a call over the emergency channel before you leave your vehicle or if you have a cellular phone, call 9-1-1. If you do not have a CB or a cellular phone, wait until after the accident scene has been properly protected, then phone or send someone to phone for the police or CHP. Try to determine where you are so you can give the exact location.

## Care For The Injured

If a qualified person is at the scene and helping the injured, stay out of the way unless you are asked to assist. Otherwise, do the best you can to help any injured parties. Here are some simple steps to follow in giving assistance:

- Do not move a severely injured person unless the danger of fire or passing traffic makes it necessary.
- Stop heavy bleeding by applying direct pressure to the wound.
- Keep the injured person warm.

## Gather Information

If you were involved in the accident, you will have to file an accident report. Collect the following information for the report.

- Names, addresses, and driver license numbers of other drivers involved in the accident.
- License plate numbers and types of vehicles involved in the accident.
- Names and addresses of the owners of other vehicles (if different from the drivers).
- A description of the damage to other vehicles or to property.
- Name and address of anyone who was injured or involved in the accident.
- Name, badge number, and agency of any peace officer investigating the accident.
- Names and addresses of witnesses.
- Exact location of the accident.
- Direction of travel of the vehicles involved.

## Fires

Vehicle fires can cause damage and injury. Learn the causes of fires and how to prevent them. Know what to do to extinguish fires.

### Fire Causes

The following are some causes of vehicle fires:

- **After accidents.** Spilled fuel, improper use of flares.
- **Tires.** Underinflated tires or duals that touch.
- **Electrical system.** Short circuits due to damaged insulation, loose connections.
- **Fuel.** Driver smoking, improper fueling, loose fuel connections.
- **Cargo.** Flammable cargo which is improperly sealed or loaded; poor ventilation.

### Fire Prevention

Pay attention to the following:

- **Pre-trip inspection.** Make a complete inspection of the electrical, fuel and exhaust systems, tires, and cargo. Be sure to check that the fire extinguisher is charged.
- **En route inspection.** Check the tires, wheels, and truck body for signs of heat whenever you stop during a trip.
- **Follow safe procedures.** Follow correct safety procedures for fueling the vehicle, using brakes, handling flares, and other activities that can cause a fire.
- **Monitoring.** Check the instruments and gauges often for signs of overheating and use the mirrors to look for signs of smoke from tires or the vehicle.
- **Caution.** Use care in handling anything flammable.

### Fire Fighting

Knowing how to fight fires is important. Fires have been made worse by drivers who did not know what to do. Know how the fire extinguisher works. Study the instructions printed on the extinguisher before you need it. Here are some procedures to follow in case of fire:

- **Pull off the road.**
  - park in an open area away from buildings, trees, brush, other vehicles, or anything that might catch fire.

- do not pull into a service station!
- notify emergency services of the problem and your location.
- **Keep the fire from spreading.** Before you try to put out the fire, make sure it doesn't spread any further.
- with an **engine** fire, turn off the engine as soon as you can. Do not open the hood if you can avoid it. Aim extinguishers through louvers, radiator, or from the underside of the vehicle.
- for a **cargo** fire in a van or box trailer, keep the doors shut, especially if your cargo contains hazardous materials. Opening the van door supplies the fire with oxygen and can cause it to burn very fast.
- **Use the correct fire extinguisher.**
- the B:C type fire extinguisher is designed to work on electrical fires and burning liquids. The A:B:C type is designed to work on burning wood, paper, and cloth.
- water can be used on wood, paper, or cloth, but do not use water on an electrical fire (you could get shocked) or a gasoline fire (it will just spread the flames).
- a burning tire must be cooled. Lots of water may be required.
- if you are not sure what to use, especially on a hazardous materials fire, wait for qualified fire fighters.
- **Extinguish the fire.** Here are some rules to follow in putting out a fire. (Refer to 13 CCR §1242 for additional information):
- when using the extinguisher, stay as far away from the fire as possible.
- aim at the source or base of the fire, not in the flames.
- position yourself upwind. Let the wind carry the spray to the fire rather than carrying the flames to you.
- continue until whatever was burning has been cooled. Absence of smoke or flame does not mean the fire is completely out or cannot restart.

- only try to extinguish the fire if you know what you are doing and it is safe to do so.

## Staying Alert And Fit To Drive

Driving a vehicle for long hours is tiring. However, there are things that good drivers do to help stay alert and safe.

**Get enough sleep.** Leaving on a long trip when you are already tired is dangerous. If you have a long trip scheduled, make sure that you get enough sleep before you go.

**Schedule trips safely.** Your body gets used to sleeping during certain hours. If you are driving during those hours, you will be less alert. Try to schedule trips for the hours you are normally awake. Many heavy motor vehicle accidents occur between midnight and 6:00 AM. Tired drivers can easily fall asleep at these times, especially if they don't regularly drive during those hours. Trying to push on and finish a long trip at these times can be very dangerous.

**Avoid medication.** Many medicines can make you sleepy. Those that do have a label warning against operating vehicles or machinery. The most common medicine of this type is an ordinary cold pill. If you have to drive with a cold, you are better off suffering from the cold than from the effects of the medicine.

**Keep cool.** A hot, poorly ventilated cab can make you sleepy. Keep the window or vent cracked or use the air conditioner if you have one.

**Take breaks.** Short breaks can keep you alert. But the time to take them is before you feel really drowsy or tired. Stop often. Walk around and inspect your vehicle. It can help to do some physical exercises.

When you are sleepy, trying to “push on” is far more dangerous than most drivers think. It is a major cause of fatal crashes. Here are some important rules to follow:

- **Stop to sleep.** When your body needs sleep, sleep is the only thing that will work. If you have to make a stop anyway, make it whenever you feel the first signs of sleepiness, even if it is earlier than you planned. By getting up a little earlier the next day, you can keep on schedule without the danger of driving while you are not alert.
- **Take a nap.** If you can't stop for the night, at least pull off the road at a safe place, such as a rest area or truck stop, and take a nap. A nap as short as a half hour will do more to overcome fatigue than a half hour coffee stop.
- **Avoid drugs.** There are no drugs that can overcome being tired. While they may keep you awake for a while, they will not make you alert. And eventually, you will be even more tired than if you had not taken them at all. Sleep is the only thing that can safely overcome fatigue.

### Alcohol And Driving

Drinking alcohol and then driving is a very serious problem. People who drink alcohol are involved in traffic crashes resulting in thousands of deaths every year. You should know:

- How alcohol works in the human body.
- How alcohol affects driving.
- Laws regarding drinking, drugs, and driving.
- Legal, financial, and safety risks of drinking and driving.

You may NEVER drink while on duty nor consume any intoxicating beverage, *regardless of its alcoholic content*, within 4 hours before going on duty.

Remember—it is illegal to drive a commercial motor vehicle with a blood alcohol concentration (BAC) that is 0.04% or greater and doing so will result in an immediate administrative driver licensing sanction (Admin Per Se). (VC §§23152[d] & 13353.2 [3]) However, a BAC below 0.04% does not mean that it is safe or legal to drive.

### The Truth About Alcohol

There are many dangerous ideas about the use of alcohol. The driver who believes in these wrong ideas will be more likely to get into trouble. Look at the chart below for some examples.

### What Is Considered A Drink?

It is the alcohol in drinks that affects our performance. It does not make any difference

FALSE NOTION	TRUE STATEMENT
Alcohol increases your ability to drive.	Alcohol is a drug that will make you less alert and reduce your ability to drive safely.
Some people can drink a lot and not be affected by it.	Everyone who drinks is affected by alcohol.
If you eat a lot first, you will not get drunk.	Food will slow down the effects of alcohol but will not prevent them.
Coffee and a little fresh air will help a drinker sober up.	Only time will help a drinker sober up—other methods just do not work.
Stick with beer—it is not as strong as wine or whiskey.	A few beers are the same as a few glasses of wine or a few shots of whiskey.

whether that alcohol comes from a “couple of beers” or from two glasses of wine or two shots of hard liquor.

All of the following drinks contain the same amount of alcohol:

- A 12-ounce glass of 5% beer.
- A 5-ounce glass of 12% wine.
- A 1-1/2 ounce shot of 80 proof liquor.

**How alcohol works.** Alcohol goes directly from the stomach into the blood stream. A drinker can control the amount of alcohol which he or she takes in, by having fewer drinks or none. However, the drinker cannot control how fast the body gets rid of alcohol. If you have drinks faster than your body can get rid of them, you will have more alcohol in your body and your driving will be more affected. The amount of alcohol in your body is commonly measured by the Blood Alcohol Concentration (BAC).

**What Determines BAC.** BAC is determined by the amount of alcohol you drink (more alcohol means higher BAC), how fast you drink (faster drinking means higher BAC), and your weight (a small person does not have to drink as much to reach the same BAC as a larger person).

**Alcohol and the Brain.** Alcohol affects more and more of the brain as BAC builds up. The first part of the brain affected controls judgment and self-control. One of the bad things about this is it can keep drinkers from knowing they are getting drunk. And, of course, good judgment and self-control are absolutely necessary for safe driving.

As BAC continues to build, muscle control, vision, and coordination are affected more and more. Eventually, a person will pass out.

## How Alcohol Affects Driving

All drivers are affected by drinking alcohol. Alcohol affects judgment, vision, coordination, and reaction time. It causes serious driving errors, such as:

- Driving too quickly or too slowly.
- Driving in the wrong lane.
- Running over the curb.
- Weaving.
- Driving between lanes.
- Quick, jerky starts.
- Not signaling, failing to use lights.
- Running stop signs and red lights.
- Improper passing.
- Being overly cautious.

These effects increase the chances of an accident. You also could lose your driving privilege. Accident statistics show that the chance of an accident is much greater for drivers who have been drinking than for drivers who have not.

## Other Drugs

Besides alcohol, other legal and illegal drugs are being used more often. Laws prohibit possession or use of many drugs while on duty. They prohibit driving while under the influence of any “controlled substance” such as amphetamines (including “pep pills” and “bennies”), narcotics, or any other substance which can make the driver unsafe. This could include a variety of prescription and over-the-counter drugs (cold or allergy medicines) which may make the driver drowsy or otherwise affect safe driving ability. However, possession and use of any medication given to a driver by a physician is permitted if the physician advises the driver that the medicine **will not** affect safe driving ability.

Pay attention to warning labels of legitimate drugs and medicines and to your physician’s orders regarding possible side effects. Stay away from illegal drugs. Do not use any substance that hides fatigue—the only cure for fatigue is rest. Alcohol can make the effects of the drugs much worse. The safest rule is do not mix drugs with driving.

Use of drugs can lead to traffic crashes resulting in death, injury, and property damage. Furthermore, it can lead to arrest, fines, and



jail sentences. It may also mean the end of a person's driving career.

## Illness

Once in awhile, you may become so ill or fatigued that you cannot operate a motor vehicle safely. If this happens, you must not drive. In case of an emergency, drive only to the nearest place where you can safely stop.

## HazMat Rules For All Commercial Drivers

All drivers should know something about hazardous materials (HazMat) and wastes. You must be able to recognize hazardous cargo and you must know whether you can transport it without having a HazMat endorsement on your CDL.

To get the HazMat endorsement, you must pass a written test based on the information in Section 9 of this handbook. You also will need a tank vehicle endorsement if you transport hazardous products in a cargo tank.

If you apply for an original or renewal HazMat endorsement, you must undergo a Transportation Security Administration (TSA) federal security threat assessment (background records check). You start the TSA background records check after you apply for your CDL at DMV, successfully complete all appropriate law tests, and submit a valid medical form. You must submit fingerprints, a fee, and any additional required information to one of TSA's designated agents. You must also provide the TSA agent with a copy of your CDL permit and one of the following identification documents:

- A California DL/ID card
- An out-of-state DL
- Your CDL permit accompanied by a DMV photo receipt

For a list of TSA agent sites, go online at [www.hazprints.com](http://www.hazprints.com) or call 1-877-429-7746.

## What Are The Rules?

The Federal Hazardous Materials Table lists materials that are hazardous. They can be a risk to health, safety, and property during transportation. You must follow the many rules about transporting them. The intent of hazardous materials rules and regulations is to:

- Contain the product.
- Communicate the risk.
- Ensure safe drivers and equipment.

**To contain the product.** Many hazardous products can injure or kill on contact. In order to protect drivers and others from contact, the rules tell shippers how to package safely. Similar rules tell drivers how to load, transport, and unload. These are containment rules.

**To communicate the risk.** The shipper uses a shipping paper and package labels to warn dockworkers and drivers of the risk and special handling needs. Shipping orders, bills of lading, and manifests are all examples of shipping papers.

There are 9 different hazard classes. A material's hazard class reflects the risks associated with it. The hazard classes are shown on page 91.

Shippers write the proper shipping name and hazard class or division code in the item description of the shipping paper. Hazard class information will also be shown on four-inch diamond shaped labels on the containers of hazardous materials. If the diamond label will not fit on the container, shippers will put the label on a tag or in some instances, reduce the size. For example, compressed gas cylinders that will not hold a label will have tags or decals. Package markings may convey proper shipping names, United Nations identification numbers, and special handling information (e.g., loading orientation arrows for liquids).

After an accident or hazardous materials leak, the driver may be unable to speak when help arrives. Fire fighters and police must know the hazards involved in order to prevent more damage or injury. The driver's life, and the lives of others, may depend on quickly finding the shipping papers for hazardous cargo. For that reason, you must tab shipping papers related to hazardous materials or wastes, or keep them on top of other shipping papers. You must also keep shipping papers in a pouch on the driver's door or in clear view within reach or on the driver's seat when out of the cab.

Drivers must use placards to warn others of their hazardous cargo. Placards are signs placed on the outside of a vehicle to show the hazard class(es) of products on board. Each is turned upright on a point, in a diamond shape. The person who does the loading must place the placards on the front, rear, and both sides of the vehicle. (See page 92.)

Not all vehicles transporting hazardous materials or wastes need to have placards. The rules about placards are given in Section 9 of this handbook.

**To ensure safe drivers and equipment.** The rules require all drivers of placarded or marked vehicles (VC §27903) to have a commercial driver license with the HazMat endorsement. You must learn how to safely load and transport hazardous materials or wastes.

Drivers who need the HazMat endorsement must learn the placarding rules. If you do not know if your load requires placards, ask your employer or shipper. **Never drive a vehicle needing placards unless you have the HazMat endorsement on your CDL.** To do so is a crime. If stopped, you will be cited and you will not be allowed to drive your vehicle further. It will cost you time and money. A failure to placard when needed will risk your life and others if you have an accident. Emergency help will not know of your hazardous cargo.

Hazardous materials/wastes drivers must also know which products can be loaded together, and which cannot. These rules are also in Section 9. Before loading a vehicle with more than one type of product, you must know if it is safe to load them together.

## Section 3: Transporting Cargo

This section is for all commercial drivers

This section is about cargo safety. You must pass a written test on cargo safety to get a commercial driver license.

If you load or secure cargo incorrectly, it can be a danger to others and yourself. Loose cargo that falls off a vehicle can cause traffic problems and others could be hurt or killed. Loose cargo can hurt or kill you during a quick stop or accident. Your vehicle can be damaged by an overload. Steering can be affected by an improperly loaded vehicle making it more difficult to control.

Whether or not you load and secure the cargo yourself, you are responsible for:

- Inspecting cargo.
- Recognizing overloads and poorly balanced weight.
- Ensuring that the cargo is securely tied down and covered, if applicable.

If you intend to carry hazardous materials or wastes that requires placards or markings on your vehicle, you will also need a HAZMAT endorsement.

### Inspecting Cargo

As part of your pre-trip inspection, check for overloads, poorly balanced weight, and cargo that is not secured correctly.

Inspect the cargo and its securing devices again within 25 miles after beginning a trip. Make any adjustments needed. Check the cargo and securing devices as often as necessary during a trip to keep the load secure. Inspect again:

- After you have driven for 3 hours or 150 miles, whichever comes first.
- After every break you take during driving.

Federal, state, and local regulations of weight, securement, cover, and truck routes vary greatly from place to place. Know the regulations where you will be driving.

### Cargo Weight And Balance

You are responsible for making sure that the vehicle is not overloaded. Here are some definitions you should know:

**Gross vehicle weight (GVW).** The total weight of a single vehicle including its load.

**Gross combination weight (GCW).** The total weight of a combination of vehicles including the load.

**Gross vehicle weight rating (GVWR).** The maximum weight rating specified by the manufacturer for a single vehicle including its load.

**Gross combination weight rating (GCWR).** The total GVWRs for the power unit and any towed vehicles. (This is not the same as the GVWR specified by a manufacturer for the towing capacity of a vehicle.)

**Axle weight.** The weight on the ground at one or more sets of axles.

**Tire load.** The maximum safe weight rating a tire can carry at a specified pressure. This rating is stated on the side of each tire.

**Suspension systems.** Suspension systems have a manufacturer's weight capacity rating.

**Coupling device capacity.** Coupling devices are rated for the maximum weight they can pull and/or carry.

## Legal Weight Limits

Weights must be kept within legal limits. States have maximums for GVWs, GCWs, and axle weights. Often, maximum axle weights are set by a bridge formula which permits less axle weight for axles that are closer together. This is to prevent overloading bridges and roadways.

Overloading can have bad effects on steering, braking, and speed control. Overloaded trucks have to go very slowly on upgrades. Worse, they may gain too much speed on downgrades. Stopping distance increases. Brakes can fail when forced to work too hard.

During bad weather or in mountains, operating at legal maximum weights may not be safe. Take this into account before driving.

## Avoid Top-Heavy Loads

The height of the vehicle's center of gravity is very important for safe handling. A high center of gravity (cargo piled up high, or heavy cargo on top) means you are more likely to roll, especially on curves or if you have to swerve to avoid a hazard. It is very important to distribute cargo so the center of gravity is as low as possible. Load the heaviest parts of the cargo first or on the bottom.

## Balance Cargo Weight

Poor weight balance can make vehicle handling unsafe. Too much weight on the steering axle can cause hard steering and can damage the steering

axle and tires. Underloaded front axles (caused by loading weight too far to the rear) can make the steering axle weight too light to steer safely. Too little weight on the driving axles can cause poor traction, so that during bad weather, the truck may not be able to keep going. Weight that is loaded with a high center of gravity has a greater chance of rollover. On flatbed vehicles, there is also a greater chance that the load will shift to the side or fall off. Figure 3-1 shows examples of the right and wrong way to balance cargo weight.

## Securing Cargo

Blocking is used in the front, back, and/or sides of a piece of cargo to keep it from sliding. Blocking is shaped to fit snugly against cargo. It is secured to the cargo deck to prevent cargo movement. Bracing is also used to prevent movement of cargo. Bracing goes from the upper part of the cargo to the floor and/or walls of the cargo compartment.

## Tiedowns

On flatbed trailers or trailers without sides, cargo must be secured to keep it from shifting and falling off. In closed vans, tiedowns can also be important to prevent cargo shifting that may affect the handling of the vehicle. Tiedowns must be of the correct type and strength. The combined strength of all cargo tiedowns must be strong enough to lift one and one half times the weight of the piece of cargo tied down. Proper tiedown

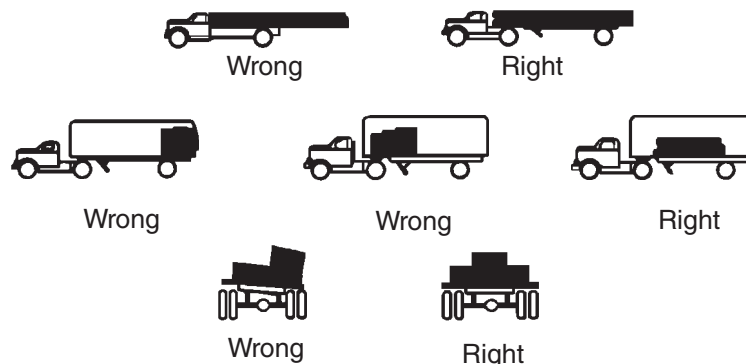

Figure 3-1 Balancing Cargo Weight

equipment must be used, including ropes, straps, chains, and tensioning devices (winches, ratchets, cinching components). Tiedowns must be attached to the vehicle correctly (hook, bolt, rails, rings).

Cargo should have at least one tiedown for each 10 feet of cargo. Make sure you have enough tiedowns to meet this need. No matter how small the cargo, it should have at least two tiedowns holding it.

Rules governing the loading and securement of logs, dressed lumber, metal coils, paper rolls, concrete pipe, intermodal containers, automobiles, heavy vehicles, flattened or crushed vehicles, Roll-On/Roll-Off containers, and large boulders are contained in the *Code of Federal Regulations*, Title 49, §393.

## Covering Cargo

There are two basic reasons for covering cargo: (1) to protect people from spilled cargo, and (2) to protect the cargo from weather. Spill protection is a safety requirement in many states. Be familiar with the laws in the states where you will be driving.

You should look at your cargo covers in the mirrors often while driving. A flapping cover can tear loose, uncovering the cargo and possibly block your view or someone else's.

**Spilling Loads and Damage to Highway.** (VC §§23114 and 23115) It is against the law to operate on the highway a vehicle which is improperly covered, constructed, or loaded so that any part of its contents or load spills, drops, leaks, blows, sifts, or in any other way escapes from the vehicle. (**Exception:** clear water or feathers from live birds.)

Any vehicle transporting garbage, trash, rubbish, ashes, etc., must have the load covered to prevent any part of the load from spilling on to the highway. Aggregate material must be carried in the cargo area of the vehicle and be six inches below the upper edge. The cargo area must not

have any holes, cracks, or openings which could allow the material to escape. The vehicle used to transport aggregate material must be equipped with seals on any openings used to empty the load, splash flaps behind every tire or set of tires, and fenders. Other requirements are listed in VC §23114. This does not apply to vehicles carrying wet waste fruit or vegetable matter, or waste from food processing plants.

Any person who willfully or negligently damages any street or highway is liable for the cost of repairing the road or any sign, signal, guard rail, or other facility that is damaged. The liability may include the cost of removing debris from the roadway.

## Header Boards

Front end header boards (“headache racks”) protect you from your cargo in case of an accident or emergency stop. Be sure the front end structure is in good condition. The front end structure should block the forward movement of any cargo you carry.

You cannot inspect sealed loads, but you should check that you do not exceed gross weight and axle weight limits.

## Sealed And Containerized Loads

Containerized loads generally are used when freight is carried part way by rail or ship. Delivery by truck occurs at the beginning and/or end of the journey. Some containers have their own tiedown devices or locks that attach directly to a special frame. Other containers (following the regulations established by the CHP) have to be loaded onto flatbed trailers. They are secured with tiedowns just like any other large cargo.

## Handling Other Cargo

**Dry bulk tanks** require special care because they often have a high center of gravity and the load can shift. Be extremely cautious going around curves and making sharp turns.

## Hanging Meat

**Hanging meat** (suspended in a refrigerated truck) can be a very unstable load with a high center of gravity. Particular caution is needed on sharp curves such as offramps and onramps. Go slowly.

## Livestock

**Livestock** can move around in a trailer. This shifts the center of gravity and makes rollover more likely. With less than a full load, use false bulkheads to keep livestock bunched together. Even when bunched, special care is necessary because livestock can lean on curves.

## Oversized Loads

**Overlength, overwidth, and/or overweight loads** require Caltrans transit permits. Driving is usually limited to certain times of the day. Special equipment may be necessary such as “wide load” signs, flashing lights, flags, etc. Such loads may require a police escort or pilot vehicles bearing warning signs and/or flashing lights. These special loads require special driving care.

## Special Markings Needed

Any vehicle and load over 80 inches must, in addition to required vehicle lighting, show an amber combination clearance and side-marker lamp on the side of the load projection at the front and show a red combination clearance and side-marker lamp on the side of the projection at the rear.

Alternatively, if the overwidth of the projection does not extend more than three feet from front to rear at least one amber combination clearance lamp must be visible front, side, and rear at the extreme width, if the projection is near the front of the vehicle. If the projection is near the rear, at least one red combination side clearance lamp must be displayed. (VC §25100)

## Projecting Loads

**Lights (or flags) on projecting loads.** When the load on any vehicle extends four feet or more beyond the rear of the body, a solid red or fluorescent orange flag at least 12 inches square must be placed at the extreme end of the load. If the vehicle is operated during darkness, there must be two lighted red lights at the end of the load visible at a distance of 500 feet to the side and rear of the vehicle. (VC §24604)

A load extending one foot or more to the left on any vehicle must have an amber light on the extreme left side of the load. It must be visible at least 300 feet to the front and rear during darkness. If the load extends more than 120 inches, there must be an amber lamp at the front and a red lamp at the rear visible at least 300 feet.

If the vehicle is wider than 102 inches, a red or fluorescent flag not less than 12 inches square must be displayed at left front and left rear during daylight. (VC §25104)

## Piggyback Trailers

When any trailer is loaded upon another vehicle (piggyback) to be moved on any highway, the trailer must be securely bound to the vehicle to prevent the trailer from shifting, toppling over, or becoming unstable.

## Section 4: Transporting Passengers

This section is for drivers who transport passengers

This section contains general knowledge and safe driving practices for passenger vehicle drivers. You must take a test on the information contained in this section to get an endorsement on your CDL. Passenger vehicle drivers have special responsibilities. They are not only responsible for the condition and safe operation of their vehicle, but also for the safety of their passengers.

This section does not contain information on air brakes. You must read Section 5 of this handbook for that information.

### *Passenger Vehicle Endorsement Needed*

You must have a passenger vehicle endorsement for a passenger transportation vehicle which includes, but is not limited to, a bus, farm labor vehicle, or general public paratransit vehicle when the vehicle is designed, used, or maintained to carry more than 10 passengers including the driver, for hire or for profit, or by any nonprofit organization or group.

If you take a driving test in a van designed, used, or maintained to carry 15 persons or less including the driver, you will be restricted to driving a small-size bus.

## Vehicle Inspections

**Safety.** Safety is the most important and obvious reason to inspect your vehicle. Also, federal and state laws require inspection by the driver. Federal and state inspectors also inspect commercial vehicles. An unsafe vehicle can be put *out of service* until the driver or owner has it repaired. Do not risk your life or the lives of your passengers in an unsafe vehicle.

Many drivers work for companies who have maintenance mechanics responsible for much of the detailed checks outlined in this section.

However, as a driver you must still be able to check for and recognize many of the signs of unsafe operating conditions. The driver must also inspect the emergency equipment and make sure it is in place and ready for use.

### Types of Inspections

**Pre-trip Inspection.** Do a pre-trip inspection before each trip to find problems that could cause an accident or a breakdown. A pre-trip inspection should be routinely done before operating the vehicle.

**During a trip** you should:

- Watch gauges for signs of trouble.
- Use your senses to check for problems (look, listen, smell, feel).
- Check critical items when you stop.
  - tires, wheels, and rims
  - brakes
  - lights

**After-Trip Inspection and Report.** Inspect your transport vehicle at the end of the trip, day, or tour of duty. It may include filling out a *vehicle condition report* listing any problems you find.

If you work for an interstate carrier and you drive buses, you must complete a written inspection report for each bus driven. The report must specify each bus and list any defect that would affect safety or result in a breakdown. If there are no defects, the report should say so.

### What To Look For

**Tire Problems.** It is dangerous to drive with bad tires. Front tires must not be recapped, retreaded, or regrooved. Look for:

- Too much or too little air pressure.
- Tire wear. You need at least 4/32 inch tread depth in every major groove on front tires and 2/32 inch on other tires. No fabric should show through the tread or sidewall.
- Cuts or other damage.
- Tread separation.
- Dual tires that come in contact with each other or parts of the vehicle.
- Mismatched sizes.
- Radial and bias-ply tires used together.
- Cut or cracked valve stems.
- After a tire has been changed, stop a short while later and recheck the tightness of the wheel fasteners.

**Wheel and Rim Problems.** A damaged rim can cause a tire to lose pressure or come off. Look for:

- Rust around wheel fasteners—check tightness.
- Missing clamps, spacers, studs, or lugs.
- Mismatched, bent, or cracked lock rings.
- Signs of damage in wheels or rims that have had welding repairs.

**Suspension System Defects.** The suspension system supports the vehicle and its load and keeps the axles in place. Check for, if visible:

- Cracked or broken spring hangers, if so equipped.
- Missing or broken leaves in any leaf spring (if 1/4 or more are missing or broken or a main leaf spring is broken, the vehicle will be put out of service during a state or federal inspection. However, any defect could be dangerous).
- Leaking shock absorbers.
- Air suspension systems that are damaged and/or leaking (do not move with less than 80 p.s.i.)

**Exhaust System Defects.** A broken exhaust system can let poisonous fumes into the bus or other passenger transport vehicle. If visible, check for:

- Loose, broken, or missing exhaust pipes, mufflers, tailpipes, or vertical stacks.
- Loose, broken, or missing mounting brackets, clamps, or bolts.
- Exhaust system parts rubbing against fuel system parts, tires, electrical wiring, combustible parts, or other moving parts.
- Exhaust system parts that are leaking.
- Excessive smoke.

**Emergency Equipment.** Federal law requires that a bus carry:

- Spare electrical fuses (unless the vehicle has circuit breaker).
- Three red reflective triangles.
- Properly charged and rated fire extinguisher, if required.

### Inspection Method

See Section 10 for inspection information and guidelines. Memory aids are shown on pages 125 and 126. You may only use one of these when you take your CDL pre-trip test for your license at the DMV. The memory aid cannot include instructions on how to perform the pre-trip inspection. Also refer to Section 5 for Air Brake information.

### Emergency Exits

Check the emergency exits for ease of operation, correct markings and to ensure that any required buzzers or devices work properly.

Never drive with an open emergency exit door or window. The “emergency exit” sign on an emergency door must be clearly visible. If there is a red emergency door light, it must work. Turn it on at night or any other time you use your outside lights.



## Bus Interior

Always check the interior of the bus before driving to ensure rider safety. Aisles and stairwells must always be clear. The following parts of your bus must be in safe working condition:

- Each handhold and railing.
- Floor covering.
- Signaling devices, including the rest room emergency buzzer (if the bus has a rest room).
- Emergency exit handles.

The seats must be safe for riders and must be securely fastened to the bus. The number of passengers (excluding infants in arms) must not exceed the number of safe and adequate seating spaces, unless standing in designated areas is allowed.

The driver's seat should have a seat belt. Ensure it works properly and remember to wear it. The law requires you to wear your seat belt.

In the passenger compartment of a farm labor vehicle, all cutting tools or tools with sharp edges shall be placed in covered container. All other tools, equipment, or materials carried in the passenger compartment shall be secured to the body of the vehicle. The driver and all passengers must wear seat belts.

## Roof Hatches

You may lock some emergency roof hatches in a partly open position for fresh air. Do not leave them open as a regular practice. Keep in mind the bus' higher clearance while driving with them open.

## Loading And Unloading

Bus drivers need to consider passenger safety during loading and unloading. Always ensure your passengers are safely on the bus before closing the door(s) and pulling away. Allow passengers enough time to sit down or brace themselves before departing. Starting and

stopping should be as smooth as possible to avoid rider injury.

## Standee Lines

Buses designed to allow standing must have a two-inch line on the floor or some other means of showing riders where they cannot stand. This is called the standee line. All standing riders must stay behind it.

## At Your Destination

When you arrive at your destination or intermediate stops announce:

- The location,
- Reason for stopping,
- Next departure time, and
- Bus number.

Remind riders to take their carry-ons with them if they are getting off the bus. If the aisle is on a lower level than the seats, remind the riders to watch their step. It is best to tell them before coming to a complete stop.

Charter bus drivers should not allow riders on the bus until departure time. This will help prevent theft or vandalism of the bus.

## Baggage

Do not allow riders to leave carry-on baggage in a doorway or aisle. There should be nothing in the aisle that might trip riders. Secure baggage and freight in ways that avoid damage, and:

- Allow the driver to move freely and easily.
- Allow riders to exit by any window or door in an emergency.
- Protect riders from injury if carry-ons fall or shift.

## Hazardous Substances

Watch for cargo or baggage containing hazardous materials or wastes. Most hazardous materials or wastes cannot be carried on a bus.

The Federal Hazardous Materials Table shows which materials are hazardous. They pose a risk to health, safety, and property during transportation. Charts showing all the labels start on page 112. Watch for the diamond-shaped hazard labels. Do not transport any hazardous substances requiring placards unless you are sure the rules allow it and you have a HAZMAT endorsement on your CDL.

Buses may carry small arms ammunition labeled ORM-D, emergency hospital supplies and drugs. You can carry small amounts of some other hazardous materials if the shipper cannot send them any other way. Buses must **never** carry:

- Division 2.3 poisons, liquid Division 6.1 poisons, tear gas, irritating materials.
- More than 100 lbs. of solid Division 6.1 poisons.
- Explosives in the space occupied by people, except small arms ammunition.
- Labeled radioactive materials in the space occupied by people.
- More than 500 lbs. total of allowed hazardous materials, and no more than 100 lbs. of any one class.

Riders sometimes board a bus with an unlabeled hazardous material. They may not know it is unsafe. Do not allow riders to carry on hazards such as car batteries or gasoline. Oxygen

medically prescribed for, and in the possession of, a passenger and in a container designed for personal use is allowed.

Wheelchairs transported on buses (except school buses) must have brakes or other mechanical means of holding it still while it is raised or lowered on the wheelchair platform. Batteries must be spill resistant and securely attached to the wheelchair. Wheelchairs may not use flammable fuel. (School bus wheelchair regulations are in 13 CCR 1293.)

### Animals

Transporting animals is prohibited except for certified service, guide, or signal dogs used by physically challenged passengers. (CC 54.2)

### Driving Techniques

Stop at railroad crossings. Stop your bus between 15 and 50 feet before railroad crossings. Look and listen in both directions for trains. You should open your forward door if it improves your ability to see or hear an approaching train. After a train has passed and before crossing the tracks, be sure there is not another train coming in either direction on other tracks. You must not change gears while crossing the tracks, if your vehicle has a manual transmission.

Figure 4-1

⚡ - Official traffic control signal  
 ⚡ - Railroad crossing warning device

#### EXEMPT CROSSINGS

#### NOT EXEMPT

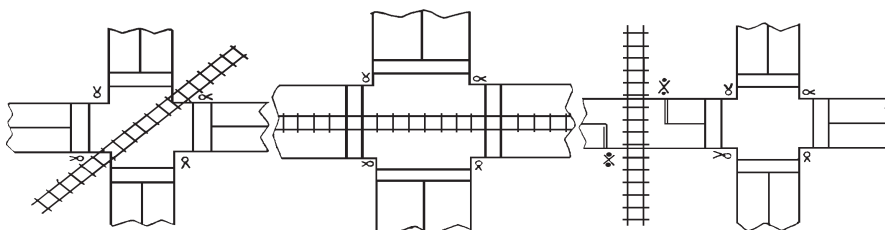

## Railroad Crossings

No stop needs to be made: (See Figure 4-1)

- At railroad tracks which run alongside and on the roadway within a business or residence district.
- Where a traffic officer or flagman is directing traffic.
- If the railroad track is within the intersection and the traffic control signal shows green.
- At railroad crossings marked “exempt crossing.”

## Draw Bridges

Stop at drawbridges that do not have a signal light or traffic control attendant. Stop at least 50 feet before the draw of the bridge. Look to see if the draw is completely closed before crossing. You do not need to stop, but must slow down when:

- There is a traffic light showing green.
- The bridge has an attendant or traffic officer that controls traffic whenever the bridge opens.

## Common Causes Of Bus Crashes

Crashes often happen at intersections. Use caution, even if a signal or stop sign controls other traffic. Remember the clearance your bus needs, and watch for poles and tree limbs at stops. Know the size of the gap your bus needs to accelerate and merge with traffic. Never assume other drivers will brake to give you room when you signal or start to pull out.

Crashes on curves result from excessive speed, often when rain or snow has made the road slippery. Every banked curve has a safe design speed. The design speed is often less than the posted speed for the curve. Although the posted speed is safe for smaller vehicles, it may be too high for many buses. With good traction, the bus may roll over; with poor traction, it will simply slide off the curve. Reduce speed for curves! If your bus leans toward the outside on a banked curve, you are driving too fast.

## Passenger Management

Passenger supervision is necessary while driving. Many charter and intercity carriers have passenger comfort and safety rules. Explaining the rules at the start of the trip will help to avoid trouble later.

While driving, scan the interior of your bus as well as the road ahead, to the sides and to the rear. You may have to remind riders about the rules or to keep arms and heads inside the bus.

Riders can stumble when getting on or off and when the bus starts or stops. Caution riders to watch their step when leaving the bus. Wait for them to sit down or brace themselves before starting. Starting and stopping should be as smooth as possible to avoid rider injury.

## Unruly Passengers

Occasionally, you may have a rider who is unruly or under the influence of alcohol and/or drugs. You must ensure this rider’s safety as well as that of others. Do not discharge a rider where it would be unsafe. It may be safer to unload a passenger at the next scheduled stop, or a well lighted area where there are other people.

## Miscellaneous Requirements

The nozzle of the fuel hose must be in contact with the intake of the fuel tank when refueling. No driver or motor carrier shall permit a vehicle to be fueled while:

- The engine is running.
- A radio on the bus is transmitting.
- The bus is close to any open flame or ignition source (including persons who are smoking).
- Passengers are aboard any bus (except one fueled by diesel in an open area or in a structure open at both ends).

### **Brake Door Interlock**

Urban mass transit coaches may have a brake and accelerator interlock system. The interlock applies the brakes and holds the throttle in idle position when the rear door is open. The interlock releases when you close the rear door. Do not use this safety feature in place of the parking brake when safety requires the use of the parking brake.

### **Prohibited Practices**

Do not engage in unnecessary conversation with passengers or any other distracting activity while driving.

Do not tow or push a disabled bus with riders aboard the vehicle, unless discharging the passengers would be unsafe. Follow your employer's guidelines on towing or pushing a disabled bus.

## Section 5: Air Brakes

This section is for drivers who drive or tow vehicles with air brakes

This section tells you about air brakes. If you drive or tow a commercial vehicle(s) equipped with air brakes, you will be tested on the information in this section. If you want to tow a trailer with air brakes, you must also read Section 6: Combination Vehicles.

Air brakes use compressed air to make the brakes work and must be well maintained and used correctly.

Air brake systems are three braking systems combined:

- The **service brake** system applies and releases the brakes when you use the brake pedal during normal driving.
- The **parking brake** system applies and releases the parking brakes when you use the parking brake control.
- The **emergency brake** system uses parts of the service and parking brake systems to stop the vehicle in the event of a brake system failure.

**CDL Air Brake Requirements.** For CDL purposes, a vehicle's air brake system must meet the above definition and must contain the following which will be checked during the pre-trip inspection test:

- Air gauges.
- Low pressure warning device(s).

If the vehicle you use for your driving test does not have these components, your vehicle will not be considered as having an air brake system and you will have a "No Air Brakes" restriction on your CDL.

**NOTE:** A full service brake application must deliver to all brake chambers not less than 90 percent of the air reservoir pressure remaining with the brakes applied. (VC §26502)

### The Air Brake System

An air brake system is a system that uses air as a way to transmit pressure from the driver's control to the service brake. It also includes an air-over-hydraulic brake system.

There are many parts to an air brake system. You should know about the parts discussed here.

### Air Compressor And Governor

The air compressor pumps air into the air storage tanks (reservoirs). The air compressor is connected to the engine through gears or a V-belt. The compressor may be air cooled or may be cooled by the engine cooling system. It may have its own oil supply, or be lubricated by engine oil. If the compressor has its own oil supply check the oil level before driving.

The governor controls when the air compressor will pump air into the air storage tanks. When air tank pressure rises to the "cut-out" level (no higher than 130 lbs. per square inch, or "p.s.i."), the governor stops the compressor from pumping air. When the tank pressure falls to the "cut-in" pressure (no lower than 85 p.s.i.), the governor allows the compressor to start pumping again.

### Air Storage And Drain Tanks

Air storage tanks are used to hold compressed air. The number and size of air tanks varies among vehicles. The tanks will hold enough air to allow the brakes to be used several times even if the compressor stops working.

Compressed air usually has some water and some compressor oil in it. This is bad for the air brake system. For example, the water can freeze in cold weather and cause brake failure. The water, oil, etc., tends to collect in the bottom of the air tank. Each air tank is equipped with a drain valve in the bottom. There are three types:

- Manually operated by turning a quarter turn, shown in Figure 5-1, or by pulling a cable. You must drain the tanks yourself at the end of each day of driving.
- Automatic. The water and oil are automatically expelled from the valve (these valves are equipped for manual draining as well).
- Spit valve. The water and oil are automatically expelled from a spit valve. The type of valve “spits” out water and air each time the governor cycles.

The automatic types are available with electric heating devices. These help prevent freeze up of the automatic drain in cold weather.

### Alcohol Evaporator

Some air brake systems have an alcohol evaporator to put alcohol into the air system. This helps to reduce the risk of ice in air brake storage tanks, valves, and other parts during cold weather. Ice inside the system can cause brake failure.

Check the alcohol container and fill up as necessary every day during cold weather. Daily air tank drainage is still needed to get rid of water and oil (unless the system has automatic drain valves).

### Safety Valve

A safety relief valve is installed in the first tank the air compressor pumps air into. The safety valve protects the tank and the rest of the system from too much air pressure. The valve is usually set to open at 150 p.s.i. If the safety valve releases air, something is wrong with the brake system.

### Brake Pedal

You apply the brakes by pushing down the brake pedal (also called the foot valve or treadle valve). The harder you push down on the pedal, the more air pressure is applied from the storage tanks into the brake chambers. Letting up on the brake pedal exhausts the air pressure from the brake chambers and releases the brakes. The air pressure used to apply the brakes must be built up in the reservoirs by the compressor. Pressing and releasing the pedal (fanning) can unnecessarily let air out faster than the compressor can replace it. If the pressure gets too low, the brakes will not work.

When you push the brake pedal down, two forces push back against your foot. One force comes from a spring in the valve. The second force comes from the air pressure going to the brake chambers. This lets you feel how much air pressure is being applied to the brake chambers. This “feel” does not tell you how much force is being applied to the brakes because that depends on brake adjustment.

### Drum Brakes

Drum brakes (foundation brakes) may be used at each wheel. The most common type is the S-cam drum brake (so called because of its shape) shown in Figure 5-2.

**Brake drums, shoes, and linings.** Brake drums are located on each end of the vehicle’s axles. The wheels are bolted to the drums. The braking mechanism is inside the drum. To stop, the brake shoes and linings are pushed against the inside of the drum. This causes friction which slows the vehicle (and creates heat). The heat a drum can take without damage depends on how hard

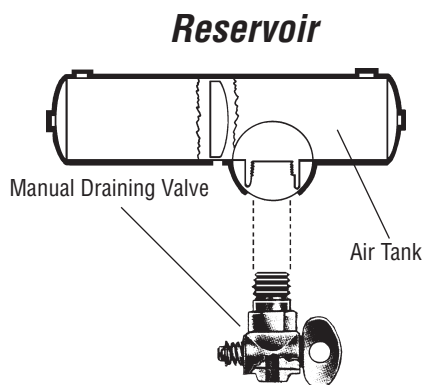

Figure 5-1 Manual Drain Valve

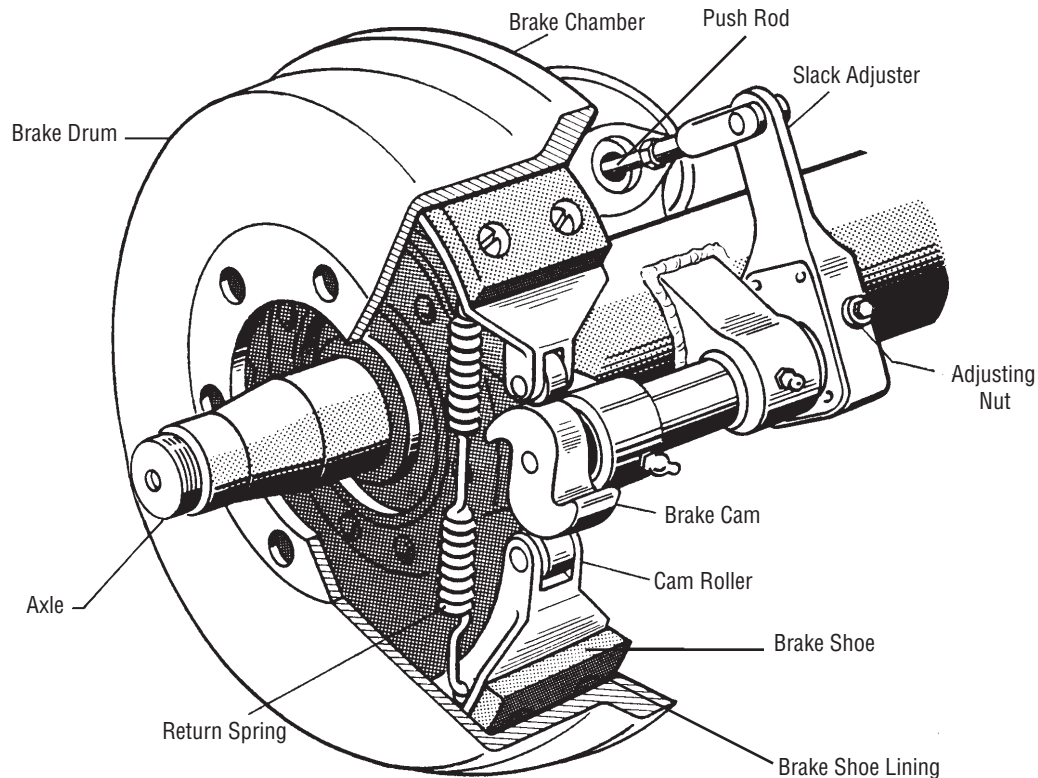

Figure 5-2 S-cam Air Brake

and how long the brakes are used. Too much heat can cause brake failure.

**S-cam brakes.** When you push the brake pedal, air is let into each brake chamber (Figure 5-2). Air pressure pushes the rod out, moving the slack adjuster, thus twisting the brake cam shaft. This turns the S-cam. The S-cam forces the brake shoes away from one another and presses them against the inside of the brake drum. When you release the brake pedal, the S-cam rotates back and a spring pulls the brake shoes away from the drum, letting the wheels roll freely again.

**CamLaster.** The CamLaster brake has two key design differences over traditional S-cam brakes. One feature is a completely internal adjustment system which is designed to continually keep the brake in proper adjustment. S-cam brakes, on the other hand, require an external slack

adjuster. The second feature is a unique cam design that applies the brake shoe. Unlike a standard drum brake that has either a single or double anchor-pin brake, CamLaster slides the shoes down an inclined ramp on a cam to evenly contact the brake drum.

**Wedge brakes.** The brake chamber push rod pushes a wedge directly between the ends of two brake shoes. This shoves them apart and against the inside of the brake drum. Wedge brakes may have a single brake chamber, or two brake chambers, pushing wedges in at both ends of the brake shoes. Wedge type brakes may be self-adjusting or may require manual adjustment.

**Disc brakes.** In air-operated disc brakes, air pressure acts on a brake chamber and slack adjuster, like S-cam brakes. But instead of the

S-cam, a “power screw” is used. The pressure of the brake chamber on the slack adjuster turns the power screw. The power screw clamps the disc or rotor between the brake lining pads of a caliper, similar to a large C-clamp.

### One-Way Check Valve

This device allows air to flow in one direction only. All air tanks on air-braked vehicles must have a check valve located between the air compressor and the first reservoir. (VC §26507) The check valve keeps air from going out if the air compressor develops a leak.

### Air Supply Pressure Gauge

All air-braked vehicles have an air supply pressure gauge connected to the air tank. If the vehicle has a dual air brake system, there will be a gauge for each half of the system or, sometimes, a single gauge with two needles. Dual systems will be discussed later. These gauges tell you how much pressure is in the air tanks.

### Application Pressure Gauge

This gauge shows how much air pressure you are applying to the brakes (some vehicles do not have this gauge). When going down steep grades, increasing brake pressure to hold the same speed means the brakes are fading. The need for increased pressure can also be caused by brakes out of adjustment, air leaks, or mechanical problems.

### Low Air Pressure Warning Gauge

A low air pressure warning device is required on vehicles with air brakes. A warning device which you can see must come on when the air supply pressure drops between 55 to 75 p.s.i. or one half the compressor governor cut-out pressure on older vehicles. The warning is usually a red light. A buzzer may also come on.

Another type of warning is the “wig wag.” This device drops a mechanical arm into your view when the pressure in the system drops

between 55 to 75 p.s.i. An automatic wig wag will rise out of your view when the pressure in the system goes above 55 or more p.s.i. The manual reset type must be placed in the “out of view” position manually. It will not stay in place until the pressure in the system is between 55 to 75 p.s.i.

On large buses, it is common for the low pressure warning devices to signal at 80 to 85 p.s.i.

Farm labor vehicles and Type I school buses must have both an audible and visual type warning device.

### Stop Light Switch

Drivers behind you must be warned when you apply your brakes. The air brake system does this with an electric switch that works by air pressure. The switch turns on the brake lights when you apply the air brakes.

### Front Brake Limiting Valve

Some vehicles made before 1975 have a front brake limiting valve and a control in the cab. The control is usually marked “normal” and “slippery.” When you put the control in the slippery position, the limiting valve cuts the normal air pressure to the front brakes by half. Limiting valves are used to reduce the chance of the front wheels skidding on slippery surfaces. However, they also reduce the stopping power of the vehicle. Front wheel braking is good under all conditions. Tests have shown front wheel skids from braking are not likely even on ice. *Make sure the control is in the normal position to have normal stopping power.*

Many vehicles have automatic front wheel limiting valves. They reduce the air to the front brakes except when the brakes are stepped on very hard (60 p.s.i. or more application pressure). These valves cannot be controlled by the driver. (NOTE: Some vehicles are manufactured with no front brakes.)



## Spring Brakes

All trucks, truck tractors, and buses using air pressure to apply the service brakes must be equipped with emergency brakes and parking brakes. The parking brake must be held on by mechanical force (because air pressure can eventually leak away). Spring brakes are usually used to meet the emergency and parking brake requirements. When driving, powerful springs are held back by air pressure. If the air pressure is removed, the springs put on the brakes. A parking brake control in the cab allows the driver to let the air out of the spring brakes. This lets the springs put on the brakes. A leak in the air brake system will generally cause the springs to put on the brakes.

Tractor and straight truck spring brakes will come fully on when air pressure drops to a range of 20 to 45 p.s.i. (typically 20 to 30 p.s.i.). Do not wait for the brakes to come on automatically. When the low air pressure warning light and buzzer first come on, bring the vehicle to a safe stop right away while you can still control the brakes.

The braking power of spring brakes depends on the brakes being in adjustment. If the brakes are not adjusted, neither the regular brakes nor the emergency/parking brakes will work correctly.

## Parking Brake Controls

In newer vehicles with air brakes, set the parking brakes using a diamond shaped, yellow, push-pull control knob. Pull the knob out to set the parking brakes (spring brakes), and push it in to release them. On older vehicles, the parking brakes may be controlled by a lever. Use the parking brakes whenever you park.

**Caution.** If your vehicle is not equipped with an anti-compound system (only in vehicles with air brakes), you should not push the brake pedal down when the spring brakes are on. If you do, the brakes could be damaged by the combined forces of the springs and the air pressure. Many brake systems are designed so this will not

happen. But not all systems are set up that way and those that are may not always work. It is much better to develop the habit of not pushing the brake pedal down when the spring brakes are on.

**Modulating control valves.** In some vehicles a control handle on the dash board may be used to apply the spring brakes gradually. This is called a modulating valve. It is spring loaded so you have a feel for the braking action. The more you move the control lever, the harder the spring brakes come on. They work this way so you can control the spring brakes if the service brakes fail. When parking a vehicle with a modulating control valve, move the lever as far as it will go and hold it in place with the locking device.

**Dual parking control valve.** When main air pressure is lost, the spring brakes come on. Some vehicles, such as buses, have a separate air tank which can be used to release the spring brakes. This is so you can move the vehicle in an emergency. One of the valves is a push-pull type and is used to put on the spring brakes for parking. The other valve is spring loaded in the "out" position. When you push the control in, air from the separate air tank releases the spring brakes so you can move. When you release the button, the spring brakes come on again. There is only enough air in the separate tank to do this a few times.

## Dual Air Brake Systems

Most newer heavy-duty vehicles use dual air brake systems for safety. A dual air brake system has two separate air brake systems which use a single set of brake controls. Each system has its own air tanks, hoses, lines, etc. One system typically operates the regular brakes on the rear axle or axles. The other system operates the regular brakes on the front axle and possibly one rear axle. Both systems supply air to the trailer, if there is one. The first system is called the *primary* system and the other is called the *secondary* system.

Before driving a vehicle with a dual air system, allow time for the air compressor to build up a minimum of 100 p.s.i. pressure in both the primary and secondary systems. Watch the primary and secondary air pressure gauges (or needles, if the system has two needles in one gauge). The low air pressure warning light and buzzer should shut off when air pressure in both systems rises to a value set by the manufacturer. This value must be greater than 55 p.s.i.

The warning system devices should come on before the air pressure drops below 55 p.s.i. in either system. If one air system is very low on pressure, either the front or the rear brakes will not be operating fully. This means it will take you longer to stop. Bring the vehicle to a safe stop and have the air brake system fixed.

## Combination Vehicle Air Brakes

The trailer hand valve (also called the trolley valve or Johnson bar) works the trailer brakes. The trailer hand valve should be used only to test the trailer brakes. Do not slow a tractor and semitrailer combination by using only the trailer hand brake. Do not use it in driving because of the danger of making the trailer skid. The foot brake sends air to all of the brakes on the vehicle including the trailers. There is much less danger of causing a skid or jackknife when using just the foot brake.

### Trailer Hand Valve

Never use the hand valve for parking, because all the air might leak out, unlocking the brakes (in trailers that do not have spring brakes). Always use the parking brakes when parking. If the trailer does not have spring brakes, use wheel chocks to keep the trailer from moving.

### Tractor Protection Valve

The tractor protection valve keeps air in the tractor or truck if the trailer breaks away or develops a bad leak. The tractor protection valve is controlled by the trailer air supply control

valve in the cab. The control valve allows you to open and shut the tractor protection valve. It will close automatically if air pressure is low (in the range of 20 to 45 p.s.i.). When the valve closes, it stops any air from escaping and lets the air out of the trailer emergency line which causes the trailer emergency brakes to come on. (Emergency brakes are covered later.)

The trailer air supply control on newer vehicles is a red 8-sided knob which controls the tractor protection valve. Push it in to supply the trailer with air, and pull it out to shut the air off and put on the trailer emergency brakes. The valve will pop out and close the tractor protection valve when the air pressure drops into the range 20 to 45 p.s.i. Emergency valves on older vehicles may not operate automatically. There may be a lever rather than a knob. The normal position is used for pulling a trailer. The emergency position is used to shut the air off and put on the trailer emergency brakes.

### Trailer Air Lines

Every combination vehicle has two air lines—the service line and the emergency line. They run between each vehicle (tractor to trailer, trailer to dolly, dolly to second trailer, etc.).

**Service air line (normally blue).** The *service* line (also called the control line or signal line) carries air which is controlled by the foot brake or the trailer hand brake. The pressure in the service line will similarly change depending on how hard you press the foot brake or hand valve. The service line is connected to a relay valve on the trailer to apply more or less pressure to the trailer brakes. The relay valve connects the trailer air tanks to the trailer air brakes. As pressure builds up in the service line, the relay valve opens and sends air pressure from the trailer air tank to the trailer brake chambers, putting on the trailer brakes.

**Emergency air line (normally red).** The emergency line has two purposes. First, it supplies air to the trailer air tanks and secondly, the emergency line controls the emergency brakes

on combination vehicles. Loss of air pressure in the emergency line causes the trailer emergency brakes to come on. The pressure loss could be caused by a trailer breaking loose, tearing apart the emergency air hose. It could also be caused by a hose, metal tubing, or other part which breaks, letting the air out. When the emergency line loses pressure, it causes the tractor protection valve to close (the air supply knob will pop out).

### Hose Couplers (Glad Hands)

Glad hands are coupling devices used to connect the service and emergency air lines from the truck or tractor to the trailer. The couplers have a rubber seal which prevents air from escaping. Clean the couplers and rubber seals before a connection is made. When connecting the glad hands, press the two seals together with the couplers at a 90° angle to each other. A turn of the glad hand attached to the hose will join and lock the couplers.

**It is very important to keep the air supply clean.** To keep the air supply clean, some vehicles have “dead end” or dummy couplers to which the hoses may be attached when they are not in use. This will prevent water and dirt from getting into the coupler and the air lines. Use the dummy couplers, if available, when the air lines are not connected to a trailer.

To avoid mistakes, metal tags are sometimes attached to the lines with the words *service* or *emergency* stamped on them. Sometimes colors are used. Blue is used for the service lines and red for the emergency lines.

If you do cross the air lines, supply air will be sent to the service line instead of going to charge the trailer air tanks. Air will not be available to release the trailer spring brakes (parking brakes). If the spring brakes don't release when you push the trailer air supply control, check the air line connections.

Older trailers do not have spring brakes. If the air supply in the trailer air tank has leaked away there will be no emergency brakes and the trailer

wheels will turn freely. If you crossed the air lines, you could drive away but you would not have trailer brakes. Before driving, always test the trailer brakes with the hand valve or by pulling the air supply control. Pull gently against them in a low gear to make sure the brakes work.

### Trailer Air Tanks

Each trailer and converter dolly has one or more air tanks. They are filled by the emergency supply line from the tractor and they provide the air pressure used to operate trailer brakes. Air pressure is sent from the air tanks to the brakes by relay valves. The pressure in the service line tells how much pressure the relay valves should send to the trailer brakes. The pressure in the service line is controlled by the brake pedal and the trailer hand brake.

It is important that you do not let water or oil build up in the air tanks. If you do, the brakes may not work. Each tank has a drain valve on it, and must be drained every day. If your tanks have automatic drains, they will keep most moisture out. However, you should still open the drains to check for moisture.

### Shut-Off Valves

Shut-off valves (also called cut-out cocks) are used in the service and supply air lines at the back of the trailers used to tow other trailers. These valves permit closing the air lines when no other trailer is being towed. You must check that all shut-off valves are in the open position except the ones at the back of the last trailer, which must be closed.

### Service, Spring, And Emergency Brakes

Newer trailers have spring brakes just like trucks and truck tractors. However, converter dollies and trailers built before 1975 are not required to have spring brakes. These have emergency brakes which work from the air stored in the trailer air tank. The emergency brakes come

on whenever air pressure in the emergency line is lost. These trailers have no parking brake. The emergency brakes come on whenever the air supply knob is pulled out or the trailer is disconnected. The brakes will hold only as long as there is air pressure in the trailer air tank. Eventually, the air will leak away and then there will be no brakes. It is very important that you use wheel chocks when you park trailers without spring brakes.

A major leak in the emergency line will cause the tractor protection valve to close and the trailer emergency brakes to come on.

You may not notice a major leak in the service line until you try to put the brakes on. Then, the air loss from the leak will lower the air tank pressure quickly. If it goes low enough, the trailer emergency brakes will come on.

## Inspecting The Air Brake System

Use the basic inspection procedures described in Sections 2 or 4 to inspect your vehicle. There are more items to inspect on a vehicle with air brakes than one without them.

### Engine Compartment

**Check air compressor drive belt.** If the air compressor is belt-driven, check for excessive wear, cracks, and tightness of the belt.

### Walkaround

**Check brake adjustment on S-cam brakes.** Park on level ground and chock the wheels to prevent the vehicle from moving. Release the parking brakes on the truck or tractor and the emergency brakes on the trailer so you can mark the push rod in the unapplied position. Make a mark on the push rod with a chalk or scribe close to the brake chamber where the push rod comes out of the air chamber. Apply the truck or tractor parking brake and the trailer emergency braking system. Measure the travel of the push rod from the brake chamber and the mark you made with

the chalk or scribe at each brake chamber. The push rod should move less than two inches on most brakes. (Smaller brake cams will have less push rod travel.)

If the brake push rod exceeds the required adjustment, adjust it or have it adjusted. (You are not expected to adjust them during the pre-trip test but you are expected to describe how to check that the brake push rod is adjusted properly.) Vehicles with too much brake slack can be very hard to stop. Out-of-adjustment brakes are the problem most often found in roadside inspections. Be safe—check the slack adjusters.

**Check brake drums (or discs), linings, and hoses.** Brake drums must not have cracks. Linings must not be loose or soaked with oil or grease. They should not be thinner than the manufacturers specifications recommend. (Generally, this will be 1/4 inch.) Mechanical parts must be in place, not broken or missing. Check the air hoses connected to the brake chambers to make sure they are not cracked, cut, or worn.

### In-Cab Air Brake Check

**NOTE:** All the Air Brakes system tests in this section are considered important and each can be considered critical parts of the in-cab air brakes tests. The items marked with an asterisk (\*) in this section are required for testing purposes during the pre-trip portion of the CDL driving test. They may be performed in any order as long as they are performed correctly and effectively. If these items are not demonstrated and the parameters for each test is not verbalized correctly, it is considered an automatic failure of the pre-trip portion of the test.

**Testing air leakage rate.** There are two tests as follow:

#### Static Leakage Test

With a basically fully-charged air system (within the effective operating range for the compressor), turn off the engine, release all brakes, and let the

system settle (air gauge needle stops moving). Time for one minute. The air pressure should not drop more than:

- 2 p.s.i. for single vehicles.
- 3 p.s.i. for a combination of two vehicles.
- 5 p.s.i. for a combination of three or more vehicles.

An air loss greater than those shown indicate a problem in the braking system and repairs are needed before operating the vehicle.

### **\*Applied Leakage Test**

With a basically fully-charged air system (within the effective operating range for the compressor), turn off the engine, release all brakes so the entire system is charged. Allow the system to settle (air gauge needle stops moving), apply firm, steady pressure to the brake pedal (brake on), and hold. After the system settles again, time for one minute. The air pressure should not drop more than:

- 3 p.s.i. for single vehicles.
- 4 p.s.i. for a combination of two vehicles.
- 6 p.s.i. for a combination of three or more vehicles.

An air loss greater than those shown indicate a problem in the braking system and repairs are needed before operating the vehicle.

**NOTE:** You must be able to demonstrate this test and verbalize the allowable air loss for the examiner on this test.

If the air loss is too much, check for air leaks and fix. For testing purposes, identify if the air loss rate is too much.

### **\*Air Compressor Governor Cut-Out Pressure Test**

To perform this test, the air pressure for the vehicle must be rising when the engine is running. Run the engine at a fast idle. The air compressor governor must cut-out prior to the needle reaching 130 psi. Where the needle stops rising is the governor cut-out pressure.

For testing purposes, identify where the air governor cuts out the compressor and verbalize the maximum pressure at which this can occur.

**NOTE:** The air dryer exhausting should not be referenced as governor cut-out.

### **\*Air Compressor Governor Cut-In Pressure Test**

To perform this test, the air pressure for the vehicle cannot be rising when the engine is running. With the engine idling, slowly pump the brake pedal to reduce the air tank pressure. Watch the air pressure gauge between pumps to identify when the compressor cuts in (needle starts to rise). This should occur no lower than 85 psi.

For testing purposes, identify where the air governor cuts in the compressor and verbalize the minimum pressure at which this can occur.

### **\*Low Air Pressure Warning Device Test**

This test may be performed with engine on or off. To perform the test with the engine off, turn the electrical power on and have enough air pressure to keep the low air pressure warning device from coming on. Slowly pump the brake pedal to reduce air tank pressure. The low air pressure warning device must activate between 55 and 75 p.s.i. For testing purposes, identify when the warning signal activates, and verbalize the legal range in which the signal must activate.

If the warning signal does not work, you could lose air pressure and not know it. This could cause sudden emergency braking in a single circuit air system. In dual systems the stopping distance will be increased. Only limited braking can be done before the spring brakes come on.

**Check that the trailer brakes come on automatically.** Chock the wheels. Release the truck or tractor parking brakes and shut the engine off. Pump the brake pedal to reduce the air tank pressure. The trailer air supply valve knob should pop out when the air pressure falls

to the manufacturer's specifications (usually in a range between 20 to 40 p.s.i.). This causes the trailer emergency brakes to come on. Some trailers use an air applied emergency brake system and some trailers use spring brakes as the emergency brake system.

**Check rate of air pressure buildup.** With the engine at operating rpms, the pressure should build from 85 to 100 p.s.i. within 45 seconds in dual air systems. If the vehicle has larger than minimum air tanks, the buildup time can be longer and still be safe. Check the manufacturer's specifications. In single air systems (pre-1975), typical requirements are pressure buildup from 50 to 90 p.s.i. within 3 minutes with the engine at an idle speed of 600-900 rpms.

If air pressure does not build up fast enough, the pressure may drop too low during driving, requiring an emergency stop.

**Test service brakes.** Wait for normal air pressure, release the parking brake, move the vehicle forward slowly (about 5 mph), and apply the brakes firmly using the brake pedal. Any pulling to one side, unusual feel, or delayed stopping action should be checked.

**Test parking brake.** Fasten your seat belt. Set the parking brake and try to move the vehicle or allow the vehicle to slowly move forward and apply the brake. The parking brake should not allow any movement.

## Combination Vehicle Brake Check

In addition to those already listed in Section 2, complete these checks.

**Check that air flows to all trailers (double or triple trailers):**

- Use the tractor parking brake and/or chock the wheels to hold the vehicle.
- Wait for air pressure to reach normal.
- Use the trailer hand brake to provide air to the service line.
- Open the emergency line shut-off valve at

the rear of the last trailer (you should hear air escaping).

- Close the emergency line valve.
- Open the service line valve to check that service pressure goes through all the trailers, then close the valve.

If you do not hear air escaping from both lines, check that the shut-off valves on the other trailer(s) and dolly(ies) are in the OPEN position. You must have air all the way to the back for all the brakes to work.

**Test tractor protection valve:**

- Charge the trailer air brake system. (That is, build up normal air pressure and push in the air supply knob.)
- Shut off the engine.
- Pump the brake pedal several times to reduce the air pressure in the tanks. The trailer air supply control should pop out or go from the normal to the emergency position when the air pressure falls into the pressure range specified by the manufacturer (usually within the range of 20 to 45 p.s.i.).

If the tractor protection valve does not work correctly, an air hose or trailer brake leak could drain all the air from the tractor. This would cause the emergency brakes to come on, with possible loss of control.

**Test trailer emergency brakes:**

- Charge the trailer air brake system and check that the trailer rolls freely.
- Stop and pull out the trailer air supply control valve or place it in the emergency position.
- Pull gently on the trailer with the tractor to check that the trailer emergency brakes are on.

**Test trailer service brakes:**

- Check for normal air pressure.
- Release parking brakes.
- Move the vehicle forward, slowly.
- Apply the trailer brakes with the hand control (trolley valve), if so equipped.

You should feel the brakes come on. This tells you the trailer brakes are connected and working. The trailer brakes should be tested with the hand valve but controlled in normal operation with the foot pedal, which applies air to the service brakes at all wheels.

## Using Air Brakes

Push the brake pedal down until the vehicle comes to a smooth stop. If you have a manual transmission, don't push the clutch in until the engine rpm is close to idle. When you are stopped, select a starting gear. You should brake so you can steer and keep your vehicle in a straight line and allow you to turn if it becomes necessary. Use one of the following methods.

### Emergency Stops

**Controlled braking.** This method is also called "squeeze" braking. Put on the brakes as hard as you can without locking the wheels. Do not turn the steering wheel while doing this. If you need to make large steering adjustments or if you feel the wheels sliding, release the brakes. Brake again as soon as the tires get traction.

**Stab braking.** (Only on vehicles without antilock brake systems.)

- Press on the brake pedal as hard as you can.
- Release the brakes when the wheels lock up.
- As soon as the wheels start rolling, put on the brakes fully again.

It can take up to one second for the wheels to start rolling after you release the brakes. Make sure you stay off the brakes long enough to get the wheels rolling again. Otherwise the vehicle may not stay in a straight line.

**NOTE:** If you drive a vehicle with antilock brakes, you should read and follow the directions found in the owner's manual for stopping quickly.

## Stopping Distance

This was discussed in Section 2 under *Speed and Stopping Distances*. With air brakes there is an added delay: the time required for the brakes to work after the brake pedal is pushed. With hydraulic brakes (used on cars and light/medium trucks), the brakes work instantly. However, with air brakes, it takes time (up to one half second) for the air to flow through the lines to the brakes. Thus, the total stopping distance for vehicles with air brake systems is made up of four different factors.

$$\begin{array}{r}
 \text{Perception distance} \\
 + \text{ Reaction distance} \\
 + \text{ Brake lag distance} \\
 + \text{ Effective braking distance} \\
 = \text{ TOTAL STOPPING DISTANCE}
 \end{array}$$

The air brake lag distance at 55 mph on dry pavement adds about 32 feet. So at 55 mph for an average driver under good traction and brake conditions, the total stopping distance is over 300 feet. This is longer than a football field.

Brakes get hot from use and will stop working if there is too much heat. Excessive heat is caused by trying to slow down too many times or too quickly from a high speed. Brakes will fade when they get too hot and will not slow you.

### Brake Fade

Brakes are designed so brake shoes or pads rub against the brake drum or discs to slow the vehicle. Braking creates heat, but brakes are designed to take a lot of heat. However, brakes can fade or fail from excessive heat caused by using them too much and not relying on the braking effect of the engine.

Excessive use of the service brakes results in overheating and leads to brake fade. Brake fade results from excessive heat which causes chemical changes in the brake lining and expansion of the brake drums. As the overheated drums expand, the brake shoes and linings have to move farther to contact the drums, and the

force of this contact is also reduced. Continued overuse may increase brake fade until the vehicle cannot be slowed or stopped at all.

Brake fade is also affected by adjustment. To safely control a vehicle, every brake must do its share of the work. Brakes out of adjustment will stop doing their share before those that are in adjustment. The other brakes can then overheat and fade and there will not be sufficient braking available to control the vehicle(s). Brakes can get out of adjustment quickly, especially when they are hot. Therefore, brake adjustment must be checked frequently.

### Proper Braking Technique

**Remember:** The use of brakes on a long and/or steep downgrade is only a supplement to the braking effect of the engine. Once the vehicle is in the proper low gear, the following is the proper braking technique:

- Apply the brakes just hard enough to feel a definite slowdown.
- When your speed has been reduced to approximately 5 mph below your “safe” speed, release the brakes. (This brake application should last for about three seconds.)
- When your speed has increased to your “safe” speed, repeat the steps above.

For example, if your “safe” speed is 40 mph, you would not apply the brakes until your speed reaches 40 mph. You now apply the brakes hard enough to gradually reduce your speed to 35 mph and then release the brakes. Repeat this as often as necessary until you have reached the end of the downgrade.

### Low Air Pressure Warning Signal

If a low air pressure warning signal comes on, stop and safely park your vehicle as soon as possible. There may be an air leak in the system(s). Controlled braking is possible only while enough air remains in the air tanks. The spring brakes will come on when the air pressure drops into the range 20 to 45 p.s.i. A heavily loaded vehicle will take a long distance to stop, because the spring brakes do not work on all axles. Lightly loaded vehicles or vehicles on slippery roads may skid out of control when the spring brakes come on. Controlled braking is possible only while enough air remains in the air tanks.

### Parking Brakes

Any time you park, use the parking brakes, *except:*

- If the brakes are very hot, they can be damaged by the heat.
- In freezing temperatures, if the brakes are very wet, they will freeze and the vehicle will be immobilized.

### Air Tank Drains

Pull the parking brake control knob out to apply the parking brakes, push it in to release them. The control will be a yellow, diamond-shaped knob labeled “parking brakes” on newer vehicles. On older vehicles, it may be a round blue knob or some other shape (including a lever that swings from side to side or up and down).

Use wheel chocks to hold the vehicle. Let hot brakes cool before using the parking brakes. If the brakes are wet, use the brakes lightly while driving in a low gear to heat and dry them.

If your vehicle does not have automatic air tank drains, drain your air tanks at the end of each working day to remove moisture and oil. Otherwise, the brakes could fail.



## Section 6: Combination Vehicles

This section is for drivers who need a Class A CDL

This section provides information needed to pass the test for Class A combination vehicles (tractor-trailers, or straight truck and trailer). The information gives you the minimum knowledge needed for driving most combination vehicles.

You should also study Section 7 if you need to pass the tests for doubles/triples.

*Doubles/Triples Endorsement Needed*

### Driving Combination Vehicles Safely

Combination vehicles are heavier, longer, and require more driving skill than single commercial vehicles. This means that drivers of combination vehicles need more knowledge and skill than drivers of single vehicles. In this section, we list some important safety factors that apply specifically to combination vehicles.

#### Rollover Risks

More than half of truck driver deaths in crashes are from truck rollovers. As more cargo is stacked in a truck, the center of gravity gets higher from the road. The truck becomes easier to turn over. Fully loaded rigs are 10 times more likely to roll over in a crash than empty rigs.

The following two things will help to prevent rollovers: keep the cargo as close to the ground as possible, and go slowly around turns. Section 3 of this handbook talks about transporting cargo safely. Keeping cargo low is even more important in combination vehicles than in straight trucks. A trailer rollover is more likely if the load is to one side. Make sure your cargo is centered and spread out as much as possible.

Rollovers happen when you turn too fast. Go slowly around corners, onramps, and offramps. Avoid quick lane changes, especially when fully loaded.

#### Steer Gently

Trucks with trailers have a dangerous “crack-the-whip” effect. When you make a quick lane change, the crack-the-whip effect can turn the trailer over. There are many crashes where only the trailer has overturned.

Steer carefully when you are pulling trailers. If you make a sudden movement with your steering wheel you could tip over a trailer. Follow far enough behind other vehicles (at least one second for each ten feet of vehicle length, plus another second if going over 40 mph). Look far enough down the road to avoid being surprised and having to make a sudden lane change. At night, drive slowly enough to see obstacles before it is too late to change lanes or stop gently. Slow down to a safe speed before going into a turn.

#### Brake Early

Control your speed whether fully loaded or empty. Large combination vehicles that are empty take longer to stop than when they are fully loaded. When lightly loaded, the very stiff suspension springs and strong brakes give poor traction and make it very easy to lock up the wheels. When the wheels lock, your trailer can swing out and strike other vehicles or it can jackknife very quickly (Figure 6-1). You also must be very careful about driving “bobtail” tractors (tractors without semitrailers). Tests have shown that bobtails can be very hard to stop smoothly. It takes them longer to stop than a tractor and semitrailer loaded to maximum gross weight.

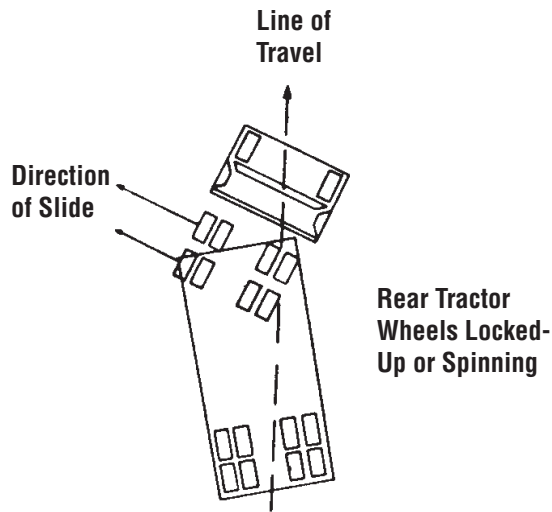

Figure 6-1 Tractor Jackknife

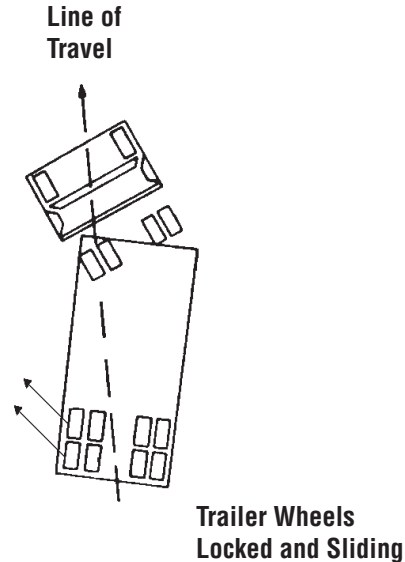

Figure 6-2 Trailer Jackknife

In any combination rig, allow adequate following distance and look far enough ahead so you can brake early. Do not be caught by surprise and have to make a panic stop.

### Avoid Trailer Skids

When the wheels of a trailer lock up, the trailer will tend to swing around. This is more likely to happen when the trailer is empty or lightly loaded. This type of jackknife is often called a “trailer jackknife.” This is shown in Figure 6-2. The procedure for stopping a trailer skid is as follows:

- **Recognize the skid.** The earliest and best way to recognize that the trailer has started to skid is by seeing it in your mirrors. Any time you apply the brakes hard, check the mirrors to make sure the trailer is staying where it should be. Once the trailer swings out of your lane, it is very difficult to prevent a jackknife.
- **Stop using the brake.** Release the brakes to get traction back. Do not use the trailer hand brake to straighten out the rig. This is the wrong thing to do since it is the brakes on the trailer wheels that caused the skid in the first place. Once the trailer wheels

grip the road again, the trailer will start to follow the tractor and straighten out.

### Make Wide Enough Turns

When a vehicle goes around a corner, the rear wheels follow a different path than the front wheels. This is called offtracking. Figure 6-3 shows how offtracking causes the path followed by a tractor and semitrailer to be wider than the rig itself. Longer vehicles will offtrack more. The rear wheels of the powered unit (truck or tractor) will offtrack some, and the rear wheels

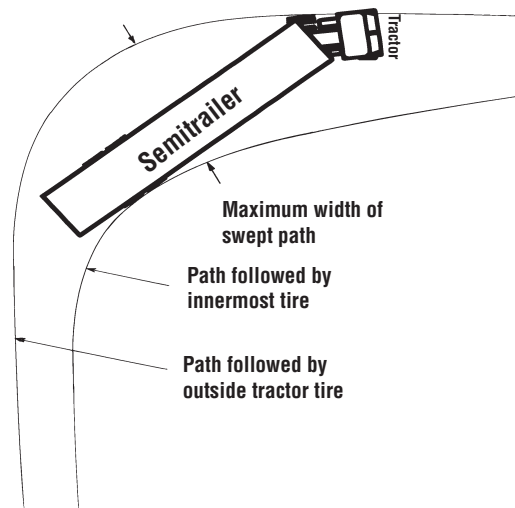

Figure 6-3 Offtracking in a 90 degree turn

of the trailer will offtrack even more. If there is more than one trailer, the rear wheels of the last trailer will offtrack the most. Steer the front end wide enough around a corner so the rear end does not run over the curb, pedestrians, other vehicles, etc. However, keep the rear of your vehicle close to the curb. This will stop other drivers from passing you on the right. If you cannot complete your turn without entering another lane of traffic, turn wide as you complete the turn. This is better than swinging wide to the left before starting the turn because it will keep other drivers from passing you on the right.

## Coupling And Uncoupling

Knowing how to couple and uncouple correctly is basic to safe operation of combination vehicles. Coupling and uncoupling incorrectly can be very dangerous. There are differences between different rigs, so learn the details of coupling and uncoupling the vehicle(s) you will operate. General coupling and uncoupling steps are listed below:

### Coupling Tractor/Semitrailers

#### Step 1. Inspect the fifth-wheel

- For damaged or missing parts.
- To see that mounting to tractor is secure, no cracks in frame, etc.
- To see that the fifth-wheel plate is completely greased. Failure to keep the fifth-wheel plate lubricated could cause steering problems because of friction between the tractor and trailer.
- To see that the fifth-wheel is in proper position for coupling.
  - the fifth-wheel should be tilted down towards the rear of the tractor with the jaws open and the safety unlocking handle in the automatic lock position.
- To see that the sliding fifth-wheel is locked.
- To see that the trailer kingpin is not bent or broken.

#### Step 2. Inspect area and chock wheels

- To be sure the area around the vehicle is clear.
- To be sure the trailer wheels are chocked or the spring brakes are on.
- To see that cargo (if any) is secured against movement during coupling.

#### Step 3. Position tractor

- Directly in front of the trailer. (Never back under the trailer at an angle because you might push the trailer sideways and break the landing gear.)
- Check position, using outside mirrors, by looking down both sides of the trailer.

#### Step 4. Back slowly

- Until the fifth-wheel just touches the trailer.
- Do not hit the trailer.

#### Step 5. Secure the tractor

- Set the parking brake.
- Put the transmission in neutral.

#### Step 6. Check the trailer height

- The trailer should be low enough that it is raised slightly by the tractor when the tractor is backed under it. Raise or lower the trailer as needed.
- To see that the kingpin and fifth-wheel are aligned.

#### Step 7. Connect the air lines to the trailer

- Check glad hand seals and connect tractor emergency air line to trailer emergency glad hand.
- Check glad hand seals and connect tractor service air line to trailer service glad hand.
- Make sure air lines are safely supported where they won't be crushed or caught while tractor is backing under the trailer.

#### Step 8. Supply air to the trailer

- From the cab, push in the air supply knob or move tractor protection valve control from

the “emergency” to the “normal” position to supply air to the trailer brake system.

- Wait until the air pressure is normal.
- Check brake system for crossed air lines:
  - shut engine off so you can hear the brakes.
  - apply and release trailer brakes and listen for sound of trailer brakes being applied and released. You should hear the brakes move when applied and air escape when the brakes are released.
  - check air brake system pressure gauge for signs of major air loss.
- When trailer brakes are working, start the engine.
- Air pressure must be up to normal.

### Step 9. Lock the trailer brakes

- Pull out the air supply knob or move the tractor protection valve control from normal to emergency.

### Step 10. Back under the trailer

- Use lowest reverse gear.
- Back tractor slowly under trailer to avoid hitting the kingpin.
- Stop when the kingpin is locked into the fifth-wheel.

### Step 11. Check the connection for security

- Raise the landing gear slightly off the ground.
- Pull forward gently against the trailer brakes to be sure that the trailer is locked to the tractor.

### Step 12. Secure the vehicle

- Put transmission in neutral.
- Put parking brakes on.
- Shut off the engine and take the key so someone will not move the truck.

### Step 13. Inspect the coupling

- Use a flashlight, if necessary.
- Make sure there is no space between the upper and lower fifth-wheel.
- Make sure the fifth-wheel jaws have closed around the shank of the kingpin. (Figure 6-4)
- Check that the locking lever is in the “lock” position.
- Check that the safety catch is in position over the locking lever.

### Step 14. Connect the electrical cord and check air lines

- Plug the electrical cord into the trailer and fasten the safety catch.
- Check both air and electrical lines for signs of damage.
- Make sure air and electrical lines will not hit any moving parts.

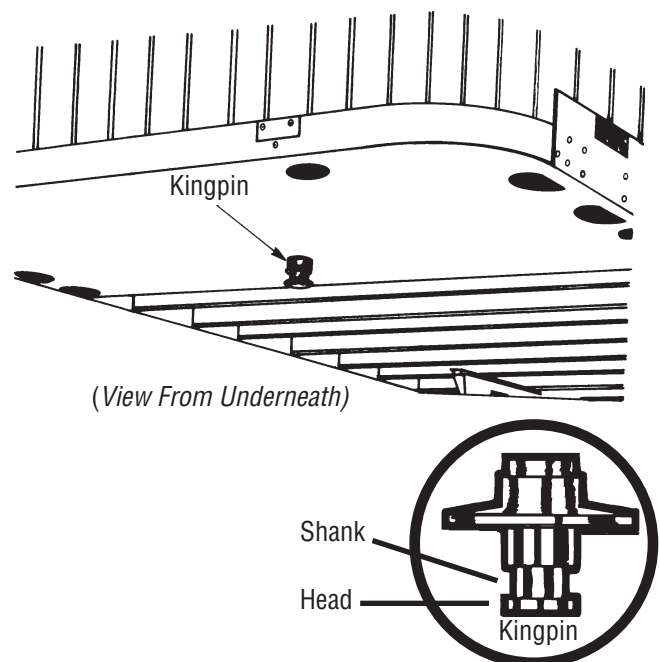

Figure 6-4 Trailer Kingpin

### **Step 15. Fully raise the front trailer supports (landing gear)**

- Use low gear range, if equipped, to begin raising the landing gear. Once free of weight, switch to the high gear range.
- Raise the landing gear all the way up.
- After raising landing gear, secure the crank handle safely.
- When full weight of trailer is resting on tractor:
  - check for clearance between the rear of the tractor frame and the landing gear.
  - check for clearance between the top of the tractor tires and the nose of the trailer.

### **Step 16. Remove and store the trailer wheel chocks**

#### **Uncoupling Tractor/Semitrailer**

The following steps will help you to uncouple safely:

#### **Step 1. Position the rig**

- Make sure surface of parking area can support weight of trailer.
- Have tractor lined up with the trailer.

#### **Step 2. Ease the pressure on the locking jaws**

- Shut off trailer air supply to lock trailer brakes.
- Ease pressure on fifth-wheel locking jaws by backing up gently.
- Put parking brakes on while tractor is pushing against the kingpin.

#### **Step 3. Chock the trailer wheels**

- Chock the trailer wheels if the trailer doesn't have spring brakes or if you are not sure.

#### **Step 4. Lower the landing gear**

- If trailer is empty—lower the landing gear until it makes firm contact with the ground.

- If trailer is loaded, after the landing gear makes firm contact with the ground, turn crank in low gear a few extra turns. This will lift some weight off the tractor. This will:
  - make it easier to unlatch fifth-wheel.
  - make it easier to couple next time.

#### **Step 5. Disconnect the air lines and electrical cable**

- Disconnect air lines from trailer. Connect air line glad hands to dummy couplers at back of cab or couple them together.
- Hang electrical cable with plug down to prevent moisture from getting in.
- Make sure lines are supported so they won't be damaged while driving the tractor.

#### **Step 6. Unlock the fifth-wheel**

- Raise the release handle lock.
- Pull the release handle to "open" position.
- Keep legs and feet clear of the rear tractor wheels to avoid serious injury.

#### **Step 7. Pull the tractor partially clear of the trailer**

- Pull tractor forward until fifth-wheel comes out from under the trailer.
- Stop with tractor frame under trailer

#### **Step 8. Secure the tractor**

- Apply parking brake.
- Place transmission in neutral.

#### **Step 9. Inspect the trailer supports**

- Make sure ground is supporting trailer.
- Make sure landing gear is not damaged.

#### **Step 10. Pull the tractor clear of the trailer**

- Release parking brakes.
- Check the area and drive tractor forward until it clears.

## Inspecting A Combination Vehicle

Use the inspection procedures described in Sections 2 and 10 to inspect your combination vehicle. However, there are more items to inspect on a combination vehicle than on a single vehicle.

In addition to the checks already listed in Section 2, complete these checks:

### Additional Items For Walkaround Inspection

#### Coupling system areas:

- Fifth-wheel (lower):
  - securely mounted to frame
  - no missing, damaged parts
  - properly greased
  - no visible space between upper and lower fifth-wheel
  - locking jaws around the shank, not the head of the kingpin
  - release arm properly seated and safety latch/lock engaged

- Fifth-wheel (upper):
  - glide plate securely mounted to trailer frame
  - kingpin not damaged
- Air and electric lines to trailer:
  - electrical cord firmly plugged in and secured
  - air lines properly connected to glad hands, no air leaks, properly secured with enough slack for turns
  - all lines free from damage
- Sliding fifth-wheel:
  - slide not damaged or parts missing
  - properly greased
  - all locking pins present and locked in place
  - if air powered—no air leaks
  - fifth-wheel not so far forward that tractor frame will hit landing gear, or cab hit the trailer, during turns

#### Landing gear:

- Fully raised, no missing parts, not bent or otherwise damaged.
- Crank handle in place and secured.
- If power operated, no air or hydraulic leaks.

## Section 7: Doubles and Triples

This section is for drivers who tow doubles or triples

This section has information you will need to pass the CDL knowledge test for driving safely with double/triple trailers. You should also study Sections 2, 5, and 6.

**NOTE:** Triple combinations are not legal in California. Triples are discussed in this section because they are legal in many other states.

The endorsement for *doubles* is given by written test only. **Do not bring in a set of doubles** for the driving test. Drivers must demonstrate the ability to back up the combination during the skills test, and backing doubles is dangerous.

*A Doubles/Triples Endorsement is Needed.*

### Towing Double/Triple Trailers

Take special care when towing two or three trailers. There are more things that can go wrong and doubles/triples are less stable than other commercial vehicles.

#### Prevent Trailer Rollover

To prevent trailers from rolling over, you must steer gently and go slowly around corners, onramps, offramps, and curves. A safe speed on a curve for a straight truck or a single trailer combination vehicle may be too fast for a set of doubles or triples.

Doubles and triples are more likely to turn over than other combination vehicles because of the crack-the-whip effect. You must steer gently when pulling trailers. The last trailer in a combination is most likely to turn over.

#### Inspect Completely

There are more critical parts to check when you have two or three trailers. Check them all. Follow the procedures described later in this section.

Doubles and triples must be driven very smoothly to avoid rollover or jackknife. Therefore, look far ahead so you can slow or change lanes gradually when necessary.

#### Manage Space

Doubles and triples take up more space than other commercial vehicles. They are not only longer, but also need more space on the road because they can't be turned or stopped suddenly. Allow more following distance. Make sure you have large enough gaps before entering or crossing traffic. Be certain you are clear at the sides before changing lanes. Look far ahead so you can slow down or change lanes gradually when necessary.

#### Adverse Conditions

Be more careful in bad weather conditions. In bad weather, slippery conditions, and mountain driving you must be especially careful if you drive double or triple bottoms. You will have greater length and more dead axles to pull with your drive axles than other drivers. There is more chance for skids and loss of traction.

### Coupling And Uncoupling

Knowing how to couple and uncouple correctly is basic to safe operation of doubles and triples. Incorrect coupling and uncoupling can be very dangerous. Couple the tractor and first semitrailer as described in Section 6.

## Coupling Twin Trailers

**Secure the second or rear trailer.** If the second trailer does not have spring brakes, drive the tractor close to the trailer, connect the emergency line, charge the trailer air tank, and disconnect the emergency line. This will set the trailer emergency brakes if the slack adjusters are correctly adjusted. Chock the wheels.

**NOTE:** For safe handling on the road, the more heavily loaded semitrailer must always be in the first position behind the tractor. The lighter trailer should be in the rear.

A converter gear or dolly is a coupling device of one or two axles and a fifth-wheel by which a semitrailer can be coupled to the rear of a tractor-trailer combination forming a double bottom rig.

### Position the converter dolly in front of the second or rear trailer:

- Release the dolly brakes by opening the air tank petcock. (Or, if the dolly has spring brakes, use the dolly parking brake control.)
- If possible, wheel the dolly into position by hand so it is in line with the kingpin.
- Or, use the tractor and first semitrailer to pick up the converter dolly:
  - position combination as close as possible to converter dolly
  - move dolly to rear of first semitrailer and couple it to the trailer
  - lock pintle hook
  - secure dolly support in raised position
  - pull dolly into position as close as possible to nose of the second semitrailer
  - lower dolly support
  - unhook dolly from first trailer
  - wheel dolly into position in front of second trailer in line with the kingpin

### Connect the converter dolly to the front trailer:

- Back first semitrailer into position in front of the dolly tongue.

- Hook dolly to front trailer:
  - lock pintle hook
  - secure converter gear support in raised position

### Connect the converter dolly to the rear trailer:

- Lock trailer brakes and/or chock wheels.
- Make sure trailer height is correct. (It must be slightly lower than the center of the fifth-wheel so the trailer is raised slightly when the dolly is pushed under.)
- Back converter dolly under rear trailer.
- Raise landing gear slightly off ground.
- Test coupling by pulling against pin of rear trailer.
- Check coupling and locking jaws.
- Connect safety chains, air hoses, and electrical cords.
- Close converter dolly air tank petcock, and shut-off valves at rear of second trailer.
- Open shut-off valves at rear of first trailer and on the dolly, if so equipped.
- Raise the landing gear completely.
- Charge trailers and check for air at the rear of the second trailer by opening the emergency line shut-off.

## Uncoupling Double Trailers

### Uncouple rear trailer:

- Park rig in a straight line.
- Apply parking brakes.
- Chock wheels of the second trailer.
- Lower the landing gear of the second semitrailer enough to remove some weight from the dolly.
- Close air shut-offs at rear of the first semitrailer and on the dolly, if so equipped.
- Disconnect all dolly air and electric lines and secure them.
- Release dolly brakes.
- Release converter dolly fifth-wheel latch.
- Slowly pull tractor, first semitrailer and dolly forward to pull dolly out from under rear semitrailer.



### Uncouple converter dolly:

- Lower dolly landing gear.
- Disconnect safety chains.
- Apply converter gear spring brakes or chock wheels.
- Release pintle hook on first semitrailer.
- Slowly pull clear of dolly.

**CAUTION:** Never unlock the pintle hook with the dolly still under the rear trailer. The dolly tow bar may fly up, possibly causing injury, and making it very difficult to re-couple.

### Coupling And Uncoupling Triple Trailers

#### Couple second and third trailers:

- Couple second and third trailers using the method for coupling doubles.
- Uncouple tractor and pull away from the second and third trailers.

#### Couple tractor/first semitrailer to second/third trailers:

- Couple tractor to first trailer. Use the method already described for coupling tractor-semitrailers.
- Move converter dolly into position and couple first trailer to second trailer using the method for coupling doubles. Triples rig is now complete.

#### Uncouple triple trailer rig:

- Uncouple third trailer by pulling the dolly out, then unhitching the dolly, using the method for uncoupling doubles.
- Uncouple remainder of rig as you would any double-bottom rig using the method already described.

**REMEMBER:** Operating triples is not allowed in California.

### Coupling and Uncoupling Other Combinations

The methods described so far apply to the more common tractor-trailer combinations. However, there are other ways of coupling and uncoupling the many types of truck-trailer and tractor-trailer combinations that are in use. There are too many to cover in this handbook. Learn the right way to couple the vehicle(s) you will drive according to the manufacturer and/or vehicle owner.

### Inspecting Doubles And Triples

There are more items to inspect on a combination vehicle than on a single vehicle. Many of these items are simply more of what you would find on a single vehicle. However, there are also some new items to check. These are discussed below.

### Additional Items For Walkaround Inspection

#### Coupling system areas:

- Fifth-wheel (lower):
  - securely mounted to frame
  - no missing, damaged parts
  - properly greased
  - no visible space between upper and lower fifth-wheel
  - locking jaws around the shank, not the head of the kingpin
  - release arm properly seated and safety latch/lock engaged
- Fifth-wheel (upper):
  - glide plate securely mounted to trailer frame
  - kingpin not damaged
- Air and electric lines to trailer:
  - electrical cord firmly plugged in and secured
  - air lines properly connected to glad hands, no air leaks, properly secured with enough slack for turns
  - all lines free from damage

- Sliding fifth-wheel:
  - slide not damaged or parts missing
  - properly greased
  - all locking pins present and locked in place
  - if air powered—no air leaks
  - fifth-wheel not so far forward that tractor frame will hit landing gear, or cab hit the trailer, during turns

**Landing gear:**

- Fully raised, no missing parts, not bent or otherwise damaged.
- Crank handle in place and secured.
- If power operated, no air or hydraulic leaks.

**Double and triple trailers:**

- Shut-off valves (at rear of trailers, in service and emergency lines):
  - rear of front trailer(s): OPEN
  - rear of last trailer: CLOSED. (Glad hands should be covered to protect from debris.)
  - converter dolly air tank drain valve: CLOSED
- Be sure air lines are supported and glad hands are properly connected.

- If spare tire is carried on converter gear (dolly), make sure it is secured.
- Be sure pintle-eye of dolly is in place in pintle hook of trailer(s).
- Make sure pintle hook is latched.
- Safety chains should be secured to trailer(s).
- Be sure electrical cords are firmly in sockets on trailers.

## Doubles/Triples Air Brake Check

Check the brakes on a double or triple trailer as you would any combination vehicle. Refer to the information in Section 5 to learn how to check air brakes on combination vehicles.

## Section 8: Tank Vehicles

This section is for drivers who drive tank vehicles

This section has information needed to pass the CDL knowledge test for driving a tank vehicle. You should also study Sections 2, 5, and 6. A tank vehicle is used to carry any liquids or gaseous materials in tanks.

Before loading, unloading, or driving a tank vehicle, inspect the vehicle. Make sure that the vehicle is safe to carry the liquid or gaseous material and is safe to drive.

*Tank Endorsement Needed*

### Tank Vehicle Defined

A tank vehicle includes any commercial vehicle which has fixed tanks (including collapsible containers, also called “bladder bags”) or that carry portable tanks of 1,000 gallons or more capacity. (VC §15210[k]) Portable tanks are bulk containers which are not permanently attached to a vehicle. The product is loaded or unloaded while the portable tanks are off the vehicle, they are then loaded on a vehicle for transportation.

A tank vehicle also includes any fixed tank in excess of 119 gallons mounted on any vehicle or vehicle combination which requires a CDL or placards. (Example, a pickup transporting a 120 gallon fixed tank containing diesel requires a commercial Class C with Tank/HazMat endorsements. However, no CDL is needed for a 25,999 GVWR 2-axle truck with a 3000 gallon water tank pulling a trailer less than 10,000 lbs. GVWR.)

### Inspecting Tank Vehicles

Tank vehicles have special items that you need to check. Tank vehicles come in many types and sizes. You need to check the vehicle’s operator’s manual to make sure you know how to inspect your tank vehicle.

On all tank vehicles, the most important item to check for is leaks. Check under and around the vehicle for signs of any leaking. Don’t carry liquids or gases in a leaking tank. In general, check the following:

- The tank’s body or shell for dents or leaks.
- The intake, discharge, and cut-off valves. Make sure the valves are in the closed position except when loading or unloading.
- The pipes, connections, and hoses for leaks especially around joints.
- The manhole covers and vents. Make sure the covers have gaskets and they closed correctly. Keep the vents clear so they work correctly.
- The special purpose equipment. If your vehicle has any of the following equipment, make sure it works:
  - vapor recovery systems
  - grounding and bonding cables
  - emergency shut-off systems
  - built-in fire extinguisher and/or system

Make sure you know how to operate your special equipment.

- Check the emergency equipment required for your vehicle. Find out what equipment you are required to carry and make sure you have it and it works.

## Driving Tank Vehicles

### Speeding In A Tank Vehicle

If you are driving a tank vehicle containing more than 500 gallons of flammable liquid, which is subject to VC §34000, faster than the speed limit allowed, you are subject to a \$500 fine for a first offense. Stiffer penalties apply for a second or subsequent offense.

### Hours Of Service In A Tank Vehicle

The maximum driving time within a work period is 10 hours for drivers of tank vehicles with a capacity greater than 500 gallons when transporting flammable liquid. (49 CFR 395.1)

Liquids in bulk are transported in tanks, mounted on trucks, semitrailers, or full trailers. Transporting liquids, including liquefied gases, in tanks requires special skills because of the high center of gravity and the liquid surge of the cargo. Transit mix trucks and cement mixers are considered tank vehicles for purposes of a California CDL.

### High Center Of Gravity

High center of gravity means that the load is carried high up off the road. This makes the vehicle top-heavy and easy to roll over. Tankers often roll over. Tests have shown that tankers can turn over even at the cautionary speeds posted for curves. You should drive on highway curves or onramp/offramp curves well below the posted speeds.

### Liquid Surge

Liquid surge results from movement of the liquid in partially filled tanks. For example, when coming to a stop, the liquid will surge back and forth. When the wave hits the end of the tank, it tends to push the truck in the direction the wave is moving. If the truck is on a slippery surface such as ice, the wave can shove a stopped truck into an intersection. The

driver of a tanker must be very familiar with the handling of the vehicle.

### Bulkheads

Some large tanks are divided into several smaller tanks by bulkheads. Bulkheads are liquid-tight separators between compartments inside the tank. When loading and unloading the smaller tanks, the driver must pay special attention to weight distribution. Do not put too much weight on the front or rear of the vehicle.

### Baffled Tanks

Some tanks have compartments in them that have holes. If the compartment walls have holes in them, they are called **baffles**. Baffles let the liquid flow through and help control the forward and backward liquid surge. However, side to side surge can still occur which can cause a rollover. Drive slowly and be careful in taking curves or making sharp turns with a partially or fully loaded tanker.

### Unbaffled Tanks

**Smooth bore** (or unbaffled) tankers have nothing inside to slow down the flow of the liquid. Therefore, forward and back surge is very strong. Smooth bore tanks are usually those that transport food products such as milk. Sanitation regulations rule out the use of baffles because of the difficulty in cleaning the inside of the tank. Corrosive liquids are also routinely transported in smooth bore tanks. Be extremely cautious (slow and careful) when driving smooth bore tanks, especially when starting and stopping.

### Outage

Never load a cargo tank totally full. Liquids expand as they warm and you must leave room for the expanding liquid. This is called outage. Since different liquids expand by different amounts, they require different amounts of outage. You must know the outage requirement of your load when transporting liquids in bulk.

## How Much To Load?

A full tank of dense liquid such as some acids may exceed legal weight limits. For that reason, you may often only partially fill tanks with heavy liquids. The amount of liquid to load into a tank depends on:

- The amount the liquid will expand in transit.
- The weight of the liquid.
- Legal weight limits.
- Temperature of the load.

## Safe Driving Rules

In order to drive tank vehicles safely, you must remember to follow all the safe driving rules. A few of these rules are:

- Drive smoothly. Because of the high center of gravity and the surge of the liquid, you must start, slow, and stop very smoothly. Also, make smooth turns and lane changes.
- If you must make a quick stop to avoid an accident, use controlled or stab braking. (See Section 2.) Remember that if you steer quickly while braking, your vehicle may roll over.
- Slow down before curves and accelerate slightly when coming out of the curve. The posted *and/or advisory* speed for a curve may be too fast for a tank vehicle.
- Keep in mind how much space you need to stop your vehicle. Remember that wet roads double the normal stopping distance. Empty tank vehicles may take longer to stop than full ones.
- Don't over steer, over accelerate, or over brake. If you do, your vehicle may skid. On tank trailers, if your drive wheels or trailer wheels begin to skid your vehicle may jackknife. When any vehicle starts to skid, you must take action to restore traction to the wheels.

Pass your CDL!



Visit now!

## Section 9: Hazardous Materials/Wastes

This section is for drivers who need a HAZMAT endorsement

**NOTE:** To ensure public safety, DMV examiners will not conduct commercial driving tests in vehicles displaying vehicle placards per VC §27903. This includes vehicles carrying hazardous materials and/or wastes and vehicles which have not been purged of their hazardous cargo. VC §15278(a)(4) requires a HAZMAT endorsement for those who drive a vehicle requiring placards.

### *HAZMAT Endorsement Needed*

**NOTE: Your CDL tests will be based on your knowledge of federal transportation requirements. Text preceded by “California” refers to state (non-federal) requirements which also apply when driving in California. The state requirements are strictly enforced.**

Hazardous materials and wastes including radioactive materials pose a risk to health, safety, and property during transportation. The Hazardous Materials Table lists materials considered hazardous. The rules (Title 49 Code of Federal Regulations [CFR]) sometimes require diamond shaped, square-on-point, warning signs on vehicles transporting certain types or quantities of hazardous materials. These signs are called placards.

You must have a commercial driver license with a HAZMAT endorsement before driving vehicles carrying hazardous materials which require placards. To get the endorsement, you must pass a written test in English about the hazardous materials transportation rules. By studying this section you will learn to recognize hazardous cargo, to contain the material, and to communicate the danger.

This handbook tells all you need to know to pass the written test. However, this is only a beginning.

You can learn more by reading the rules in state and federal regulations. You can also learn more by attending training courses offered by your employer or others. Every employee who transports hazardous materials must receive training to recognize and identify hazardous materials and become familiar with HAZMAT requirements. (49 CFR 172.702, 172.704, and 13 CCR 1161.7) Government and industry publishers sell copies of the regulations. Union or company offices often have copies of the rules for driver use. Find out where you can get your own copy to use on the job.

In addition to the general HazMat training requirements (49 CFR 172.700–172.706) and repeated training every three years, drivers are also required to be trained in function- and commodity-specific requirements (e.g., flammable cryogenic liquids or Highway Route Controlled Quantities [HRCQ] of radioactive materials.)

**Permits.** A permit or route restriction may be required to transport some classifications and quantities of hazardous materials. Contact the California Highway Patrol and the U. S. Department of Transportation for information. Permits and registrations may also be required for hazardous waste and medical waste transportation. Contact the Department of Toxic Substances Control and the Department of Health Services respectively, for information.

If you apply for an original or renewal HazMat endorsement, you must undergo a Transportation Security Administration (TSA) federal security threat assessment (background records check). You start the TSA background records check after you apply for your CDL at DMV, successfully complete all appropriate law tests, and submit a valid medical form. You must

submit fingerprints, a fee, and any additional required information to one of TSA's designated agents. You must also provide the TSA agent with a copy of your CDL permit and one of the following identification documents:

- A California DL/ID card
- An out-of-state DL
- Your CDL permit accompanied by a DMV photo receipt

For a list of TSA agent sites, go online at [www.hazprints.com](http://www.hazprints.com) or call 1-877-429-7746.

### California Hazardous Material Transportation License

Every motor carrier who transports the following hazardous materials in California must have a Hazardous Materials Transportation License issued by the CHP (VC §32000.5):

- Hazardous materials shipments (unless specifically excepted) for which the display of placards is required per VC §27903.
- Hazardous materials shipments in excess of 500 lbs., transported for a fee, which would require placarding if shipped in greater amounts in the same manner.

A valid legible copy of the carrier's Hazardous Materials Transportation License must be carried in the vehicle and be presented to any peace officer upon request. (13 CCR 1160.3[g] [2])

This is in addition to the federal HazMat registration that may be required under 49 CFR 107.601.

### Intent Of The Regulations

The 49 CFR Hazardous Materials Regulations (HMR) govern the safety aspects of transportation. They include requirements for classification of materials, packaging (including manufacture, continuing qualification, and maintenance), hazard communication (i.e., package marking, labeling, placarding, and shipping documentation), transportation, handling, HAZMAT employee training, and incident reporting.

### Packaging and Securement

Many hazardous materials can injure or kill on contact. In order to protect drivers and others, the rules tell shippers how to package safely. Loading, securement, and segregation rules tell drivers how to load, transport, and unload their cargo.

### Communicate The Risk

Shippers must warn drivers and others about a material's hazardous qualities. They must put warning labels and markings on packages and describe materials on the shipping paper in a way that clearly warns of the risk. There are rules for drivers too. If there is an accident or a leak, the driver must warn others of danger. Placards and package markings are another way to communicate the risk.

### Assuring Safe Drivers And Equipment

Drivers must pass a written test about transporting hazardous materials or wastes. To pass the test, drivers must know how to:

- Recognize shipments of hazardous materials or wastes.
- Safely load shipments.
- Correctly placard.
- Safely transport shipments.

You should, and are often required to, inspect your vehicle before and during each trip. Law enforcement officers may stop and inspect your vehicle. They may check shipping papers and your driver license for a HAZMAT endorsement.

### Transporting Hazardous Materials

#### The shipper:

- Sends the products from one place to another by truck, railroad, ship, or airplane.
- Uses the hazardous materials regulations to decide the product's:
  - proper shipping name



- hazard class and division
- identification number (ID)
- correct packaging
- correct label(s) and markings
- correct placard(s)
- Packages the materials, labels and marks the package, prepares the shipping paper and emergency response information, and supplies the placards.
- Certifies on a shipping paper that the shipment has been prepared according to the rules, unless a private carrier is used or the carrier supplies the cargo tanks.

#### The carrier:

- Takes the shipment from the shipper to its destination.
- Before transporting, checks that the shipper correctly named, labeled, and marked the shipment.
- Refuses improper shipments.
- Reports collisions and incidents involving hazardous materials or wastes to the proper government agency.

#### The driver:

- Makesuretheshipperhasidentified,marked, and labeled the product correctly.
- Refuses leaking packages.
- Refuses shipments not properly prepared.
- Attaches placards when loading, if needed.
- Ensures the appropriate product identification number(s) are displayed on transport vehicles, when required.
- Safely transports the shipment without delay.
- Follows all special rules about transporting hazardous materials or wastes.
- Keeps hazardous materials shipping papers, including the emergency response information, in order and in the proper place.

## Communication Rules

Some words and phrases have special meanings when talking about hazardous materials. The

meanings may differ from common use. Learn the words printed in **bold** below. The meanings of other important words are in the glossary.

### Definitions

A material's hazard class reflects the risks associated with it. Appendix A on pages 110 and 111 tells the exact meaning of each hazard class. There are 9 different hazard classes. Some classes have subdivisions to better define the hazard.

#### **Class 1—Explosives**

Division 1.1—Explosives with a mass explosion hazard

Division 1.2—Explosives with a projection hazard

Division 1.3—Explosives with predominantly a fire hazard

Division 1.4—Explosives with minor explosion hazard

Division 1.5—Very insensitive explosives

Division 1.6—Extremely insensitive explosive articles

#### **Class 2—Gases**

Division 2.1—Flammable gases

Division 2.2—Nonflammable gases

Division 2.3—Poison gases

Division 2.4—Corrosive gases (Canada only)

#### **Class 3—Flammable Liquids**

#### **Class 4—Flammable Solids,**

#### **Spontaneously Combustible Materials, and Materials that are Dangerous When Wet**

Division 4.1—Flammable solids

Division 4.2—Spontaneously combustible materials

Division 4.3—Materials that are dangerous when wet

#### **Class 5—Oxidizing Materials**

Division 5.1—Oxidizers

Division 5.2—Organic peroxides

#### **Class 6—Poisonous and Etiologic (infectious) materials**

Division 6.1—Poisonous materials

Division 6.2—Infectious substance (etiologic)

**Class 7—Radioactive Materials****Class 8—Corrosive Materials****Class 9—Miscellaneous Hazardous Materials**

In addition to the above classifications, materials meeting the 49 CFR definition of a “combustible liquid” and do not meet the definition of any other hazard class, hazardous substance, or marine pollutant are only regulated domestically when shipped in a bulk package. Also, specified hazardous materials may be transported as Other Regulated Material-D (ORM-D) (e.g., “a consumer commodity”).

**Shipping Papers**

A proper shipping paper is a document or paper containing the hazardous materials information required by regulations. Shipping orders, bills of lading, and manifests are all shipping papers. Shippers show a material’s proper shipping name, hazard class or division, ID number, and packing group on the shipping paper. After an accident or hazardous materials incident, you may be unable to speak when help arrives. Fire fighters and police must know the hazards involved in order to prevent more damage or injury. Your life, and the lives of others, may depend on their quickly finding the shipping papers and emergency response information for hazardous cargo. For that reason the rules require:

- Shippers to describe shipments correctly on shipping papers and include an emergency response telephone number on shipping papers.
- Carriers and drivers to put tabs on shipping papers related to hazardous materials or wastes, or keep them on top of other shipping papers. Required emergency response information must be kept in the same manner as shipping papers.
- Drivers to keep shipping papers for hazardous cargo in a pouch on the driver’s door, or otherwise, in clear view within reach while the seat belt is fastened for driving, and on the driver’s seat or pouch on the driver’s door when away from the vehicle.

**Labels, Placards, And Markings**

**Labels** at least four inches by four inches in size are applied to the outside of hazardous materials shipping packages near the shipping name. (**NOTE:** Labels on packages prepared under United Nations Recommendations on the Transportation of Dangerous Goods may be smaller than four inches.) These labels identify the primary and secondary hazard specific to the material being transported and give warning information about handling precautions in case of an emergency. If the diamond label will not fit on the package, shippers will put the label on a tag. For example, compressed gas cylinders that will not hold a label will have tags or decals. Labels look like the example in Figure 9-1. See the charts starting on page 112.

“**Marking**” a non-bulk package refers to applying the required information to the outside of shipping containers (e.g., proper shipping name, ID number, consignee/consignor, and required instructions). For bulk packagings

Figure 9-1 Example of Labeled Package

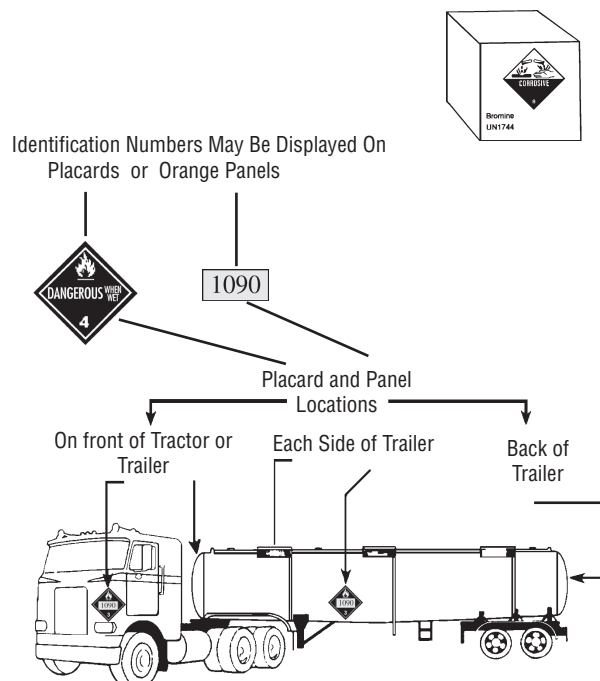

Figure 9-2 Placard and Panel Locations

and transport vehicles, when required, the ID numbers must be displayed on orange panels, white squares-on-point, or across the middle of the appropriate placard, as appropriate.

**Placards** are signs used to warn others of hazardous cargo and are put on the outside of a vehicle to show the hazard class of the cargo. A placarded vehicle must have at least 4 placards representing the applicable hazard. They are attached to each side and each end of the vehicle, as shown in Figure 9-2. Placards must be readable from all four directions. There are 22 DOT specification placards. They are 10 3/4 inches square, turned upright on a point, in a diamond shape. Cargo tanks and other bulk packaging show the ID number of their contents on placards, orange rectangular panels, or plain white square-on-point configurations having the same dimensions as placards.

For hazardous materials for which placards are not specified, ID numbers may be displayed on orange panels or plain white square-on-point configurations.

Safety signs such as “Drive Safely” and any other sign displayed as a square-on-point are not allowed.

### Regulated Products Lists

There are three main lists used by shippers, carriers, and drivers to identify hazardous

materials. These can be found in Title 49 CFR, Section 172.101. Before transporting an unfamiliar product, look for its name on all lists. Some products are on all lists; others may be on only one. These are the lists to check:

- Hazardous Materials Table.
- List of Hazardous Substances and Reportable Quantities.
- List of Marine Pollutants.

**The Hazardous Materials Table (See Figure 9-3).** Column 1 of the Hazardous Materials Table tells which mode of transportation the entry affects. The next five columns show each material’s shipping name, hazard class or division, ID number, packaging group, and required labels. Five different symbols may appear in Column 1 of the table.

- **+** Shows the shipping name and hazard class to use, even if the product does not match the hazard class definition.
- **A** Means the entry is subject to the regulations only when offered or intended for transport by air, unless it is also a hazardous substance or hazardous waste.
- **D** Means the entry applies to domestic transportation but may be inappropriate for international shipment.
- **G** Means the entry contains a proper shipping name for which one or more

Figure 9-3. Part of the Hazardous Materials Table

§172.101 Hazardous Materials Table									
Symbols	Hazardous materials descriptions and proper shipping names	Hazard class or Division	Identification Numbers	Packing Group	Label(s) required (if not excepted)	Special provisions	(8) Packaging authorizations (§173.***)		
							Excep-tions	Non-bulk pack-aging	Bulk pack-aging
(1)	(2)	(3)	(4)	(5)	(6)	(7)	(8A)	(8B)	(8C)
—	Poisonous, solids, self heating, n.o.s....	6.1	UN3124	I	POISON, SPONTANEOUSLY COMBUSTIBLE	A5_	None	211	241

hazardous materials technical names must be entered in parenthesis, in addition to the proper shipping name.

- **I** Means the entry applies to international transportation. An alternate proper shipping name may be selected when only domestic transportation is involved.
- **W** Means the entry is subject to the regulations only when offered or intended for transport by water, unless it is a hazardous substance or waste or a marine pollutant.

Column 2 shows proper shipping names and descriptions of regulated materials. Entries are in alphabetical order. Use the name of the material on the shipping paper—it must be the proper shipping name. The Hazardous Materials Table shows proper shipping names in regular type. The entries that are in *italics* are not proper shipping names. A shipper may only use them in addition to the proper shipping names.

Column 3 shows each material's hazard class or division, or the word "Forbidden." Never transport a material that is forbidden. A material's hazard class or division is the key to using placards. You can decide which placards to use if you know these five things:

- Material's hazard class or division.
- Special provisions.
- Amount being shipped.
- Total amount of weight of all hazard classes loaded on your vehicle.
- Type of packaging (i.e., drum versus cargo tank)

Column 4 shows each material's ID number. ID numbers are preceded by the letters "UN" or "NA." The letters "NA" are associated with proper shipping names that are only used within the United States and to and from Canada. The identification number must appear on the shipping paper as part of the shipping description and also appear on the package. It also must appear on cargo tanks and other bulk packaging.

The number is used by police and fire crews to quickly identify the material after an accident.

Column 5 shows each material's packing group. Packing groups indicate the degree of danger presented by the material. The shipper is responsible for determining the appropriate packing group.

**NOTE:** Classes 2, 7, and ORM-D materials do not have packing groups assigned.

Column 6 shows the label(s) shippers must put on packages of hazardous materials. Where the word "none" is shown, no label is needed. The rules require more than one label for some products.

Column 7 shows special provisions which may be required by 49 CFR 172.102 for the item being shipped. These special provisions may require specific additional and/or alternate requirements (i.e., packaging, handling, marking, etc.).

Column 8 is a three-part column showing the section numbers covering the packaging requirements for each hazardous material.

**Note:** Columns 9 and 10 do not apply to highway transportation.

**Appendix A, §172.101—The List of Hazardous Substances and Reportable Quantities (RQ).** The Department of Transportation (DOT) and the Environmental Protection Agency (EPA) monitor spills of hazardous substances, which are named in the List of Hazardous Substances and Reportable Quantities. Any spill of an RQ hazardous substance must be reported by telephone. Refer to page 109 for additional information.

This list shows each product's RQ. Carriers must report spills from packages containing a quantity equal to or greater than the RQ for that product. The shipper identifies these materials as hazardous substances by entering the letters "RQ" on the shipping paper either before or after the basic shipping description.



## Shipping Paper Item Descriptions

If the shipping paper describes both hazardous and nonhazardous products, the hazardous materials must be either: (1) described first, (2) highlighted in a contrasting color, or (3) identified by an “X” placed before the shipping name in a column captioned “HM.” The letters RQ may be used instead of X if the shipment is a reportable quantity.

The basic description of a hazardous product includes the proper shipping name, hazard class or division, ID number, and the packing group, if any, in that order. Any additional information such as customer item number, product code(s), trade names, etc., must be placed after the basic shipping description. Shipping name, hazard class, and ID number must not be abbreviated unless specifically authorized in the hazardous materials regulations. The description must also show:

- The total quantity and unit of measure.
- The letters RQ if a reportable quantity.
- If the letters RQ appear, the name of the hazardous substance.
- For “n.o.s.” and generic descriptions, the technical name of the hazardous material when indicated by a “G” in column 1 of the Hazardous Materials Table.

Total quantity can appear before or after the basic description. Packaging type and the unit of measurement may be abbreviated. For example:

10 ctns. paint, 3, UN 1263, PG II, 500 lbs.

The shipper of hazardous waste must put the word WASTE before the name of the material on the hazardous waste manifest. For example:

Waste Acetone, 3, UN 1090, PG II

A nonhazardous material must not be described by using a hazard class or an ID number.

Technical names are required for n.o.s. and other generic descriptions. If a material is described on a shipping paper by proper shipping name, the

technical name of the hazardous material must be entered in parentheses. For example:

Corrosive liquid, n.o.s. (Caprylyl chloride),  
8, UN1760, PG I

**OR**

Corrosive liquid, n.o.s., 8, UN1760, PG I,  
(Caprylyl chloride)

The same requirement applies to shipping descriptions for poisonous (toxic) materials if the proper shipping name does not specifically identify the poisonous material by technical name.

If a hazardous material is a mixture or a solution of two or more hazardous materials, the technical names of at least two of the materials (those contributing the most hazard to the mixture) must be entered on the shipping paper. For example:

Flammable liquid, corrosive, n.o.s., 3  
UN2924, PG I, (contains Methanol, Potassium hydroxide)

## Shipper’s Certification

When the shipper packages a hazardous material, he or she certifies that the package has been prepared according to the regulations. The signed shipper’s certification appears on the original shipping paper. An exception is if a shipper is a private carrier transporting the company’s own product. Also, a shipper’s certification is not required on shipping papers used by the carrier, or when the material is offered by the primary carrier to a subsequent carrier. The glossary at the back of this handbook shows acceptable shipper certifications. Unless a package is clearly unsafe (leaking, etc.) accept the shipper’s certification concerning proper packaging. Some carriers have additional rules about transporting hazardous products. Follow your employer’s rules when accepting shipments.

## Package Markings And Labels

Shippers print other required information directly on the package, an attached label, or

a tag. The most important package marking is the proper shipping name of the hazardous material, which must be the same as the one on the shipping paper. When required, the shipper also will mark the package with the:

- Name and address of the shipper or consignee.
- Content's proper shipping name and ID number.
- Required hazard labels.

If the rules require it, the shipper also will put RQ or INHALATION HAZARD on the package. You will see markings or orientation arrows on cartons with liquid containers inside. The labels used will always reflect the hazard class of the product. If a package needs more than one label (e.g., to show a subsidiary hazard), the labels will be close together, near the proper shipping name.

Bulk packages containing material classed as MARINE POLLUTANTS must be marked on two opposing sides or two ends with the MARINE POLLUTANT mark, if not already labeled or placarded according to 49 CFR 172, Subparts E or F respectively.

## Recognizing Hazardous Materials

Learn to recognize shipments of hazardous materials. To find out if the shipment includes hazardous materials, look at the shipping paper. Does it have:

- An entry with a proper shipping name, hazard class, and ID number?
- A highlighted entry, or one with an X or RQ in the hazardous materials column?

Other clues suggesting hazardous materials:

- What business is the shipper in? Paint dealer? Chemical supply? Scientific supply house? Pest control or agricultural supplier? Explosives, munitions, or fireworks dealer?
- Are there tanks with diamond labels or placards on the premises?
- What type of package is being shipped?

Cylinders and drums are often used for hazardous materials shipments.

- Is a hazard class label, proper shipping name, or ID number on the package?
- Are there any handling precautions?

The laws and regulations regarding hazardous waste are found in the Health and Safety Code, Division 20, Chapter 6.5, and Title 22, California Code of Regulations, Division 4.5.

## Hazardous Waste Regulations

A person who transports hazardous wastes in the State of California must first obtain a Hazardous Waste Transporter Registration from the Department of Toxic Substances Control (DTSC). The registration certificate must be carried in the vehicle transporting the hazardous waste and shown upon demand to any DTSC representative, peace officer, local health officer, or public officer designated by DTSC.

There is an exemption for the transportation of up to 5 gallons or 50 lbs. of hazardous waste or 2.2 lbs. of extremely hazardous waste when transported by the producer of the waste to an authorized facility following specified guidelines.

The transporter of hazardous wastes is responsible for making sure that a Uniform Hazardous Waste Manifest is completed properly. The transporter must sign and date the manifest before removing the load of hazardous waste from the generator's facility. The manifest must be in his or her possession while transporting the hazardous waste and must be treated as a shipping paper. Hazardous wastes must only be delivered to another registered transporter or an authorized facility. The facility operator must sign and date the manifest when accepting the load of hazardous waste. If the hazardous waste cannot be delivered to the facility designated on the manifest, the transporter must contact the generator for instructions. The transporter must keep the copy of the manifest for a minimum of three years.

## Placarding

Attach the proper placards as you load the vehicle and before you drive it. You may move an improperly placarded vehicle only in an emergency to protect life or property.

Placards must be put on each side and each end of the vehicle (refer to Figure 9-2). Each placard must be:

- Easily seen from the direction it faces.
- Placed so that the words or numbers are level and read from left to right.
- At least 3 inches away from any other markings.
- Kept clear of attachments or devices such as ladders, doors, and tarpaulins.
- Kept clean and undamaged so that the color, format, and message are easily seen.

Use the hazard class, special provisions, the amount shipped, type of packaging, and the total weight of all hazardous materials on board to decide which placards you need.

First, check that the shipper is using the correct hazard class for the shipping paper and package label. If you are not familiar with the material, contact the shipper or your office.

There are two placard tables. Table 1 materials always require the use (display) of placards. Any amount of Table 2 materials in non-bulk packaging is required to be placarded if the material is subject to 49 CFR 172.505 (i.e., Poison-Inhalation Hazard or Dangerous When Wet) or if the amount transported in each vehicle is 1,001 lbs. or more, including the packaging. You may use DANGEROUS placards for each Table 2 hazard class when:

- You have two or more Table 2 hazard classes, requiring different placards, that total 1001 lbs. or more.
- You have not loaded 2,205 lbs. (1000 kg) or more of any Table 2 hazard class material at any one place. (You must use the specific placard for this material.)

If the words INHALATION HAZARD are on the shipping paper or package, you must display POISON GAS placards for Division 2.3 materials and POISON INHALATION HAZARD placards or POISON placards in addition to any other placards needed by the product's hazard class.

You do not need EXPLOSIVES 1.5, OXIDIZER, and DANGEROUS placards if a vehicle contains Division 1.1 or 1.2 explosives and is placarded with EXPLOSIVES 1.1 or 1.2. A NONFLAMMABLE GAS placard is not needed on a vehicle displaying a FLAMMABLE GAS or an OXYGEN placard.

## Loading And Unloading

Do all you can to protect hazardous materials containers. Don't use any tools which might damage containers or other packaging during loading. Don't use hooks.

- Before loading or unloading, set the parking brake and make sure the vehicle will not move.
- Many products are more hazardous in the heat. Load all hazardous materials away from heat sources.
- Watch for signs of leaking or damaged containers: LEAKS SPELL TROUBLE! Do not transport leaking packages. You, your truck, and others could be in danger.

Containers of Class 1 (explosives), Class 3 (flammable liquids), Class 4 (flammable solids), Class 5 (oxidizers), Class 8 (corrosives), Class 2 (gases), and Division 6.1 (poisons) must be braced to prevent movement of the packages during transportation.

**No smoking.** When loading hazardous materials, keep away from fires. Do not smoke or allow others to smoke near your vehicle. Never smoke within 25 feet of:

- Explosives.
- Oxidizers.
- Flammables.



PLACARD TABLE 2	
IF VEHICLE IS TO BE PLACARDED FOR...	USE PLACARD...
Explosives 1.1	1.1
Explosives 1.2	1.2
Explosives 1.3	1.3
Poison Gas	2.3
Dangerous When Wet	4.3
Poison	6.1 (PG I, inhalation hazard only)
Radioactive * (Radioactive Yellow III label only)	7

\* Radioactive placard also required for exclusive use shipments of low specific activity material (49 CFR §173.425).

PLACARD TABLE 2	
IF VEHICLE IS TO BE PLACARDED FOR...	USE PLACARD...
Explosives 1.4	1.4
Explosives 1.5	1.5
Explosives 1.6	1.6
Flammable gas	2.1
Nonflammable gas	2.2
Flammable	3
Combustible*	Combustible liquid
Flammable solid	4.1
Spontaneously combustible	4.2
Oxidizer	5.1
Organic peroxide	5.2
Poison	6.1 (PGI or II, other than PGI inhalation hazard)
Keep away from food	6.1 (PG III)
6.2	none
Corrosive	8
Class 9**	9 (not mandatory)
ORM-D	none

\* FLAMMABLE placard may be used in place of a COMBUSTIBLE placard on a cargo tank or portable tank.

\*\* Class 9 Placard is not required for domestic transportation.

**Secure against movement.** Make sure containers do not move around in transit. Brace them so they will not fall or bounce around. Use care when loading containers that have valves or other fittings.

Do not open any package between the points of origin and destination. You must never transfer hazardous products from one package to another. You may empty a cargo tank or intermodal (IM) specification portable tank, but do not empty any other package while it is on the vehicle,

except as necessary to fuel machinery or other vehicles.

**Cargo heater rules.** There are special cargo heater rules for loading these hazard classes:

- Explosives.
- Flammable liquid.
- Flammable gas.

The rules usually forbid use of cargo heaters, including automatic cargo heater/air conditioner units. Unless you have read all the related rules,

do not load the above products in a cargo space that has a heater. Use closed cargo space. You must load the following hazard classes into a closed cargo space. You cannot have overhang or a tailgate load for these hazard classes:

- Explosives.
- Flammable solids.
- Oxidizing materials.

## Precautions

**Explosives.** Before loading or unloading any explosive, turn your engine off. Then check the cargo space.

- Disable cargo heaters. Disconnect power sources and drain heater fuel tanks.
- There must be no sharp points that might damage cargo. Look for bolts, screws, nails, broken side panels, and broken floor boards.
- Use a floor lining when transporting Division 1.1, 1.2, or 1.3 explosives. The floors must be tight and the liner must not contain steel or iron.

Explosives need special handling to avoid damage. Never use hooks or other metal tools. Never drop, throw, or roll the shipment. Protect explosive packages from other cargo that might cause damage.

Do not transfer a Division 1.1, 1.2, or 1.3 explosive from one vehicle to another on a public roadway except in an emergency. If safety requires an emergency transfer, set out red warning reflectors, flags, or electric lanterns. You must warn other highway users.

Never transport damaged packages of explosives. Do not take a package that shows any dampness or an oily stain.

Do not transport Division 1.1 or 1.2 explosives in a triples combination or in vehicle combinations if:

- There is a marked or placarded cargo tank in the combination.
- The other vehicle in the combination contains the following:

- initiating explosive
- radioactive materials labeled YELLOW III
- Division 2.3 or 6.1 poisons
- hazardous materials in a portable tank, Spec 106A or 110A tank

**Corrosive liquids.** If loading by hand, load breakable containers of corrosive liquid one by one. Keep them right side up. Do not drop or roll the containers. Load them onto an even floor surface. Stack carboys only if the lower tiers can safely bear the weight of the upper tiers.

Do not load nitric acid above any other product. Cyanides or cyanide mixtures may not be loaded or stored with acids.

Load storage batteries so their liquid will not spill. Keep them right side up. Make sure other cargo will not fall against or short circuit them.

Never load corrosive liquids on the same transport vehicle with:

- Division 1.1, 1.2, 1.3, or 1.5 explosives. (Refer to Division 14 of the Vehicle Code for additional requirements.)
- Division 2.3, Zone A or 6.1, PG-I, Zone A, poisons.
- Division 4.2 materials.

Never load corrosive liquids near or above:

- Division 1.4 explosives
- Division 2.3, Zone B, gases
- Division 4.1 or 4.3 materials
- Division 5.1 or 5.2 materials

**Compressed gases, including Cryogenic liquids.** If your vehicle does not have racks to hold cylinders, the cargo space floor must be flat. The cylinders must be loaded securely to prevent overturning. They can be:

- Held upright or braced laying down flat.
- In racks attached to the vehicle.
- In boxes that will keep them from turning over.

**Poisons.** Never transport Division 2.3 (Poisonous

gas) or irritating materials in containers with interconnections. Never load a package labeled POISON or POISONOUS GAS in the driver's cab or sleeper.

Never load a package labeled POISON, POISON-INHALATION HAZARD, or POISONOUS GAS in the same vehicle with foodstuffs, feed, or any edible material intended for consumption by humans or animals, except as provided under 49 CFR 177.841(e). Packages with hazard labels or package markings displaying the text "PG III" may be loaded on the same vehicle with foodstuffs, feed, or other edible material if separated as specified in CFR 177.848(e)(3).

**Radioactive materials.** Some packages of radioactive materials bear a number called the "transport index." The shipper labels these packages Radioactive II or Radioactive III and prints the package's transport index on the label. Radiation surrounds each package, passing through all nearby packages. The transport index tells the degree of control needed during transportation. The total transport index of all packages in a single vehicle must not exceed 50.

If the cargo you are transporting requires placarding, you must have a HAZMAT endorsement.

**Mixed loads.** The rules require some products to be loaded separately. They cannot be put together in the same cargo space. Figures 9-5 and 9-6 list some examples of the incompatibilities. The regulations (The Segregation and Separation Chart) name other materials to keep apart.

**Inhalation hazards.** An INHALATION HAZARD is defined as a POISONOUS GAS or LIQUID of which a very small amount of gas or vapor of a liquid mixed with air is dangerous to life. Some inhalation hazards are classified as Division 2.3 (gas, poison by inhalation) while many others are classified under various other Divisions. These other materials are identified as POISON-INHALATION HAZARDS or

INHALATION HAZARDS per the special provisions codes, column 7, listed in the Hazardous Materials Table.

## Bulk Tanks

A bulk tank is intended primarily for carrying liquids, gases, or solids. Refer to the Glossary for more information. Cargo tanks remain on the vehicle when you load and unload them. Portable tanks are bulk containers which are not permanently attached to a vehicle. They are loaded or unloaded with the product while off the vehicle. Portable tanks are then put on a vehicle for transportation. **Exception:** IM specification portable tanks are authorized to be unloaded while attached to the transport vehicle.

There are many types of cargo tanks in use. The most common are MC 306 for liquids and MC 331 for gases.

## Markings

You must display the ID number of the contents of portable tanks, cargo tanks, and other bulk packagings (such as dump trucks). Product ID numbers are in column 4 of the Hazardous Materials Table. Those rules require black numbers on orange panels, placards, or white diamond-shaped backgrounds if no placards are required. Specification cargo tanks must show retest and inspection date markings.

Portable tanks must also show the lessee or owner's name. They must also display the shipping name of the contents on two opposing sides. The letters of the shipping name must be at least two inches tall on portable tanks with capacities of 1,000 gallons or more and one inch tall on portable tanks with capacities of less than 1,000 gallons. The ID number must appear on each side and each end of a portable tank or other bulk packaging that holds 1,000 gallons or more and on two opposing sides, if the portable tank holds less than 1,000 gallons.

The ID numbers must still be visible when the

**SEGREGATION TABLE FOR HAZARDOUS MATERIALS**

Class or Division	Notes	1.1 1.2	1.3	1.4	1.5	1.6	2.1	2.2	2.3 gas Zone A	2.3 gas other than Zone A	3	4.1	4.2	4.3	5.1	5.2	6.1 liquids PG I Zone A	7	8 liquids only
Explosives 1.1 and 1.2	A	*	*	*	*	*	X	X	X	X	X	X	X	X	X	X	X	X	X
Explosives 1.3		*	*	*	*	*	X		X	X	X		X	X	X	X	X		X
Explosives 1.4		*	*	*	*	*	O		O	O	O		O				O		O
Very insensitive explosives	A	*	*	*	*	*	X	X	X	X	X	X	X	X	X	X	X	X	X
Extremely insensitive explosives, 1.6		*	*	*	*	*													
Flammable gases 2.1		X	X	O	X				X	O							O	O	
Nontoxic, nonflammable gases, 2.2		X			X														
Poisonous gas Zone A, 2.3		X	X	O	X		X				X	X	X	X	X	X			X
Poisonous gas Zone B, 2.3		X	X	O	X		O				O	O	O	O	O	O			O
Flammable liquids, 3		X	X	O	X				X	O					O		X		
Flammable solids, 4.1		X			X				X	O							X		O
Spontaneous combust. materials, 4.2		X	X	O	X		X	O									X		X
Dangerous when wet materials, 4.3		X	X		X		X	O									X		O
Oxidizers, 5.1	A	X	X		X		X	O	O									X	O
Organic peroxides, 5.2		X	X		X		X	O									X		O
Poisonous liquids PG I Zone A, 6.1		X	X	O	X		O				X	X	X	X	X	X			X
Radioactive materials, 7		X			X		O												
Corrosive liquids, 8		X	X	O	X				X	O		O	X	O	O	O	X		

A blank space indicates that no restrictions apply.  
 X—materials may not be loaded, transported, or stored together in same transport vehicle.  
 O—materials may not be loaded, transported, or stored together in same transport vehicle unless separated in a manner that would prevent the materials from comingling in case of a leak. **NOTE:** Class 8 materials may not be loaded above Class 4 or Class 5 materials unless it is known that the mixture of contents will not cause a fire or dangerous evolution of heat or gas.  
 \*—segregation among different Class 1 materials is governed by the Compatibility Table for Class 1 (Explosive) Materials (Fig. 9-5).  
 A—nonwithstanding the requirements of the letter "X," ammonium nitrate fertilizer may be loaded or stored with Division 1.1 or 1.5 materials.

Figure 9-6

**COMPATIBILITY TABLE FOR CLASS 1 (EXPLOSIVE) MATERIALS**

Class or Division	A	B	C	D	E	F	G	H	J	K	L	N	S
A		X	X	X	X	X	X	X	X	X	X	X	X
B	X		X	X (4)	X	X	X	X	X	X	X	X	4/5
C	X	X		2	2	X	6	X	X	X	X	3	4/5
D	X	X (4)	2		2	X	6	X	X	X	X	3	4/5
E	X	X	2	2		X	6	X	X	X	X	3	4/5
F	X	X	X	X	X		X	X	X	X	X	X	4/5
G	X	X	6	6	6	X		X	X	X	X	X	4/5
H	X	X	X	X	X	X	X		X	X	X	X	4/5
J	X	X	X	X	X	X	X	X		X	X	X	4/5
K	X	X	X	X	X	X	X	X	X		X	X	4/5
L	X	X	X	X	X	X	X	X	X	X	1	X	X
N	X	X	3	3	3	X	X	X	X	X	X		4/5
S	X	4/5	4/5	4/5	4/5	4/5	4/5	4/5	4/5	4/5	X	4/5	

A blank space indicates that no restrictions apply.  
 X—explosives of different groups may not be carried on the same transport vehicle.  
 1—explosive from group L shall only be carried on the same transport vehicle with an identical explosive.  
 2—any combination of explosives from groups C, D, or E is assigned to group E.  
 3—any combination of explosives from groups C, D, or E with those in group N is assigned to group D.  
 4—refer to 49 CFR §177.835(g) when transporting detonators.  
 5—Div. 1.4 fireworks may not be loaded on same transport vehicle with Div. 1.1 or 1.2 (Class A) explosive material.

portable tank is on the motor vehicle. If they are not visible, you must display the ID number on both sides and ends of the motor vehicle.

### **Loading**

The loading and unloading of a cargo tank must be attended. The person overseeing the loading or unloading must be alert and:

- Have a clear view of the cargo tank.
- Be within 25 feet of the tank.
- Be aware of the hazards.
- Know the procedures to follow in an emergency.
- Be authorized to move the cargo tank and able to do so.

Close all manholes and valves before moving a tank carrying hazardous materials. It does not matter how small the amount in the tank or how short the distance. Manholes and valves must not leak.

### **Flammable Liquids**

Turn off your engine before loading or unloading any flammable liquid. Only run the engine if it is needed to operate a pump. Ground a cargo tank correctly before filling it through an open filling hole. Ground the tank before opening the filling hole, and maintain the ground until after closing the filling hole.

### **Compressed Gas**

Keep liquid discharge valves on a compressed gas tank closed except when loading and unloading. Unless your engine must run a pump for product transfer, turn it off when loading or unloading. If you use the engine, turn it off after material delivery, before unhooking the hose.

### **Chlorine Cargo**

Unhook all loading/unloading connections before coupling, uncoupling, or moving a chlorine cargo tank. Always chock trailers and semitrailers to prevent motion after the trailers are dropped.

## **Federal Driving And Parking Rules**

### **Division 1.1, 1.2, or 1.3 Explosives**

Do not park with Division 1.1, 1.2, or 1.3 explosives within 5 feet of the traveled part of the road. Except for short periods of time needed for vehicle operation necessities (i.e., fueling), do not park within 300 feet of:

- A bridge, tunnel, or building.
- A place where people gather.
- An open fire.

If you must park to do your job, only do so briefly.

Do not park on private property unless the owner is aware of the danger. You must always watch the parked vehicle. You may let someone else watch it for you only if your vehicle is on the:

- Shipper's property.
- Carrier's property.
- Consignee's property.

Vehicles may be parked unattended in a safe haven. A safe haven is a government approved place for parking unattended vehicles loaded with explosives. Designation of authorized safe havens are usually made by local authorities. In California, safe havens are designated by the CHP and referred to as "safe parking places."

### **Other Placarded Vehicles**

You may park a placarded vehicle (not laden with explosives) within 5 feet of the traveled part of the road if your work requires it. You may park for only a brief time. Someone must always watch a vehicle parked with hazardous materials on a public roadway or shoulder. Do not uncouple or leave a trailer with hazardous materials on a public street. Do not park within 300 feet of an open fire.

## Attending Parked Vehicles

The person attending a placarded vehicle must:

- Be in the vehicle, awake, and not in the sleeper berth.
- Within 100 feet of the vehicle and have it within clear view.
- Be aware of the hazards.
- Know what to do in emergencies.
- Be able to move the vehicle, if necessary.

Drivers of vehicles required to be placarded or marked per 49 CFR 177.823 (VC §27903) must also be driven and parked in compliance with state and local requirements (49 CFR 397.3).

## Transporting Explosives In California

When transporting any amount of Division 1.1, 1.2, 1.3, or 1.6 EXPLOSIVES or a combination of any of these explosives together with a Division 1.5 EXPLOSIVE (blasting agent) as a delivery service or “for hire,” you must use special routes, safe stopping places, safe parking places, and mandatory vehicle inspection locations prescribed by the CHP. When transporting more than 1000 lbs. of these explosives in private carriage (other than as a delivery service) the same requirements apply.

## Transporting Inhalation Hazards In California

Shipments of materials designated as “Poison Inhalation Hazard,” “Toxic Inhalation Hazard,” or “Inhalation Hazard” per 49 CFR 172.203, when transported in bulk packagings (49 CFR 171.8), must also be transported using special routes, safe stopping places, and mandatory vehicle inspection locations prescribed by the CHP for these materials.

## Transporting Radioactive Materials In California

There are also specific routes prescribed by the CHP for “Highway Route Controlled Quantity (HRCQ)” and “Radioactive Materials (RAM)” shipments.

Drivers must have in their possession a copy of the routes applicable to their shipment when transporting these materials. The routes, stopping places, and inspection locations are contained in 13 CCR 1150-1152.8 (Explosives), 1155-1157.20 (IH), and 1158-1159 (HRCQ). These requirements are also published by the CHP. Motor carriers may receive these publications, including revisions, by indicating their request on the APPLICATION FOR HAZARDOUS MATERIAL TRANSPORTATION LICENSE or by contacting the Commercial Vehicle Section, Routing Coordinator at (916) 327-3310.

## California General Hazardous Materials Routing Requirement

The following general routing and parking restrictions (VC §31303) apply to hazardous material and hazardous waste shipments for which the display of vehicle placards and/or markings are required per VC §27903 (*except shipments subject to, and in conformance with, special routing and related requirements*):

- Unless specifically restricted or prohibited (VC §31304), use state or interstate highways which offer the least transit time whenever possible.
- Avoid, whenever practicable, congested highways, places where crowds are assembled, and residence districts. (VC §515)
- Deviation from designated routes is not excusable on the basis of operating convenience.
- Do not leave a loaded vehicle unattended or parked overnight in a residence district.
- Except for specifically restricted or prohibited highways, other highways may

be used that provide necessary access for pickup or delivery consistent with safe vehicle operation.

- Highways which provide reasonable access to fuel, repairs, rest, or food facilities that are designed to and intended for commercial vehicle parking, when that access is safe and when the facility is within one-half mile of the points of exit and/or entry to the designated route.
- Restricted or prohibited routes may only be used when no other lawful alternative exists. The CHP also publishes a list of restricted or prohibited highways. (VC §31304) Copies of this list may be obtained by contacting the Commercial Vehicle Section, Routing Coordinator at (916) 327-3310.

### Flammable Cargo Restrictions

You might break down in a place where you must use stopped vehicle signals. Use reflective triangles or red electric lights. Do not use burning signals such as flares or fusees around a:

- Tank used for flammable liquids or flammable gas whether loaded or empty.
- Vehicle loaded with the following:
  - Division 1.1, 1.2, or 1.3 explosives.
  - Class 3 materials.
  - Division 2.1 flammable gas.

Do not smoke within 25 feet of a placarded tank used for flammable liquids or gases. Also, do not smoke or carry a lighted cigarette, cigar, or pipe within 25 feet of any vehicle which contains:

- Class 1 (explosives).
- Class 5.1 (oxidizers).
- Class 3 (flammables, including tanks containing residue).

### Fueling Restrictions

Turn off your engine before fueling a placarded vehicle. Someone must always be at the nozzle controlling fuel flow.

### Fire Extinguishers

The power unit of placarded vehicles must have a fire extinguisher with a UL rating of at least 10 B:C or more. In California, tank vehicles or combinations of tank vehicles used to transport flammable or combustible liquids shall be equipped with at least one fire extinguisher rated not less than 20 B:C, serviced annually.

### Tire Checks

The driver of a placarded vehicle with dual tires must make sure the tires are properly inflated. Check at the start of each trip and when you park. Check the tires every 2 hours or 100 miles, whichever is less. The only acceptable way to check tire pressure is to use a tire pressure gauge.

Do not drive with a tire that is leaking or flat except to the nearest safe place to fix it. Remove any overheated tire. Place it a safe distance from your vehicle. Do not drive until you have corrected the cause of overheating. Always follow the rules about parking and attending placarded vehicles. They apply even when checking, repairing, or replacing tires.

### Where To Keep Shipping Papers

Do not accept a hazardous materials shipment without a properly prepared shipping paper. A shipping paper for hazardous materials must always be easily recognized. Other people must be able to find it quickly in the event of an accident.

- Clearly distinguish hazardous materials shipping papers from others by tabbing them or keeping them on top of the stack of papers.
- When you are behind the wheel, keep shipping papers within your reach (with your seat belt on), or in a pouch on the driver's door. They must be easily seen by someone entering the cab.

- When not behind the wheel, leave the shipping papers in the driver's door pouch or on the driver's seat.
- Emergency response information must be kept in the same manner as the shipping paper.

### **Papers Needed For Division 1.1, 1.2, or 1.3 Explosives**

A carrier must give each driver transporting Division 1.1, 1.2, or 1.3 explosives a copy of the Federal Motor Carrier Safety Regulation (FMCSR) part 397. The carrier must also give written instructions on what to do in the event of an accident or delay. The written instructions must include the:

- Names and telephone numbers of people to contact (including carrier agents or shippers).
- Nature of the explosives transported.
- Precautions to take in emergencies such as fires, collisions, or leaks.

You must sign a receipt for these documents and be familiar with, and have in your possession while driving, the:

- Shipping papers.
- Written emergency instructions.
- Written route plan.
- Copy of FMCSR part 397.

### **Special Equipment For Chlorine**

A driver transporting chlorine in cargo tanks must have an approved gas mask on the cargo tank. The driver must also have an emergency kit for controlling leaks in dome cover plate fittings on the cargo tank.

### **Railroad Crossings**

**Stop before crossing a railroad if your vehicle:**

- Is marked or placarded. (49 CFR 392.10)
- Carries any amount of chlorine. (49 CFR 392.10)

- Has cargo tanks, whether loaded or empty, used for hazardous materials or wastes. (49 CFR 392.10)

You must stop 15 to 50 feet before the nearest rail. Proceed only when you are sure no train is coming. Do not shift gears while crossing the tracks.

## **Dealing With Emergencies**

The Department of Transportation publishes an *Emergency Response Guidebook* for fire fighters, police, and industry personnel. The guidebook tells them what to do first to protect themselves and the public from hazardous materials or wastes. The guidebook is indexed by shipping name and hazardous material ID number. Emergency personnel look for these things on the shipping paper. It is important that the proper shipping name, ID number, label, and placards used are correct.

### **Emergency Response Guidebook (ERG)**

**As a professional driver, your job at the accident scene is to:**

- Keep people away from the area.
- Limit the spread of material, only if you are trained to do so.
- Communicate the danger to emergency response personnel.
- Provide emergency responders with the shipping papers and emergency response information.

### **Vehicle Crashes**

**Follow this checklist:**

1. Check to see that your driving partner is OK.
2. Keep shipping papers with you.
3. Keep people far away and upwind.
4. Warn others of the danger.
5. Send for help.
6. Follow your employer's instructions.



## Fires

You might have to control minor fires involving your vehicle on the road. However, unless you have the training and equipment to do so safely, do not fight hazardous materials fires. Dealing with hazardous materials fires requires special training and protective gear.

When you discover a fire, send someone or call 9-1-1 for help. You may use the fire extinguisher to keep minor vehicle fires from spreading to cargo before fire fighters arrive. You should feel trailer doors to see if they are hot before opening them. If hot, you may have a cargo fire and should not open the doors. Opening doors lets air in and may make the fire flare up. Without air many fires only smolder until firemen arrive, doing less damage. If your cargo is already on fire, it is not safe to fight the fire. Keep the shipping papers with you to give to emergency personnel as soon as they arrive. Warn other people of the danger and keep them away.

## Leaks

If you discover a cargo leak, identify the material by using shipping papers, labels, package location in trailer, and any other clue. Do not touch any leaking material. Many people, under the stress of handling an accident or leak, forget and injure themselves this way. Do not attempt to identify materials or find the source of a leak by smell. Many toxic gases destroy one's sense of smell. They can injure or kill you without smell. Do not eat, drink, or smoke around a leak or spill.

If no material is spilling from your vehicle, you may drive to the closest area where you can get help. Never move your vehicle if doing so will spread contamination or damage the vehicle. Keep downwind and away from roadside rest stops, truck stops, cafes, and businesses. Never try to repack leaking containers unless you have the training and equipment to repair leaks safely. Call your dispatcher or supervisor for instructions and, if needed, emergency personnel.

If hazardous material is spilling from your vehicle, you may move off the road and away from places where people gather, if doing so serves safety. Only move your vehicle if you can do so without danger to yourself or others.

Never continue driving with hazardous materials leaking from your vehicle even to find a phone booth, truck stop, help, or similar reason. Remember that the carrier pays for the cleanup of contaminated parking lots, roadways, and drainage ditches. If hazardous materials are spilling from your vehicle:

- Park it and secure the area.
- Stay there.
- Call 9-1-1 or send someone else for help.

If you must send someone for help, give that person the following information in writing:

- A description of the emergency.
- Your exact location and direction of travel.
- Your name, the carrier's name, and the name of the community or city where your terminal is located.
- The shipping name, hazard class, and ID number of the material.

This information will help emergency crews to respond with the right equipment the first time.

## Other Hazards

**Explosives.** If your vehicle breaks down or is in an accident while carrying explosives, you must warn others of the danger. Keep bystanders away. Do not allow smoking or open fire near the vehicle.

Do not try to pull apart vehicles involved in an accident until any explosive cargo is removed. The explosives should be placed at least 200 feet from the vehicles and occupied buildings. If there is a fire, warn everyone of the danger of explosion and leave the area.

**Compressed Gases.** If compressed gas is leaking from your vehicle, warn others of the danger. Only permit those involved in removing the hazard or wreckage to get close. You must notify the shipper of the compressed gas of any accident or spill.

Do not transfer flammable compressed gas from one tank to another on any public roadway except in an emergency.

**Flammable liquids.** If you are transporting a flammable liquid and have an accident or your vehicle breaks down, prevent bystanders from gathering. Warn people of the danger. Keep them from smoking.

Never transport a leaking cargo tank farther than needed to reach a safe place. If safe to do so, get off the roadway. Do not transfer flammable liquid from one vehicle to another on a public roadway except in an emergency.

**Flammable solids and oxidizing materials.** If a flammable solid or oxidizing material spills, warn others of the fire hazard. Do not open smoldering packages of flammable solids. Remove them from the vehicle if you can safely do so. Also remove unbroken packages if it will decrease the fire hazard.

**Corrosive materials.** If corrosives spill or leak in transit, be careful to avoid further damage or injury when handling the containers. Parts of the vehicle exposed to a corrosive liquid must be thoroughly neutralized. Clean the interior as soon after unloading as possible, before reloading the vehicle.

If further transportation of a leaking tank would be unsafe, get off the road. If safe to do so, try to contain any liquid leaking from the vehicle. Keep bystanders away from the liquid and its fumes. Do everything possible to prevent injury to other highway users.

**Poisons.** You must protect yourself, other people, and property from harm. Remember that many

products classed as poison are also flammable. Warn bystanders of the hazards of fire, of inhaling vapors, or coming in contact with the poison. Do not allow smoking or open flame.

A vehicle involved in a leak of Division 2.3 or Division 6.1 poisons must be checked for stray poison before being used again.

If you know that a leaking poison liquid or gas is flammable, take the added precautions needed for flammable liquids or gases.

**Radioactive materials.** If a leak or broken package involves radioactive materials, notify your dispatcher or supervisor as soon as possible. If there is a spill, or if an internal container might be damaged, do not touch or inhale the material. Do not use the vehicle until it is decontaminated and checked with a survey meter.

The National Response Center helps coordinate emergency response to chemical hazards. They are a resource to the local police and fire fighters. Their 24-hour toll free number is 1-800-424-8802 or within California, 1-800-852-7550. The person in charge of a vehicle involved in an accident may have to phone the National Response Center. The call will be in addition to any made to police or fire fighters. You or your employer must phone when any of the following occurs as a direct result of hazardous materials incident:

- There is spill or release of a reportable quantity (RQ) hazardous substance.
- A person is killed.
- A person receives injuries requiring hospitalization.
- Estimated carrier or other property damage exceeds \$50,000.
- The general public is evacuated for one or more hours.
- One or more major transportation arteries or facilities are closed or shut down for one hour or more.

- Fire, breakage, spillage, or suspected radioactive contamination occurs and/or involves a shipment of etiologic agents (bacteria or toxins).
- A situation exists of such a nature (i.e., continuing danger to life exists at the scene of an incident) that, in the judgment of the carrier, should be reported.

The person making the immediate telephone report should be ready to give:

- His or her name.
- Name and address of the carrier.
- Phone number where someone can be reached.
- Date, time, and location of incident.
- The extent of injuries, if any.
- Classification, name, and quantity of hazardous materials involved, if such information is available.
- Type of incident and nature of hazardous substance involvement and whether a continuing danger to life exists at the scene.
- If a reportable quantity of hazardous substance was involved, the caller should give the following:

- the name of the shipper.
- the quantity of the hazardous substance discharged.

You should know these immediate reporting requirements so you can give your employer the required information. Carriers must also make detailed written reports within 30 days.

The Chemical Transportation Emergency Center (CHEMTREC) in Washington D.C. also has a 24 hour toll free line (1-800-424-9300). CHEMTREC was established to provide emergency personnel with technical information about the physical properties of hazardous products. The National Response Center and CHEMTREC are in close communication. If you call either one, they will tell the other about the problem, when appropriate.

### **California Immediate Spill Reporting**

Spills of hazardous materials on California highways must be reported immediately to the CHP office or police department having traffic control jurisdiction. (VC §23112.5)



























HAZARD CLASS and DIVISION	DEFINITION
<b>CLASS 1—EXPLOSIVES</b>	
Division 1.1	Explosives that have a mass explosion hazard (affects almost the entire load instantaneously). (Refer to 49 CFR 173.50(b)[1].)
Division 1.2	Explosives that have a projection hazard but not a mass explosion hazard. (Refer to 49 CFR 173.50 (b)[2].)
Division 1.3	Explosives that have a fire hazard and either a minor blast or projection hazard or both, but not a mass explosion hazard. (Refer to 49 CFR 173.50 (b)[3].)
Division 1.4	Explosives that present a minor explosion hazard (effects are largely confined to the package). (Refer to 49 CFR 173.50 (b)[4].)
Division 1.5	Explosives that are very insensitive (very little probability of detonation under normal transport condition). (Refer to 49 CFR 173.50 (b)[5].)
Division 1.6	Articles which do not have a mass explosive hazard (negligible probability of accidental detonation). (Refer to 49 CFR 173.50 (b)[6].)
<b>CLASS 2—GASES</b>	
Division 2.1	Flammable gas is any material which is a gas at 20°C (68°F) or less and 101.3 kPa (14.7 psi) of pressure and is ignitable when mixed with air. (Refer to 49 CFR 173.115[a].)
Division 2.2	Division 2.2 includes non-flammable, non-poisonous compressed gas including compressed gas, liquefied gas, pressurized cryogenic gas and compressed gas in solution, asphyxiant gas, or oxidizing gas with an absolute pressure of 280 kpa (40.6 PSIA) or greater at 20°C (68°F). (Refer to 49 CFR 173.115[b].)
Division 2.3	A gas poisonous by inhalation is a gas which is known to be so toxic to humans as to pose a hazard to health during transportation. (Refer to 49 CFR 173.115[c].)
<b>CLASS 3—FLAMMABLE LIQUIDS</b>	
<p>A flammable liquid means a liquid having a flash point of not more than 60.5°C (141°F), or any material in a liquid phase with a flash point at or above 37.8°C (100°F) that is intentionally heated and offered for transport, or transported at or above its flash point in a bulk package, with the following exceptions:</p> <ul style="list-style-type: none"> <li>• Any liquid meeting one of the definitions specified in 49 CFR 173.115 (gases).</li> <li>• Any mixture having one or more components with a flash point of 60.5°C (141°F) or higher, that makes up at least 99% of the total volume of the mixture, if the mixture is not offered for transportation or transported at or above its flash point.</li> </ul>	
<b>CLASS 4—FLAMMABLE SOLIDS</b>	
Division 4.1	<p>A flammable solid means any of the following three types of material:</p> <ol style="list-style-type: none"> <li>1. Desensitized Explosives that: A) when dry are explosives Class 1 other than those of compatibility group A, which are wetted with sufficient water, alcohol, or plasticizer to suppress explosive properties; and B) are specifically authorized by name and hazard class by the Associate Administrator for Hazardous Materials under the provisions of an exemption issued under subchapter A of 49 CFR or an approval issued under 49 CFR 173.56(i).</li> <li>2. Self-reactive materials are materials that are liable to undergo, at normal or elevated temperature, a strong exothermal decomposition caused by excessively high transport temperatures or by contamination, even without participation of oxygen (air).</li> </ol>

<b>CLASS 4—FLAMMABLE SOLIDS, continued</b>	
Division 4.1, continued	3. Readily combustible materials are materials that are solids which may cause fire through friction such as matches; shows a burn rate of more than 2.2 mm (0.087 inches); or any metal powders that can be ignited and react over the whole length of the sample in 10 minutes or less.
Division 4.2	A spontaneously combustible material means:  1. A Pyrophoric Material—a liquid or solid that, even in small quantities, and without an external ignition source, can ignite within five minutes after coming in contact with air.  2. A Self-heating Material—a material that, when in contact with air and without an energy supply is liable to self heat. A material of this type which exhibits spontaneous ignition or if the temperature of a sample exceeds 200°C (392°F) in 24 hours is a Division 4.2 material.
Division 4.3	A dangerous when wet material is a material that, by contact with water, is liable to become spontaneously flammable or to give off flammable or toxic gas. (Refer to 49 CFR 173.124 [c].)
<b>CLASS 5—OXIDIZING MATERIALS</b>	
Division 5.1	An oxidizer is any material that may, generally by yielding oxygen, cause or enhance the combustion of other materials. (Refer to 49 CFR 173.127 [a].)
Division 5.2	Organic peroxide is a compound containing oxygen (O) in the bivalent -O-O structure and which may be considered a derivative of hydrogen peroxide where one or more of the hydrogen atoms have been replaced by organic radicals. (Refer to 49 CFR 173.128 [a].)
<b>CLASS 6—POISONOUS/INFECTIOUS SUBSTANCES</b>	
Division 6.1	A poisonous material is any material, other than a gas, which is known to be so toxic to humans that it causes a hazard to health during transportation. (Refer to 49 CFR 173.132 [a].)
Division 6.2	An infectious substance is a viable microorganism, or its toxin, which causes or may cause disease in humans or animals. (Refer to 49 CFR 173.134 [a].)
<b>CLASS 7—RADIOACTIVE MATERIALS</b> (Refer to 49 CFR 173.403.)	
<b>CLASS 8—CORROSIVE MATERIALS</b>	
A corrosive material is any liquid or solid that causes visible destruction or irreversible alterations in human skin tissue at the site of contact, or a liquid that has a severe corrosion rate on steel or aluminum. (Refer to 49 CFR 173.136 [a].)	
<b>CLASS 9—MISCELLANEOUS HAZARDOUS MATERIALS</b>	
A miscellaneous hazardous material is any material which presents a hazard during transportation but which does not meet the definition of any other hazard class. (Refer to 49 CFR 173.140.)	
<b>ORM-D MATERIALS</b>	
Other Regulated Materials (ORM) means a material such as a consumer commodity, which, although otherwise subject to the regulations of 49 CFR 173, presents a limited hazard during transportation due to its form, quantity, and packaging. (Refer to 49 CFR 173.144.)	
<b>COMBUSTIBLE LIQUIDS</b>	
A combustible liquid is any liquid that does not meet the definition of any other hazard class and has a flash point above 141°F, but less than 220°F. (Refer to 49 CFR 173.120[a]).	
<b>NOTE:</b> Some flammable liquids with a flash point at or above 100°F may be reclassified as combustible liquid for domestic transportation (Refer to 49 CFR 173.120[b]).	

<p>CLASS 1 Explosive 1.1, 1.2, 1.3</p> <p>*Include appropriate division number and compatibility group letter.</p>	<p>CLASS 1 Explosive 1.4</p> <p>*Include appropriate compatibility group letter.</p>	<p>CLASS 1 Explosive 1.5</p> <p>*Include appropriate compatibility group letter.</p>	<p>CLASS 1 Explosive 1.6</p> <p>*Include appropriate compatibility group letter.</p>	<p>CLASS 2 Division 2.1</p> <p>Flammable gas</p>	<p>CLASS 2 Division 2.2</p> <p>Non-flammable gas</p>	<p>CLASS 2 Division 2.2</p> <p>Oxygen</p>
<p>CLASS 2 Division 2.3</p> <p>Poison gas</p>	<p>CLASS 3</p> <p>Flammable liquid</p>	<p>CLASS 4 Division 4.1</p> <p>Flammable solid</p>	<p>CLASS 4 Division 4.2</p> <p>Spontaneously Combustible</p>	<p>CLASS 4 Division 4.3</p> <p>Dangerous when wet</p>	<p>CLASS 5 Division 5.1</p> <p>Oxidizer</p>	<p>CLASS 5 Division 5.2</p> <p>Organic peroxide</p>
<p>CLASS 6 Division 6.1</p> <p>Poison-Inhalation Hazard only, Zone A or B.</p>	<p>CLASS 6 Division 6.1</p> <p>POISON Placard 454 kg (1,001 lbs) or more of PG I or II, other than Zone A or B, inhalation hazard.</p>	<p>CLASS 6 Division 6.1</p> <p>Poison-PG III</p>	<p>CLASS 6 Division 6.2</p> <p>INFECTIONIOUS SUBSTANCE</p> <p>29 CFR 1910.1030 BIOHAZARD marking may be used for Regulated Medical Waste (RMW).</p>	<p>CLASS 7</p> <p>Radioactive WHITE-I</p>	<p>CLASS 7</p> <p>Radioactive YELLOW-II</p>	
<p>CLASS 7</p> <p>Radioactive YELLOW-III</p>	<p>CLASS 8</p> <p>Corrosive</p>	<p>CLASS 9</p> <p>Miscellaneous</p>	<p>SUBSIDIARY RISK LABELS</p> <p>Explosive Flammable gas Flammable liquid Flammable solid Corrosive Oxidizer Poison Spontaneously Combustible Dangerous when wet</p> <p>The class number may not be displayed on a subsidiary label (see Section 172.402).</p>		<p>EMPTY</p> <p>Empty-Radioactive</p>	<p>FOR AIRCRAFT</p> <p>MAGNETIZED MATERIAL</p> <p>Cargo Aircraft Only</p> <p>DANGER</p>
<p>TRANSITION-2001</p> <p>EXPLOSIVE A</p>	<p>TRANSITION-2001</p> <p>EXPLOSIVE B</p>	<p>TRANSITION-2001</p> <p>EXPLOSIVE C</p>	<p>TRANSITION-2001</p> <p>BLASTING AGENT</p>	<p>TRANSITION-2001</p> <p>FLAMMABLE SOLID</p>	<p>TRANSITION-2001</p> <p>IRRITANT</p>	

HAZARDOUS MATERIALS MARKINGS

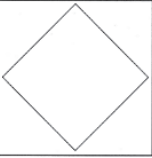
<p>INNER PACKAGES COMPLY WITH PRESCRIBED SPECIFICATIONS</p> <p>§173.25(a)(4)</p> <p>§172.312(a)</p>	<p>MARINE POLLUTANT</p> <p>§172.322</p> <p>§172.325</p>	<p>DANGER</p> <p>THIS UNIT IS UNDER FUMIGATION WITH _____ APPLIED ON _____</p> <p>Date: _____</p> <p>Thru: _____</p> <p>DO NOT ENTER</p> <p>§172.302(g) and §173.9</p>	<p>INHALATION HAZARD</p> <p>§172.313(a)</p>	<p>CONSUMER COMMODITY</p> <p>ORM-D</p> <p>§172.316(a)</p>	<p>CONSUMER COMMODITY</p> <p>ORM-D-AIR</p> <p>§172.316(a)(1)</p>
---	---	--	---	---	--

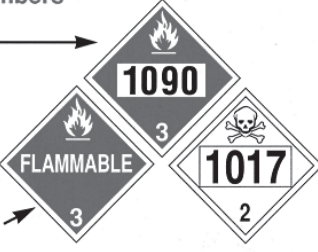
<p>CLASS 1</p>  <p><b>EXPLOSIVES</b> * Enter Division Number 1.1, 1.2, or 1.3 and compatibility group letter, when required. Placard any quantity.</p>	<p>CLASS 1</p>  <p><b>1.4 EXPLOSIVES</b> * Enter compatibility group letter, when required. Placard 454 kg (1,001 lbs) or more.</p>	<p>CLASS 1</p>  <p><b>1.5 BLASTING AGENTS</b> * Enter compatibility group letter, when required. Placard 454 kg (1,001 lbs) or more.</p>	<p>CLASS 1</p>  <p><b>1.6 EXPLOSIVES</b> * Enter compatibility group letter, when required. Placard 454 kg (1,001 lbs) or more.</p>	<p>CLASS 2</p>  <p><b>OXYGEN</b> Placard 454 kg (1,001 lbs) or more gross weight of either compressed gas or refrigerated liquid.</p>
<p>CLASS 2</p>  <p><b>FLAMMABLE GAS</b> Placard 454 kg (1,001 lbs) or more.</p>	<p>CLASS 2</p>  <p><b>NON-FLAMMABLE GAS</b> Placard 454 kg (1,001 lbs) or more gross weight.</p>	<p>CLASS 2</p> <p style="text-align: right;">Division 2.3</p>  <p><b>INHALATION HAZARD</b> Placard any quantity.</p>	<p>CLASS 3</p>  <p><b>FLAMMABLE</b> Placard 454 kg (1,001 lbs) or more.</p>	<p>CLASS 3</p>  <p><b>GASOLINE</b> May be used in the place of FLAMMABLE placard displayed on a cargo tank or a portable tank being used to transport gasoline by highway.</p>
<p>CLASS 3</p>  <p><b>COMBUSTIBLE</b> Placard a combustible liquid when transported in bulk. See §172.504(f)(2) for use of FLAMMABLE placard in place of COMBUSTIBLE placard.</p>	<p>CLASS 3</p>  <p><b>FUEL OIL</b> May be used in place of COMBUSTIBLE on a placard displayed on a cargo tank or portable tank being used to transport by highway fuel oil not classed as a flammable liquid.</p>	<p>CLASS 4</p>  <p><b>FLAMMABLE SOLID</b> Placard 454 kg (1,001 lbs) or more.</p>	<p>CLASS 4</p>  <p><b>SPONTANEOUSLY COMBUSTIBLE</b> Placard 454 kg (1,001 lbs) or more.</p>	<p>CLASS 4</p>  <p><b>DANGEROUS WHEN WET</b> Placard any quantity of Division 4.3 material.</p>
<p>CLASS 5</p>  <p><b>OXIDIZER</b> Placard 454 kg (1,001 lbs) or more.</p>	<p>CLASS 5</p>  <p><b>ORGANIC PEROXIDE</b> Placard any quantity, TYPE B, temperature controlled. Placard 454 kg (1,001 lbs) or more other than TYPE B, temperature controlled.</p>	<p>CLASS 6</p>  <p><b>INHALATION HAZARD</b> Placard any quantity of 6.1, Zone A or B inhalation hazard only.</p>	<p>CLASS 6</p>  <p><b>POISON</b> Placard 454 kg (1,001 lbs) or more of PGI or II, other than Zone A or B inhalation hazard.</p>	<p>CLASS 7</p>  <p><b>RADIOACTIVE</b> Placard any quantity - packages bearing RADIOACTIVE YELLOW-III labels only. Certain low specific activity radioactive materials in "exclusive use" will not bear the label, but the Radioactive placard is required for exclusive use shipments of low specific activity material and surface contaminated objects transported in accordance with §173.427 (b)(3) or (c).</p>
<p>CLASS 8</p>  <p><b>CORROSIVE</b> Placard 454 kg (1,001 lbs) or more.</p>	<p>CLASS 9</p>  <p><b>MISCELLANEOUS</b> Not required for domestic transportation. A bulk packaging containing a Class 9 material must be marked with the appropriate ID number displayed on a Class 9 placard, an orange panel or a white square-on-point display.</p>	<p>CLASS 9</p>  <p><b>DANGEROUS</b> A freight container, unit load device, transport vehicle, or rail car which contains non-bulk packagings with two or more categories of hazardous materials that require different placards specified in Table 2 may be placarded with DANGEROUS placards instead of the specific placards required for each of the materials in Table 2. However, when 1,000 kg (2,205 lbs) or more of one category of material is loaded at one loading facility, the placard specified in Table 2 must be applied.</p>	<p>CLASS 9</p>  <p><b>SUBSIDIARY RISK PLACARD</b> Class numbers do not appear on a subsidiary risk placard.</p>	
 <p>White square background required for placard for highway route controlled quantity radioactive material and for rail shipment of certain explosives and poisons, and for flammable gas in a DOT 113 tank car (see §§172.507 and 172.510).</p>	<p><b>UN or NA Identification Numbers</b></p> <p>PLACARDS OR ORANGE PANELS</p>  <p>and</p>  <p>Appropriate Placard must be used.</p>			<p><b>MUST BE DISPLAYED ON:</b> (1) Tank Cars, Cargo Tanks, Portable Tanks, other Bulk Packaging, and (2) On vehicle or containers containing large quantities (8,820 lbs.) In non-bulk packages of only a single hazardous material, and certain quantities (2,205) of a material poisonous by inhalation in Hazard Zone A or B, having the same proper shipping name and Identification number.</p>

**LABELS**

See 49 CFR, Part 172, Subpart E for complete labeling regulations.

- Until October 1, 1999, labels for materials poisonous by inhalation that conform to the requirements of the HMR in effect on September 30, 1997, may be used to satisfy the requirements of Subpart E.
- Those labels in boxes marked "TRANSITION-2001" on the chart are not authorized for use under Subpart E. (NOTE: these labels may be used IF they were affixed to a package offered for transportation and transported prior to October 1, 2001, and the package was filled with hazardous materials prior to October 1, 1991.)
- For classes 1,2,3,4,5,6 and 8, text indicating a hazard (e.g., "CORROSIVE") IS NOT required on a label. The label must otherwise conform to Subpart E [Section 172.405].
- Any person who offers a hazardous material for transportation MUST label the package, if required [Section 172.400(a)].
- The Hazardous Materials Table [Section 172.101] identifies the proper label(s) for the hazardous material listed.
- When required, labels must be printed on or affixed to the surface of the package near the proper shipping name [Section 172.406(a)].
- When two or more labels are required, they must be displayed next to each other [Section 172.406(c)].
- Labels may be affixed to packages when not required by regulations, provided each label represents a hazard of the material contained in the package [Section 172.401].

**PLACARDS**

See 49 CFR, Part 172, Subpart F for complete placarding regulations.

- Until October 1, 2001, placards for materials poisonous by inhalation, by all modes of transportation, may be used that conform to specifications for placards (1) in effect on September 30, 1991, (2) specified in the December 21, 1990 final rule, (HM-181) or (3) specified in the July 22, 1997 final rule (HM-206).
- All of the placards appearing on the Hazardous Materials Warning Placards chart may be used to satisfy the placarding requirements contained in Subpart F.
- Each person who offers for transportation or transports any hazardous material subject to the Hazardous Materials Regulations shall comply with all applicable requirements of Subpart F.
- Placards may be displayed for a hazardous material even when not required, if the placarding otherwise conforms to the requirements of Subpart F.
- For other than Class 7 or the OXYGEN placard, text indicating a hazard (e.g., "CORROSIVE") is not required on a placard [Section 172.519(b)].
- Any transport vehicle, freight container, or rail car containing any quantity of material listed in Table 1 must be placarded [Section 172.504].
- When the gross weight of all hazardous materials in non-bulk pkgs. covered in Table 2 is less than 454 kg (1,001 lbs), no placard is required on a transport vehicle or freight container [Section 172.504].

Effective October 1, 1994, and extending through October 1, 2001, these placards may be used for HIGHWAY TRANSPORTATION ONLY.



Illustration numbers in each square refer to Tables 1 and 2 below.

**Inhalation Hazard Materials**



Materials which meet the inhalation toxicity criteria have additional "communication standards" prescribed by the HMR. First, the words "Poison-Inhalation Hazard" must be entered on the shipping paper, as required by Section 172.203(m)(3). Second, packaging must be marked "Inhalation Hazard" or, alternatively, when the words "Inhalation Hazard" appear on the label or placard, the "Inhalation Hazard" marking is not required on the package. Transport vehicles, freight containers, portable tanks and unit load devices that contain a poisonous material subject to the "Poison-Inhalation Hazard" shipping description, must be placarded with a POISON INHALATION HAZARD or POISON GAS placard, as appropriate. This shall be in addition to any other placard required for that material in Section 172.504.

**Table 1 (Placard any quantity)**

Hazard class or division	Placard name
1.1	EXPLOSIVES 1.1
1.2	EXPLOSIVES 1.2
1.3	EXPLOSIVES 1.3
2.3	POISON GAS
4.3	DANGEROUS WHEN WET
5.2 (Organic peroxide, Type B, liquid or solid, temperature controlled)	ORGANIC PEROXIDE
6.1 (Inhalation Hazard, Zone A or B)	POISON INHALATION HAZARD
7 (Radioactive Yellow III label only)	RADIOACTIVE

**Table 2 (Placard 1,001 pounds or more)**

1.4	EXPLOSIVES 1.4
1.5	EXPLOSIVES 1.5
1.6	EXPLOSIVES 1.6
2.1	FLAMMABLE GAS
2.2	NON-FLAMMABLE GAS
3	FLAMMABLE
Combustible Liquid	COMBUSTIBLE
4.1	FLAMMABLE SOLID
4.2	SPONTANEOUSLY COMBUSTIBLE
5.1	OXIDIZER
5.2 (Other than organic peroxide, Type B, liquid or solid, temperature controlled)	ORGANIC PEROXIDE
6.1 (PG I or II, other than Zone A or B inhalation hazard)	POISON
6.1 (PG III)	KEEP AWAY FROM FOOD
6.2	NONE
8	CORROSIVE
9	CLASS 9
ORM-D	NONE

For complete details, refer to one or more of the following:

- Code of Federal Regulations, Title 49, Transportation, Parts 100-185. [All modes]
- International Civil Aviation Organization (ICAO) Technical Instructions for Safe Transport of Dangerous Goods by Air [Air]
- International Maritime Organization (IMO) Dangerous Goods Code [Water]
- Transportation of Dangerous Goods Regulations of Transport Canada. [All Modes]



U.S. Department of Transportation  
**Research and Special Programs Administration**

Copies of this Chart can be obtained by writing

**OHMIT/DHM-51,**  
 Washington, D.C. 20590

or

Phone: 202-366-4900

E-mail: [training@rspa.dot.gov](mailto:training@rspa.dot.gov)

Web site: <http://hazmat.dot.gov>



## Section 10: Pre-Trip Test

This section will assist drivers taking the pre-trip test

A pre-trip inspection should be done the same way each time so you will learn all the steps and be less likely to forget something during the test.

Before your pre-trip test, the examiner will check the brake lights, emergency flashers, turn signals, and horn. If any of these items do not work, the skills and driving portions of the test will be postponed.

Pre-trips are conducted to ensure that a vehicle is safe to operate. During the pre-trip test, you will be expected to explain or show your knowledge of the pre-trip process.

You must point to every item you would check, identify it, and explain in detail what you are checking the item for. You will NOT have to crawl under the vehicle. The only portion of the test that requires a demonstration for scoring purposes is the Air Brakes Test portion, if the vehicle you are testing in is equipped with air brakes.

You may use the guides shown on pages 125 or 126 when taking your pre-trip test. You cannot write any instructions or notes on how to perform the pre-trip inspection on the guide. If you do not pass the pre-trip inspection test, the other tests will be postponed.

**Remember:** You are allowed a total of three attempts to pass the pre-trip, skills, or driving tests. See page 6.

### All Vehicles

Study the following vehicle parts for the type of vehicle you will be using during the CDL skills tests. You should be able to identify each part and tell the examiner what you are looking for or inspecting.

### Vehicle Overview

As you approach the vehicle, notice its general condition. Look for damage or if the vehicle is leaning to one side. Look under the vehicle for fresh oil, coolant, grease, or fuel leaks. Check area around the vehicle for hazards to vehicle movement such as people, other vehicles, objects, low hanging wires, or limbs, etc.

Check the parking brakes are set and/or wheels chocked. You may have to raise the hood, tilt the cab (secure loose objects so they don't fall and break something), or open the engine compartment door. Check the following:

### Engine Compartment (Engine Off)

**Leaks/Hoses** (fuel, coolant, oil, power steering fluid, hydraulic fluid, battery fluid, etc.)

- Look for puddles on the ground.
- Look for dripping fluids on underside of engine and transmission.
- Inspect hoses for condition and leaks.

### Oil Level

- Indicate where dipstick is located
- See that oil level is within safe operating range. Level must be above refill mark.

### Coolant Level

- Inspect reservoir sight glass or
- (If engine is not hot), remove radiator cap and check for visible coolant level.

### Power Steering Fluid

- Indicate where power steering fluid dipstick is located.
- Check for adequate power steering fluid level. Level must be above refill mark.

### Windshield Washer Fluid Level

- Check fluid level and cap secure

**Automatic transmission fluid level** (may require engine to be running)

### Engine Compartment Belts

- Check and identify the following belts for snugness, cracks, frays, or excessive wear:
  - power steering belt
  - water pump belt
  - alternator belt
  - air compressor belt

### Cab Check/Engine Start

Get in and start the engine.

**NOTE:** Ensure engine compartment hood is closed and latched. Cab-over-primary and safety locks engaged.

### Clutch/Gearshift

- Make sure the parking brake is set.
- Depress clutch.
- Place gearshift lever in neutral (or park, for automatic transmissions).
- Start engine, then release clutch slowly.
- Accelerator checked for looseness, sticking, or damage.
- Listen for unusual engine noises.

### Oil Pressure Gauge

- Make sure oil pressure gauge is working.
- Check that pressure gauge shows increasing or normal oil pressure or that the warning light goes off.
- If equipped, oil temperature gauge should begin a gradual rise to the normal operating range.

### Coolant Temperature Gauge

- Make sure the temperature gauge is working.
- Temperature should begin to climb to the normal operating range or temperature light should be off.

### Ammeter/Voltmeter

- Check that gauges show alternator and/or generator is charging or that warning light is off.

### Oil Temperature Gauge

- Check that gauge begins gradual rise to normal operating range.

### Mirrors and Windshield

- Mirrors should be clean and adjusted properly from the inside.
- Windshield should be clean with no illegal stickers, no obstructions, or damage to the glass.

### Emergency Equipment

- Check for spare electrical fuses.
- Check for three red reflective triangles.
- Check for a properly charged and rated fire extinguisher.

### Check Optional Emergency Equipment

- Tire chains (where winter conditions require them)
- Tire changing equipment
- List of emergency phone numbers
- Accident reporting kit (packet)

### Steering Wheel

- Check for looseness, sticking, or damage.

### Steering Play

- **Non-power steering:** Check for excessive play by turning steering wheel back and forth. Play should not exceed 10% (about two inches on a 20-inch wheel).
- **Power steering:** With the engine running, check for excessive play by turning the steering wheel back and forth. Play should not exceed 10% (about two inches on a 20-inch wheel) before front left wheel barely moves.

### Wipers/Washers

- Check that wiper arms and blades are secure, not damaged, and operate smoothly.

### Lighting Indicators

- Test that dash indicators work when corresponding lights are turned on:
  - left and right turn signals
  - 4-way emergency flashers
  - high beam headlight

### Horn

- Check that air horn and/or electric horn work.

### Heater/Defroster

- Test that the heater and defroster work.

### Parking Brake Check

- Fasten your seat belt.
- Allow the vehicle to move forward slowly and apply the parking brake or set the brake and try to move the vehicle. The brake should not allow any movement.

### Hydraulic Brake Check

- Pump the brake pedal three times, then hold it down for five seconds. The brake pedal should not move during the five seconds.
- If equipped with a hydraulic brake reserve system, with the key off, depress the brake pedal and listen for the sound of the reserve system electric motor.
- If equipped with a “Hydro—Boost” brake system, release the parking brake and with the engine off, depress and release the brake pedal several times to deplete all hydraulic pressure. Depress and hold the brake pedal with light pressure (15–25 lbs) then start the engine and run it at idle speed. If the Hydro—Boost is operating, the pedal will yield slightly to foot pressure and then hold. Less pressure is required to hold the pedal at this position.
- Check that the warning buzzer or light is off.

### Air Brake Check (for air brake equipped vehicles only)

Refer to Section 5, “In-Cab Air Brake Check” on page 70 for DMV pre-trip testing. All

items marked with an asterisk (\*) are required during the pre-trip test. These items must be demonstrated and the parameters verbalized to receive credit. Failure to perform these air brakes tests correctly will result in an automatic disqualification for the entire pre-trip portion of the test.

### Seat Belts

- Check that the seat belt is securely mounted, adjusts, and latches properly.

## External Inspection (Buses, Trucks, Tractors)

### Lights/Reflectors

- Check that all external lights and reflective equipment are clean and functional. Light and reflector checks include:
  - clearance lights (red on rear, amber elsewhere)
  - headlights (high and low beams)
  - taillights
  - turn signals (left and right)
  - 4-way flashers
  - brake lights
  - red reflectors (on rear) and amber reflectors (elsewhere)
  - license plate light(s)
- **Note:** Checks of brake, turn signal, and 4-way flasher functions must be done separately.

### Steering

#### Steering Box/Hoses

- Check that the steering box is securely mounted and not leaking. Look for any missing nuts, bolts, and cotter keys.
- Check for power steering fluid leaks or damage to power steering hoses.

#### Steering Linkage

- See that connecting links, arms, and rods from the steering box to the wheel are not worn or cracked.

- Check that joints and sockets are not worn or loose and that there are no missing nuts, bolts, or cotter keys.

## Suspension

### Springs/Air/Torque

- Look for missing, shifted, cracked, or broken leaf springs (if 1/4 or more are missing or broken, it will put the vehicle out of service).
- Look for broken or distorted coil springs.
- If vehicle is equipped with torsion bars, torque arms, or other types of suspension components, check that they are not damaged and are mounted securely.
- Air ride suspension should be checked for damage and leaks.
- Axles secure
- If retractable axle equipped, check condition of lift mechanism. If air powered, check for leaks.

### Mounts

- Look for cracked or broken spring hangers, missing or damaged bushings, and broken, loose, or missing bolts, U-bolts, or other axle mounting parts.

### Shock Absorbers

- See that shock absorbers are secure and that there are no leaks.

**NOTE:** Be prepared to perform the same suspension components inspection on every axle (power unit and trailer, if equipped).

## Brakes

### Slack Adjustors

- Look for broken, loose, or missing parts.
- When the brakes are applied, the push rod from the brake chamber should not move more than two inches. (It is also acceptable to state that the angle between the push rod and the adjustor arm should be a little over 90° when the brakes are released, and not less than 90° when the brakes are applied.)

### Brake Chambers

- See that brake chambers are not leaking, cracked, dented, and are mounted securely.

### Brake Hoses/Lines

- Look for cracked, worn, or leaking hoses, lines, and couplings.

### Brake Drums

- Check for cracks, dents, or holes. Also check for loose or missing bolts.

### Brake Linings

- Brake linings, where visible, should not be worn down dangerously thin.

**NOTE:** Be prepared to perform the same brake components inspection on every axle (power unit and trailer, if equipped.)

## Wheels

### Rims, Rim Locks, or Slide Ring

- Check for damaged, cracked (except an intentionally manufactured crack at a valve stem hole), or bent rims and for any bent, broken, improperly seated, sprung, or mismatched rings. Rims cannot have welding repairs.

### Tires

- The following items must be inspected on every tire:
  - tread depth: Check for minimum tread depth (4/32 inch on steering axle tires, 2/32 inch on all other tires).
  - tire condition: Check that tread is evenly worn and look for cuts or other damage to tread or sidewalls. Also, make sure that valve caps and stems are not missing, broken, or damaged.
  - tire inflation: Check for proper inflation by using a tire gauge, or inflation by striking tires with a mallet or other similar device.

- tires same size. Duals not touching and nothing stuck between them.
- tires same type (not mixed radial and bias). Front tires for buses cannot be recapped, retreaded, or regrooved.

**NOTE:** You will not get credit if you simply kick the tires to check for proper inflation.

### Hub Oil Seals/Axle Seals

- See that hub oil/grease seals and axle seals are not leaking and, if wheel has a sight glass, oil level is adequate.

### Wheel Fasteners

- Check that all wheel fasteners are present, free of cracks and distortions, and show no signs of looseness such as rust trails or shiny threads.
- Make sure all bolt holes are not cracked or distorted.

### Spacers

- If equipped, check that spacers are not bent, damaged, or rusted through.
- Spacers should be evenly centered, with the dual wheels and tires evenly separated.
- No debris between dual tires.

**Note:** Be prepared to perform the same wheel inspection on every axle (power unit and trailer, if equipped).

### Side of Vehicle

#### Door(s)/Mirror(s)/Window(s)

- Check that door(s) are not damaged and that they open and close properly.
- Hinges should be secure with seals intact.
- Check that mirror(s) are clean, mirror brackets are not damaged, and mirrors are mounted securely with no loose attachments.
- Windows are clean and work properly.

### Fuel Tank

- Check that tank(s) are secure, cap(s) are tight, and that there are no leaks from tank(s) or lines.

### Battery/Box

- Wherever located, if visible, checks that battery(ies) are secure, connections are tight, and cell caps are present (unless maintenance free).
- Battery connections, if visible, should not show signs of excessive corrosion.
- Battery box and cover or door must be secure.
- Fluid level, if visible, is adequate (unless maintenance free).
- Cell caps are present and securely tightened (unless maintenance free).
- Vents in caps are free of foreign matter (unless maintenance free).

### Drive Shaft

- See that drive shaft is not bent or cracked.
- Couplings should be secure and free of foreign objects.

### Exhaust System

- Check system for damage and signs of leaks such as rust or carbon soot.
- System should be connected tightly and mounted securely.
- Exhaust system should not have excessive noise when engine is running.

### Frame

- Look for cracks, bends, aftermarket welds, or holes to longitudinal frame members and cross members.

### Condition of Visible Parts

- Rear of engine not leaking
- Transmission not leaking
- Air lines and electrical wiring secured against sagging, rubbing, or wearing.

- Spare tire carrier or rack not damaged (if so equipped).
- Spare tire and/or wheel securely mounted in rack (if so equipped).
- Spare tire and wheel adequate (proper size, properly inflated, and in good condition).

## Rear of Vehicle

### Splash Guards

- If equipped, check that splash guards or mud flaps are not damaged and are mounted securely, not dragging on ground, or rubbing tires.

### Doors/Ties/Lifts

- Check that doors and hinges are not damaged and that they open, close, and latch properly from the *outside*, if equipped.
- Ties, straps, chains, and binders must also be secure.
- If equipped with a cargo lift, look for leaking, damaged or missing parts, and explain how it should be checked for correct operation.
- Lift must be fully retracted and latched securely.

## Tractor/Coupling

### Air/Electric Lines

- Listen for air leaks. Check that air hoses and electrical lines are not cut, chafed, spliced, or worn (steel braid should not show through).
- Make sure air and electrical lines are not tangled, pinched, or dragging against tractor parts.

### Catwalk/Tongue Storage Area

- Check that the catwalk is solid, clear of objects, and securely bolted to tractor frame.
- Check that the storage area is solid and secured to the tongue.
- Cargo in the storage area (i.e., chains, binders, etc.) must be secured.

## Mounting Bolts

- Check for loose or missing mounting brackets, clamps, bolts, or nuts. Both the fifth-wheel and the slide mounting must be solidly attached.
- On other types of coupling systems (i.e., ball hitch, pintle hook, etc.), inspect all coupling components and mounting brackets for missing or broken parts.
- Check for loose or missing mounting bolts. Look for broken welds on the pintle hook, or other hitch mount, and tongue/drawbar assembly to be sure they are solidly attached in place.

## Safety Latch/Locking Jaws/Safety Devices

- Look into fifth-wheel gap and check that locking jaws are fully closed around the kingpin.
- Check that the latch is secured and locked in place and that the cotter pin is not missing, is in place, and not damaged.
- Safety chains must be hooked and crisscrossed, free of kinks and excessive slack, cotter pins to hooks are in place and hooks are secured with the hooks pointing in an outward position.
- If trailer is equipped with electric brakes, check that the breakaway chains or cables with battery back up are not missing or damaged.
- On other types of coupling systems (i.e., ball hitch, drawbar/eye, etc.), inspect the locking mechanism for missing or broken parts and make sure it is locked securely. If present, safety cables or chains must be secure and free of kinks and excessive slack.

## Platform (fifth-wheel) (Pintle Hook)

- Check for cracks or breaks in the platform structure which supports the fifth-wheel skid plate.
- Check the pintle hook for cracks, breaks, or excessive wear.

### Release Arm (fifth-wheel)

- If equipped, make sure the release arm is in the engaged position and the safety latch is in place. Check to see if the hitch release lever is in place and secure.

### Kingpin/Apron/Gap/Tongue Drawbar

- Check that the kingpin is not bent.
- Make sure the visible part of the apron is not bent, cracked, or broken.
- Check that the trailer is laying flat on the fifth-wheel skid plate (no gap).
- Check that the tongue/drawbar is not bent or twisted. Check for broken welds and stress cracks.
- Check that the tongue/drawbar eye is not worn excessively.

### Sliding Fifth-Wheel Locking Pins/Sliding Pintle

- If equipped, look for loose or missing pins in the slide mechanism of the sliding fifth-wheel. If air powered, check for leaks.
- Make sure locking pins are fully engaged.
- Check that the fifth-wheel is positioned properly so the tractor frame will clear the landing gear during turns.
- If equipped, check that the sliding pintle is secured, that there are no loose or missing nuts or bolts, and that the cotter pin is in place.

## School Buses Only

### Emergency Equipment

- In addition to checking for spare electrical fuses, if equipped, three red reflective triangles, and a properly charged and rated fire extinguisher, school bus drivers must also inspect the following emergency equipment:
  - three red-burning flares (fusees) or three bidirectional emergency reflective triangles (FMVSS 125)

- a first aid kit consisting of 10–24 items, depending on the number of passengers

### Lighting Indicators

- In addition to checking the lighting indicators listed in Section 10.2 of this handbook, school bus drivers must also check the following lighting indicators (internal panel lights):
  - alternately flashing amber lights indicator, if equipped
  - alternately flashing red lights indicator
  - strobe light indicator, if equipped

### Lights/Reflectors

- In addition to checking the lights and reflective devices, school bus drivers must also check the following (external) lights and reflectors:
  - strobe light, if equipped
  - stop arm light, if equipped
  - alternately flashing amber lights, if equipped
  - alternately flashing red lights

### Stop Arm

- If equipped, check the stop arm to see that it is mounted securely to the frame of the vehicle. Also, check for loose fittings and damage.

### Passenger Entry/Lift

- Check that the entry door is not damaged, operates smoothly, and closes securely from the *inside*.
- Hand rails are secure and the step light is working, if equipped.
- The entry steps must be clear with the treads not loose or worn excessively.
- If equipped with a handicap lift, look for leaking, damaged, or missing parts and explain how lift should be checked for correct operation. Lift must be fully retracted and latched securely. Make sure the lift door warning device is activated when the door is open.

## Emergency Exit

- Make sure that all emergency exits are not damaged, operate smoothly, and close securely from the *inside*.
- Make sure that any exterior or interior locking devices, if equipped, are not “locked” and that the door is free to open.
- Check that any emergency exit warning devices are working.

## Seating

- Look for broken seat frames and check that seat frames are firmly attached to the floor.
- Check that seat cushions are attached securely to the seat frames.

## Trailer

### Front Of Trailer

#### Air/Electrical Connections

- Check that trailer air connectors are sealed and in good condition.
- Make sure glad hands are locked in place and free of damage or air leaks.
- Make sure the trailer electrical plug is firmly seated and locked in place.

#### Header Board

- If equipped, check the header board to see that it is secure, free of damage, and strong enough to contain cargo.
- If equipped, the canvas or tarp carrier must be mounted and fastened securely.
- On enclosed trailers, check the front area for signs of damage such as cracks, bulges, or holes.

### Side Of Trailer

#### Landing Gear

- Check that the landing gear is fully raised, has no missing parts, crank handle is secure,

and the support frame is not damaged.

- If power operated, check for air or hydraulic leaks.

#### Doors/Ties/Lifts

- If equipped, check that doors are not damaged. Check that doors open, close, and latch properly from the *outside*.
- Check that ties, straps, chains, and binders are secure.
- If equipped with a cargo lift, look for leaking, damaged or missing parts, and explain how it should be checked for correct operation.
- Lift should be fully retracted and latched securely.

#### Frame

- Look for cracks, broken welds, holes or other damage to the frame, cross members, box, and floor.

#### Tandem Release Arm/Locking Pins

- If equipped, make sure the locking pins are locked in place and release arm is secured.

### Remainder Of Trailer

#### Remainder of Trailer

- Please refer to earlier pages of this handbook for detailed inspection procedures regarding the following components:
  - wheels
  - suspension system
  - brakes
  - doors/ties/lift
  - splash guards

## Coach/Transit Bus

### Passenger Items

#### Passenger Entry/Lift

- Check that entry doors operate smoothly and close securely from the *inside*.



- Check that hand rails are secure and, if equipped, that the step light(s) is working.
- Check that the entry steps are clear, with the treads not loose or worn excessively.
- If equipped with a handicap lift, look for any leaking, damaged, or missing part and explain how it should be checked for correct operation.
- Lift should be fully retracted and latched securely.
- Make sure the lift control interlock(s) functions properly.

### Emergency Exits

- Make sure that all emergency exits are undamaged, operate smoothly, and close securely from the *inside*.
- Check that any emergency exit warning devices are working.

### Passenger Seating

- Look for broken seat frames and check that seat frames are firmly attached to the floor.
- Check that seat cushions are attached securely to the seat frames.

### Entry/Exit

#### Doors/Mirrors

- Check that entry/exit doors are not damaged and operate smoothly from the *outside*. Hinges should be secure with seals intact.
- Make sure that the passenger exit mirrors and all external mirrors and mirror brackets are not damaged and are mounted securely with no loose fittings.

### External Inspection—Coach/Transit Bus

#### Level/Air Leaks

- See that the vehicle is sitting level (front to rear), and if air-equipped, check for audible air leaks from the suspension system.

#### Fuel Tank(s)

- See that fuel tank(s) is secure with no leaks from tank(s) or lines.

#### Compartments

- Check that baggage and all other exterior compartment doors are not damaged, operate properly, and latch securely.

### Remainder Of Coach/Transit Bus

#### Battery/Box

- Wherever located, see that battery(ies) is secure, connections are tight, and cell caps are present.
- Battery connections should not show signs of excessive corrosion.
- Check that battery box and cover or door is not damaged and is secure.

#### Remainder of Vehicle

- Please refer to earlier pages of this handbook for detailed inspection procedures regarding the following components:
  - wheels

**Remember:** The pre-trip vehicle test must be passed before you can proceed to the skills test.

Four basic control skills will be tested using the following exercises off-road or somewhere on the street during the road test:

- Forward stop/Straight line backing
- Alley dock (driver side).

Pass your CDL!



Visit now!

## TYPICAL TRUCK OR COMBINATION VEHICLE INSPECTION GUIDE

- STEP 1: Engine Compartment  
Fluids  
Belts and hoses  
Components (Alternator, etc.)
- STEP 2: Left Side of Cab Area  
General condition  
Left front wheel  
Left front suspension  
Left front brake
- STEP 3: Front of Cab Area  
Condition of front axle  
Condition of steering system  
Condition of windshield  
Light and reflectors
- STEP 4: Right Side of Cab Area  
All items as done on left side of cab area
- STEP 5: Right Saddle Tank Area  
Right fuel tank(s)  
Condition of visible parts
- STEP 6: Trailer Front Area  
Air and electrical connections  
Lights and reflectors
- STEP 7: Right Rear Tractor Wheels Area  
Dual wheels            Suspension  
Tandem axles        Brakes
- STEP 8: Rear of Tractor Area  
Frame and cross members not bent, cracked  
or otherwise damaged or missing  
Lights and reflectors  
Air and electrical lines properly secured to frame,  
not damaged or chafing
- STEP 9: Coupling System Area  
Fifth-wheel (lower)  
Fifth-wheel (upper)  
Sliding fifth-wheel  
Air and electric lines visible from this point
- STEP 10: Right Side of Trailer Area  
Front trailer support (landing gear or dollies)  
Spare tire(s)  
Lights and reflectors  
Frame and body  
Proper placarding
- STEP 11: Right Rear Trailer Wheels Area  
Dual tires    Suspension  
Tandem axles    Brakes
- STEP 12: Rear of Trailer Area  
Lights and reflectors  
Cargo securement
- STEP 13: Left Rear Trailer Wheels Area  
All items as on right side except for air tank draining.
- STEP 14: Left Side of Trailer Area  
All items as on right side and check any traffic side doors.
- STEP 15: Left Saddle Tank Area  
All items as on right saddle tank area.
- STEP 16: In Cab Brake Checks  
Refer to Section 5 for air brake checks.

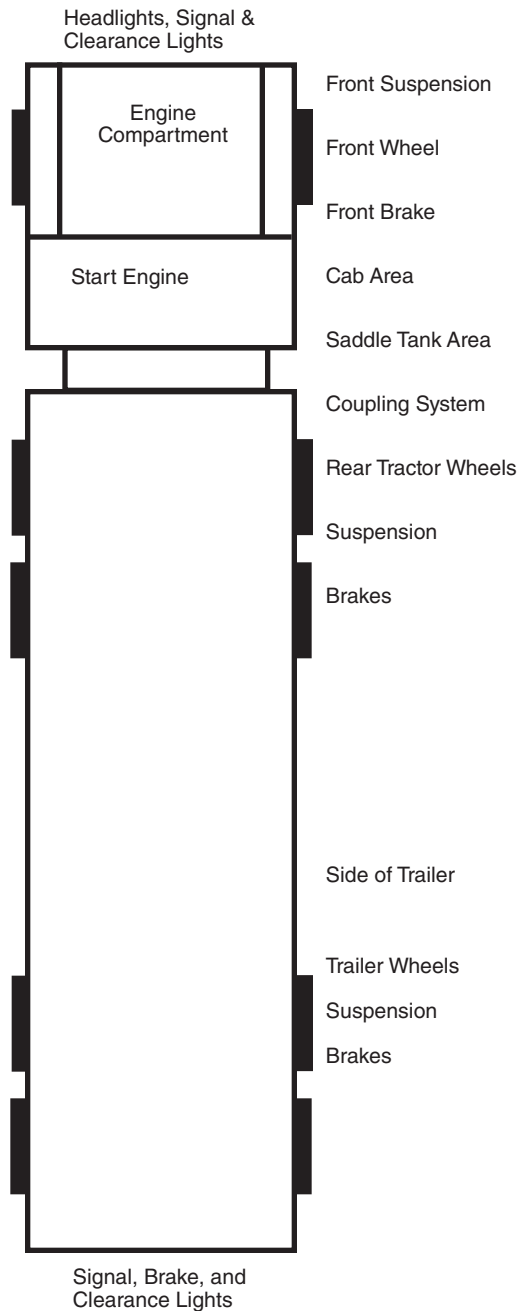

**Need not be done in this exact sequence.**

## TYPICAL PASSENGER TRANSPORT VEHICLE INSPECTION GUIDE

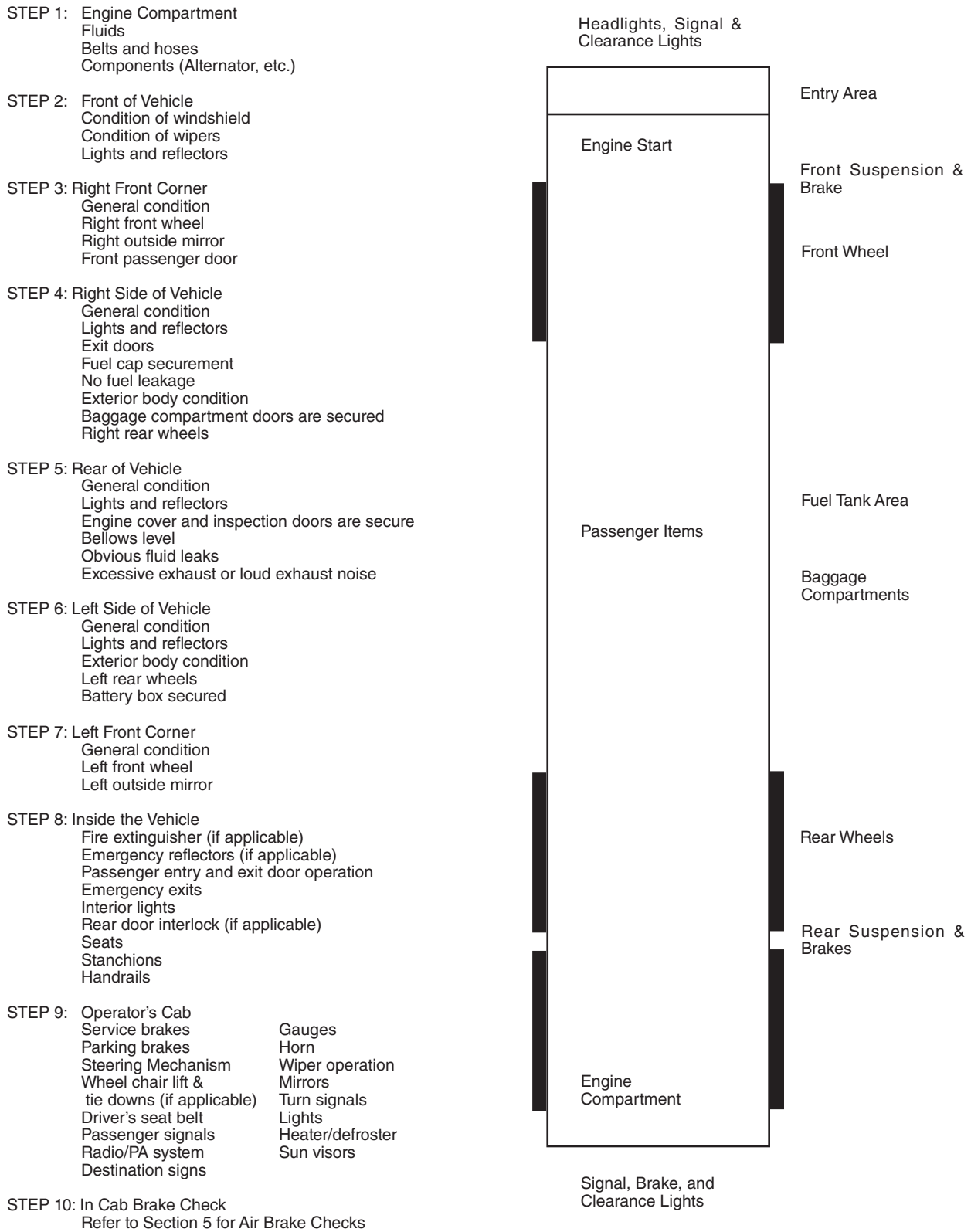

**Need not be done in this exact sequence.**

# Section 11: Skills Test

This section will assist drivers taking the skills tests

- Parallel park (conventional).
- Right turn.

These exercises are shown on the following pages.

## Scoring

The examiner will score the number of times you touch or cross over an exercise boundary line with any portion of your vehicle. Each time you cross over the boundary will count as an error.

In some of the exercises, the examiner will also score the number of times you stop and change direction or pull-up during the exercise. Errors will be explained to you prior to the beginning of each exercise. A failure of any or all skill tests requires a retest fee.

**Remember:** You are allowed a total of three attempts to pass the pre-trip, skills, or driving tests. See page 6.

## Stay In Your Seat

Once you start your skills test, you must stay seated until the test is finished. You may not stop and get out of your seat to check on your progress.

## Exercises

**Forward Stop/Straight Line Backing.** You will be asked to drive forward between two rows of cones and bring your vehicle to a complete stop

as close as you can to the exercise boundary marked by a line or set of cones without going beyond the line or cones. You will be asked to back your vehicle in a straight line between two rows of cones without touching or crossing over the exercise boundaries.

**Alley Dock.** You will be asked to sight-side back your vehicle into an alley, bringing the rear of your vehicles close as possible to the rear of the alley without going beyond the exercise boundary marked by a line or row of cones.

**Parallel Park (Conventional).** You will be asked to park in a parallel parking space that is on your right. You are to drive past the parking space and back into it bringing the rear of your vehicle as close as possible to the rear of the space without crossing side or rear boundaries marked by cones. You are to try to get your vehicle (or trailer, if combination vehicle) completely into the space.

**Right Turn.** You will be asked to drive forward and make a right turn around a cone or marker. The rear wheel should come as close to the cone or marker as possible without touching it.

You will drive over a test route that has a variety of traffic situations. At all times during the test, you must drive in a safe and responsible manner.

### Forward Stop/Straight Line Backing

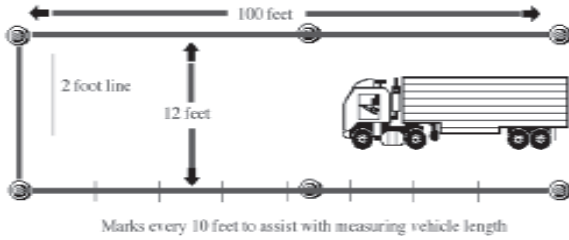

You will drive forward between two rows of cones and bring your vehicle to a complete stop as close as you can to the exercise boundary marked by a line or set of cones without going beyond the line or cones.

Then, you will back your vehicle in a straight line between two rows of cones without touching or crossing over the exercise boundaries.

### Parallel Park

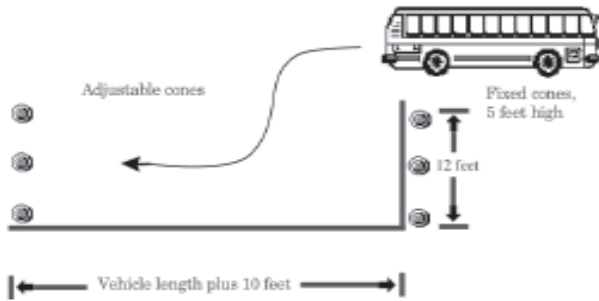

You will parallel park your vehicle or trailer (only if combination vehicle) in a designated area without striking any boundaries. You will be required to position the vehicle or trailer inside the parking area.

**NOTE:** Combination vehicle park (trailer only) = trailer length + 10 feet. Truck or bus = whole vehicle length + 10 feet.

### Alley Dock

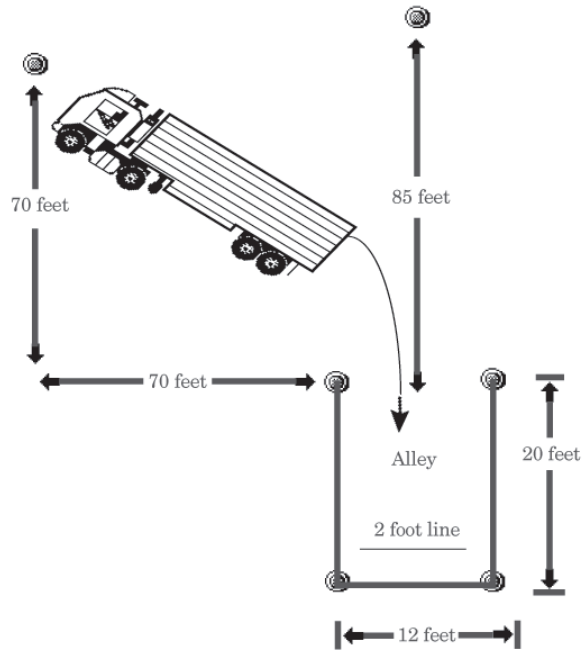

You will dock a single vehicle or a trailer (if it is a combination) from about a 90° angle without touching any of the cones or stanchions while staying within the boundaries.

### Right Turn

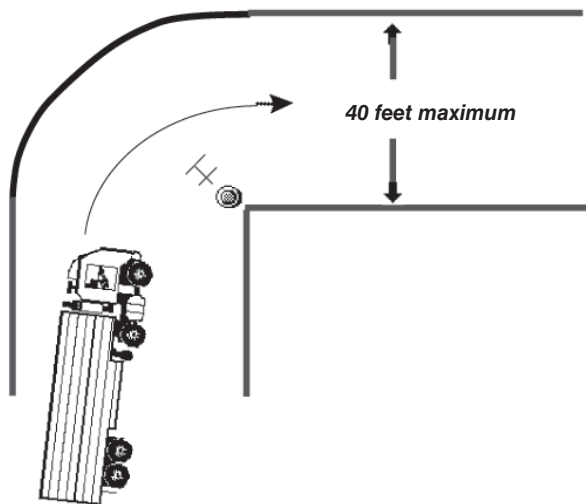

You will make a right turn around a corner, with the back axles of the vehicle as close to the designated cone as possible, without striking it.

## Section 12: Driving Test

This section will assist drivers taking the driving test

During the driving test, the examiner will be scoring you on specific driving maneuvers as well as on your general driving behavior. You will follow the directions of the examiner. Directions will be given to you so you will have plenty of time to do what the examiner has asked. You will not be asked to drive in an unsafe manner.

If your test route does not have certain traffic situations, you may be asked to simulate a traffic situation. You will do this by telling the examiner what you are or would be doing if you were in that traffic situation. A failure of the driving test will require a retest fee.

**Remember:** You are allowed a total of three attempts to pass the pre-trip, skills, or driving tests. See page 6.

### How Will You Be Tested?

**You have been asked to make a turn:**

- Check traffic in all directions.
- Use turn signals and safely get into the lane needed for the turn.

#### Turns

**As you approach the turn:**

- Use turn signals to warn others of your turn.
- Slow down smoothly, change gears as needed to keep power, but do not coast unsafely. Unsafe coasting occurs when your vehicle is out of gear for more than the length of your vehicle.

**If you must stop before making the turn:**

- Come to a smooth stop without skidding.
- Come to a complete stop behind the stop line, crosswalk, or stop sign.
- If stopping behind another vehicle, stop where you can see the rear tires on the vehicle ahead of you (safe gap).

- Keep the front wheels aimed straight ahead.

**When ready to turn:**

- Check traffic in all directions.
- Keep both hands on the steering wheel during the turn.
- Do not change gears during the turn.
- Keep checking your mirror to make sure the vehicle does not hit anything on the inside of the turn.
- Vehicle should not move into oncoming traffic.
- Vehicle should finish turn in correct lane.

**After turn:**

- Make sure turn signal is off.
- Get up to speed of traffic, use turn signal, and move into the far right lane when safe to do so (if not already there).

#### Intersections

**As you approach an intersection:**

- Check traffic thoroughly in all directions.
- Decelerate gently.
- Brake smoothly and, if necessary, change gears.
- If necessary, come to a complete stop behind any stop signs, signals, sidewalks, or stop lines maintaining a safe gap behind any vehicle in front of you.
- Your vehicle must not roll forward or backward.

**When driving through an intersection:**

- Check traffic thoroughly in all directions.
- Decelerate and yield to any pedestrians and traffic in the intersection.
- Do not change lanes or shift gears while proceeding through the intersection.
- Keep your hands on the wheel.

**Once through the intersection:**

- Continue checking traffic.
- Accelerate smoothly and change gears as necessary.

**Urban/Rural Normal Driving**

During this part of the test, you are expected to make regular traffic checks and maintain a safe following distance. Your vehicle should be centered in the proper lane and you should keep up with the flow of traffic but not exceed the posted speed limit.

**Urban/Rural Lane Changes**

During the multiple lane portion of the urban or rural sections, you will be asked to change lanes to the left, and then back to the right. You should make the necessary traffic checks first, then use proper signals and smoothly change lanes when it is safe to do so.

**Freeway Driving****Before entering the freeway:**

- Check traffic.
- Use proper signals.
- Merge smoothly into the proper traffic lane.

**Once on the freeway:**

- Maintain proper lane position, distance, and speed.
- Continue to check traffic thoroughly in all directions.

**You will be instructed to change lanes:**

- You must make necessary traffic checks.
- Use proper signals.
- Change lanes smoothly when it is safe to do so.

**When exiting the freeway:**

- Make necessary traffic checks.
- Use proper signals.
- Decelerate smoothly in the exit lane.
- Once on the exit ramp, you must continue to decelerate within the lane markings and maintain adequate following distance.

**Stop/Start**

For this maneuver, you will be asked to pull your vehicle over to the side of the road and stop as if you were going to get out and check something on your vehicle. You must check traffic thoroughly in all directions and move to the far right lane or shoulder of the road.

**As you prepare for the stop:**

- Check traffic.
- Turn on your right turn signal.
- Decelerate smoothly, brake evenly, change gears as necessary.
- Bring your vehicle to a full stop without coasting.

**Once stopped:**

- Vehicle must be parallel to the curb or shoulder of the road and safely out of the traffic flow.
- Vehicle should not be blocking driveways, fire hydrants, intersections, signs, etc.
- Cancel your turn signal.
- Activate 4-way emergency flashers.
- Apply the parking brake.
- Move the gear shift to neutral or park.
- Take your feet off the brake and clutch pedals.

**When instructed to resume:**

- Check traffic and your mirrors thoroughly in all directions.
- Turn off 4-way flashers.
- Turn on left turn signal.
- When traffic permits, you should release the parking brake and pull straight ahead.
- Do not turn the wheel before your vehicle moves.
- Check traffic from all directions, especially to the left.
- Steer and accelerate smoothly into the proper lane when safe to do so.
- Once your vehicle is back into the flow of traffic, cancel your left turn signal.



## Curve

### When approaching a curve:

- Check traffic thoroughly in all directions.
- Before entering the curve, reduce speed so further braking or shifting is not required in the curve.
- Keep vehicle in the lane.
- Continue checking traffic in all directions.

## Upgrade

### As you approach the upgrade:

- Select the proper gear to maintain speed and not lug the engine.
- Check traffic thoroughly in all directions and move to the far right lane.

## Simulated Downgrade

### Explain how to go down a steep grade:

- Select a flat section of road about a quarter mile long, with little or no traffic.
- Demonstrate and explain the actions taken while driving down a steep grade.

## Downgrade

### Before starting down the grade:

- Downshift as needed to help control engine speed and test brakes by gently applying the foot brake to ensure they are functioning properly. As your vehicle moves down the grade, continue checking traffic in all directions and stay in the far right lane. Increase following distance and observe the following downhill braking procedures:
  - Select a “safe” speed, one that is not too fast for the weight of the vehicle, length, and steepness of the grade, weather, and road conditions.
  - Once a safe speed has been reached, apply the brake hard enough to feel a definite slowdown.
  - When speed has been reduced to 5 m.p.h.

below the safe speed, release the brakes.

- Once speed has increased to the safe speed, repeat the procedure.

When operating any commercial vehicle, do not ride the clutch, race the engine, change gears, or coast while driving down the grade. At the bottom of the grade, be sure to cancel your 4-way flashers.

Not all test routes will contain an area of sufficient grade to test your skill adequately. Therefore, you may be asked to simulate (verbally) driving up and down a steep hill. You must be familiar with the upgrade/downgrade procedures so that you can explain and/or demonstrate them to the examiner at any time during the driving test.

## Railroad Crossing

### Before reaching the crossing, all commercial drivers should:

- Decelerate, brake smoothly, and shift gears as necessary.
- Look and listen for the presence of trains.
- Check traffic in all directions.

Do not stop, change gears, pass another vehicle, or change lanes while any part of your vehicle is in the crossing.

### If you are driving a bus, a school bus, or a vehicle displaying placards, you should be prepared to observe the following procedures at every railroad crossing (unless the crossing is exempt):

- As the vehicle approaches a railroad crossing, activate the 4-way flashers.
- Stop the vehicle within 50 feet but not less than 15 feet from the nearest rail.
- Listen and look in both directions along the track for an approaching train and for signals indicating the approach of a train. If operating a bus, you may also be required to open the window and door prior to crossing tracks.

- Keep hands on the steering wheel as the vehicle crosses the tracks.
- Do not stop, change gears, or change lanes while any part of your vehicle is proceeding across the tracks.
- 4-way flashers should be turned off after the vehicle crosses the tracks.

Not all driving tests will have a railroad crossing. You may be asked to explain and demonstrate the proper railroad crossing procedures to the examiner at a simulated location.

### Bridge/Overpass/Sign

After driving under an overpass, you may be asked to tell the examiner what the posted clearance or height was. After going over a bridge, you may be asked to tell the examiner what the posted weight limit was. If your test route does not have an overpass or bridge, you may be asked about another traffic sign. When asked, be prepared to identify and explain to the examiner any traffic sign which may appear on the route.

### During the driving test you must:

- Wear your safety belt.
- Obey all traffic signs, signals, and laws.
- Complete the test without an accident or moving violation.

You will be scored on your overall performance in the following general driving behavior categories:

### Clutch Usage (for manual transmission)

- Always use clutch to shift.
- Double-clutch if vehicle is equipped with non-synchronized transmission.
- Do not rev or lug the engine.
- Do not ride clutch to control speed, coast with the clutch depressed, or “pop” the clutch.

### Gear Usage (for manual transmission)

- Do not grind or clash gears.
- Select gear that does not rev or lug engine.
- Do not shift in turns and intersections.

### Brake Usage

- Do not ride or pump brake.
- Do not brake harshly. Brake smoothly using steady pressure.

### Lane Usage

- Do not drive the vehicle over curbs, sidewalks, or lane markings.
- Stop behind stop lines, crosswalks, or stop signs.
- Complete turns in the proper lane on multiple lane roads.
- Finish right turns in the right lane.
- Move to or remain in the far right lane unless the lane is blocked.

Figure 4-1

⚡ - Official traffic control signal

⊗ - Railroad crossing warning device

#### EXEMPT CROSSINGS

#### NOT EXEMPT

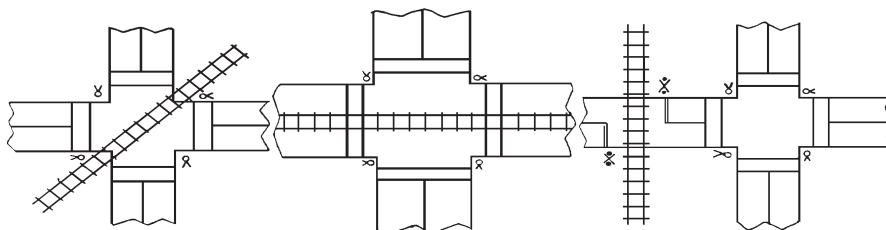

# Glossary

**Bulk packaging**—a packaging, including a transport vehicle or freight container in which hazardous materials are loaded with no intermediate form of containment, with a capacity greater than:

- 450 L (119 gallons) for a liquid,
- 450 L (119 gallons) and a net mass greater than 400 kg (882 lbs.) for a solid, or
- water capacity greater than 454 kg (1000 lbs.) for a gas

**California Hazardous Waste Manifest**—shipping paper which must accompany all shipments of hazardous waste.

**CalTrans**—California Department of Transportation

**Carboy**—a bottle or rectangular container that holds from 5 to 15 gallons of liquid. Carboys are made of glass, plastic, or metal and are often cushioned in a wooden box.

**Cargo tank**—any bulk liquid or compressed gas packaging, whether or not permanently attached to any motor vehicle, which by reason of its size, construction, or attachment to a motor vehicle, is loaded or unloaded without being removed from the motor vehicle. Any packaging fabricated under specifications for cylinders is not a cargo tank.

**Carrier**—a person engaged in the transportation of passengers or property by land or water (as a common, contract, or private carrier) or by civil aircraft.

**CCR**—*California Code of Regulations*—Title 13 and Title 22

**CFR**—*Code of Federal Regulations*—Title 49

**CHP**—California Highway Patrol

**Compressed Gas**—any gaseous material, or liquefied gas, kept in a container under pressure. (See more specific Class 2 definitions in 49 CFR 173.115.)

**Consignee**—the business or person to whom a shipment is delivered.

**Cryogenic liquid**—a refrigerated liquefied gas having a boiling point colder than -130°F at 14.7 p.s.i.a.

**Cylinder**—a pressure vessel designed for pressures higher than 40 p.s.i.a. and having a circular cross section. It does not include a portable or cargo tank.

**DMV**—Department of Motor Vehicles

**DOT**—Department of Transportation (Federal)

**DTSC**—Department of Toxic Substance Control

**EPA**—U. S. Environmental Protection Agency

**FAA**—Federal Aviation Administration

**FHWA**—Federal Highway Administration

**FMCSA**—Federal Motor Carrier Safety Administration

**Freight container**—a reusable container designed and constructed to permit being lifted with its contents intact and intended primarily for containment of packages (in unit form) during transportation.

**Gross Weight**—the weight of the packaging plus the weight of its contents.

**Hazardous material**—any material that poses an unreasonable risk to health, safety, and property during transportation. These materials are named by the DOT in the Hazardous Materials Table.

**Infectious substances or etiologic agents**—a living microorganism, or its toxin, which causes or may cause human or animal disease.

**Limited quantity**—when specified as such in a section applicable to a particular material, it means the maximum amount with specific placarding, labeling, and packaging exceptions.

**Marking**—applying the descriptive name(s), identification numbers, instructions, cautions, weight(s), or specification marks required to be placed on the outside of hazardous materials packages and/or their transport vehicle(s).

**Mixture**—a material containing more than one chemical compound or element.

**Name of contents**—the proper shipping name as specified in the Hazardous Materials Table.

**n.o.s.**—not otherwise specified

**Outage**—the amount by which a packaging falls short of being liquid full, usually expressed in percent by volume. The amount of outage required for liquids in cargo tanks depends on how much the material will expand with temperature change during transit. Different materials expand at different rates. Enough outage must be allowed so that the tank will still not be full at 130°F.

**Overpack**—an enclosure used by a single shipper to provide protection or convenience in handling of a package or to combine two or more packages. “Overpack” does not include a transport vehicle or a freight container.

**Portable tank**—any bulk packaging (except a cylinder having a 1000 lbs. or less water capacity) designed primarily to be loaded in, on, or temporarily attached to, a transport vehicle. A portable tank is equipped with skids, mounting, or accessories to facilitate handling of the tank by mechanical means.

**Proper shipping name**—the name of the hazardous material shown in Roman print (not italics) in the Hazardous Materials Table.

**p.s.i.**—Pounds per square inch.

**p.s.i.a.**—Pounds per square inch absolute.

**PUC**—Public Utilities Commission

**Registered Hazardous Waste Transporter**—person registered by DTSC who engages in the offsite transportation of hazardous waste by air, rail, highway, or water.

**Reportable quantity (RQ)**—the quantity (per single package) which equals or exceeds the quantity specified in column 3 of the List of Hazardous Substances and Reportable Quantities. Reportable quantities are treated as hazardous materials and have specific spill reporting requirements.

**Shipper’s certification**—a statement on a shipping paper, signed by the shipper, saying he or she prepared the shipment properly according to law.

“This is to certify that the above named materials are properly classified, described, packaged, marked and labeled and are in proper condition for transportation according to the applicable regulations of the Department of Transportation.”

**or**

I hereby declare that the contents of this consignment are fully and accurately described above by the proper shipping name and are classified, packaged, marked and labeled/placarded, and are in all respects in proper condition for transport according to applicable international and national governmental regulations.”

**Shipping paper**—a shipping order, bill of lading, manifest or other shipping document serving a similar purpose and containing the information required by the regulations.

**Tank vehicle**—any commercial motor vehicle with any size fixed tank(s) (except tanks necessary for vehicle operation such as: air, gas, and oil) or portable tanks of 1,000 gallons or more capacity.

Also includes any fixed tank in excess of 119 gallons mounted on any vehicle or vehicle combination which requires a CDL or placards.

To transport hazardous materials or wastes, a Tank Vehicle Endorsement and a HAZMAT endorsement is required for a fixed tank(s) regardless of the weight of the vehicle or the size of the tank. If the tank is portable and is under 1,000 gallons, only the HAZMAT endorsement is required.

**Technical name**—a recognized chemical name or microbiological name currently used in scientific and technical handbooks, journals, and texts.

**Title 13**—*California Code of Regulations*—Motor Vehicles.

**Title 22**—*California Code of Regulations*—Environmental Health Standards for the Management of Hazardous Waste.

**Transport vehicle**—a cargo carrying vehicle such as an automobile, van, tractor, truck, semitrailer, tank car, or rail car used for the transportation of cargo by any mode. Each cargo carrying body (trailer, rail car, etc.) is a separate transport vehicle.

**VC §**—*California Vehicle Code Section*.

**Water reactive material**—any material (including sludges and pastes) which when mixed with water, is likely to ignite or give off flammable or toxic gases in dangerous quantities. Water reactive material is required to be labeled DANGEROUS WHEN WET.

## To Purchase Reference Materials

A *California Vehicle Code* book may be viewed online at [www.dmv.ca.gov](http://www.dmv.ca.gov) or be purchased at any DMV office.

California Regulations relating to commercial vehicles are contained in Title 13 of the *California Code of Regulations* (CCR).

Title 13, CCR, may be purchased from:

Thomson-West Group  
PO Box 95767  
Chicago, IL 60694-5767  
Telephone Number 1-800-866-3600

[www.barclaysccr.com](http://www.barclaysccr.com)

Copies of the *Code of Federal Regulations*, Title 49, or Title 22, CCR, Division 4.5 may be purchased from:

Superintendent of Documents  
U. S. Government Printing Office  
Washington, D. C. 20402  
Telephone Number (202) 512-1800  
7:30 AM to 4:30 PM EST

Fax Number (202) 512-2250

[www.access.gpo.gov](http://www.access.gpo.gov)

## Disclaimer

When using this handbook, please remember that it is only a summary of the laws and regulations. DMV, law enforcement, and courts follow the full and exact language of the law contained in the *California Vehicle Code*. You may view the most current *California Vehicle Code* on our website at [dmv.ca.gov](http://dmv.ca.gov) or purchase a copy at any DMV office.

## Where To Write

Questions or comments regarding this handbook may be addressed to:

Department of Motor Vehicles  
Customer Communications Unit  
MS H165  
PO Box 932345  
Sacramento, CA 94232-3450

Pass your CDL!



Visit now!

Pass your CDL!



Visit now!

Pass your CDL!



Visit now!